

Plastic Modular Belt

Series **uni Flex ONE** Type **15% Open (Radius 1.6)**

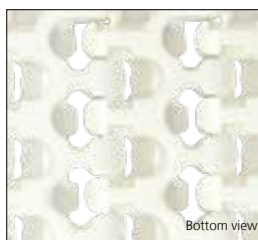
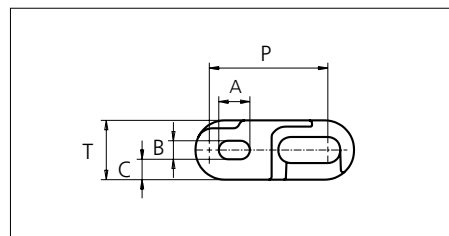
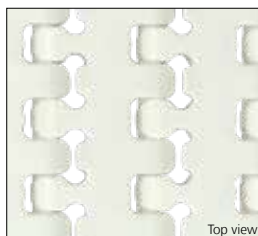

Sideflexing belt
 Nominal pitch: 38.1 mm (1.50 in)
 Surface type: Flat
 Surface opening: 15%
 Backflex radius: 50.0 mm (1.97 in)
 Min. inside radius R1.6 x belt width

Belt material & color	POM-SX W B **
----------------------------------	-----------------------------

	mm	in		mm	in
P (Nominal)	38.1	1.50	C	6.6	0.26
A	10.0	0.39	T	19.1	0.75
B	5.9	0.23	-	-	-

*uni-chains recommends this travel direction. However travel in both directions is possible.

**Please note that uni Flex ONE in POM-SX blue is not according to the standard color quality for blue. Small variations may occur.

Belt width			Permissible tensile force Belt material				Belt weight Belt material		*Recommended No. drive sprocket per shaft	Number of wear strips (Min no.)	
			POM-SX				POM-SX			Carry (pcs)	Return (pcs)
			Straight sections		Curve sections		kg/m	lb/ft			
Size	mm	in	N	lbf	N	lbf					
K750	190.5	7.50	2400	540	2000	450	2.6	1.75	2	2	2
K1200	304.8	12.00	4000	899	3400	764	4.1	2.76	3	2	2
K1400**	355.6	14.00	5600	1259	3400	764	4.7	3.16	3	2	2
K1500	381.0	15.00	6400	1439	3500	787	5.0	3.36	3	2	2
K1800	457.2	18.00	8200	1843	3600	809	6.2	4.17	5	2	2
K2400	609.6	24.00	12000	2698	3800	854	8.0	5.38	5	2	2

General belt tolerance is +0/-0.4% at 23°C/73°F.

*Max. Load per Drive Sprocket. Belt material: POM-SX 2500 N (562 lbf)

**Flex ONE-K1400 is not available with any type of edge accessories

STANDARD

SIDE FLEXING

PITCH 38.1 MM/1.50 IN

Edge Accessories

uni Flex ONE EO Tab (Exchangeable Outer Tab)

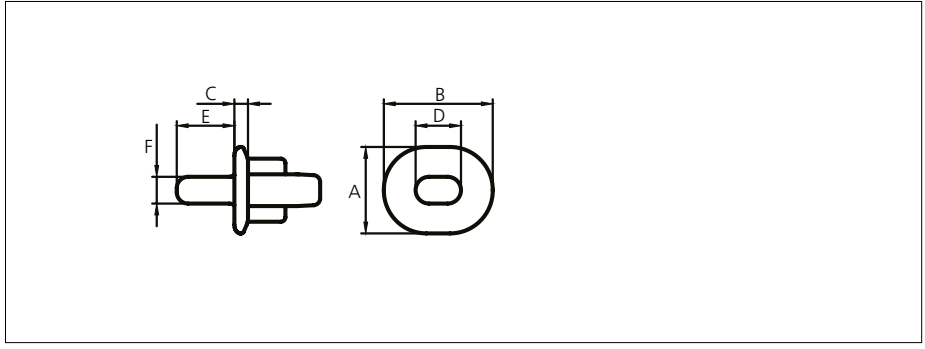

Type	EO-Tab material & color	A		B		C		D		E		F	
		mm	in	mm	in	mm	in	mm	in	mm	in	mm	in
Exchangeable Outer Tab	POM DK O	19.1	0.75	24.0	0.94	3.0	0.12	10.0	0.39	12.7	0.50	5.9	0.23

When using the EO Tab in both sides, the width of the belt will be the same as the uni Flex ONE 15% open. See page 1.

Edge Accessories

uni Flex ONE EOO Tab (Exchangeable Outer Offset Tab)

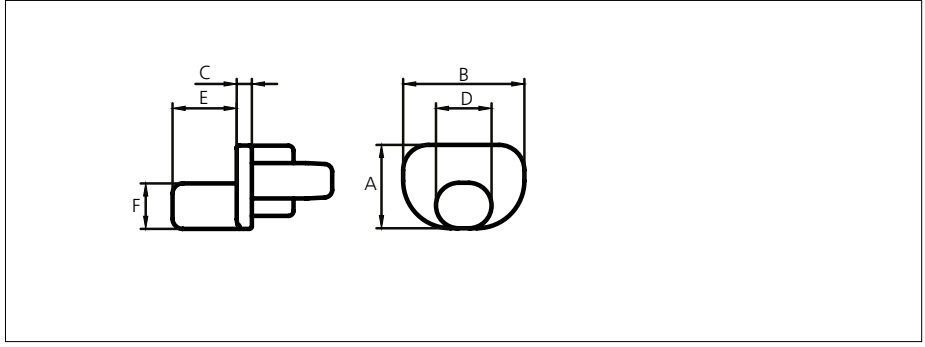

Type	EOO-Tab material & color	A		B		C		D		E		F	
		mm	in	mm	in	mm	in	mm	in	mm	in	mm	in
Exchangeable Outer Offset Tab	POM DK O	16.5	0.65	24.0	0.94	3.0	0.12	11.0	0.43	12.7	0.50	9.0	0.35

When using the EOO Tab in both sides, the width of the belt will be the same as the uni Flex ONE 15% open. See page 1.

Edge Accessories

uni Flex ONE EC Tab (Exchangeable C-Shape Tab)

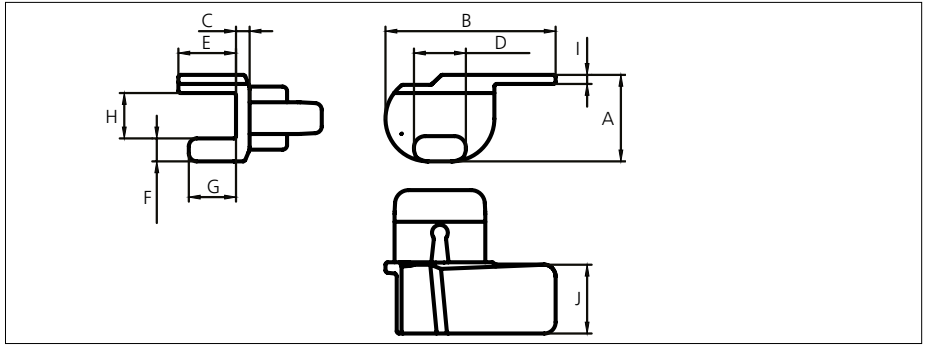
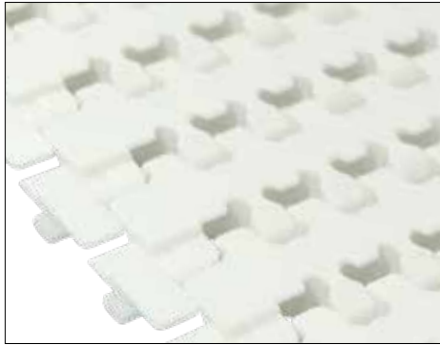

Type	EC-Tab material & color	A		B		C		D		E	
		mm	in	mm	in	mm	in	mm	in	mm	in
Exchangeable C-Shape Tab	POM-SX W B	19.1	0.75	37.5	1.48	3.0	0.12	10.5	0.41	12.7	0.50
		F		G		H		I		J	
		mm	in	mm	in	mm	in	mm	in	mm	in
		5.0	0.20	10.4	0.41	10.0	0.39	2.0	0.08	15.2	0.60

When using the EC Tab, the width of both sides of the belt width will increase 1.00 in.

Edge Accessories

uni Flex ONE EW (Exchangeable Wearpart)

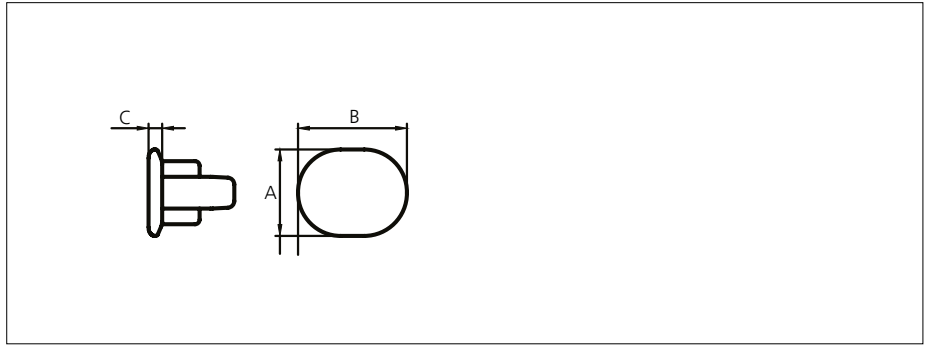

Type	EW Wearpart material & color	A		B		C	
		mm	in	mm	in	mm	in
Exchangeable Wearpart	POM DK O	19.1	0.75	24.0	0.94	3.0	0.12

When using the EW in both sides, the width of the belt will be the same as the uni Flex ONE 15% open. See page 1.

Edge Accessories

uni Flex ONE EWC (Exchangeable Wearpart Closed)

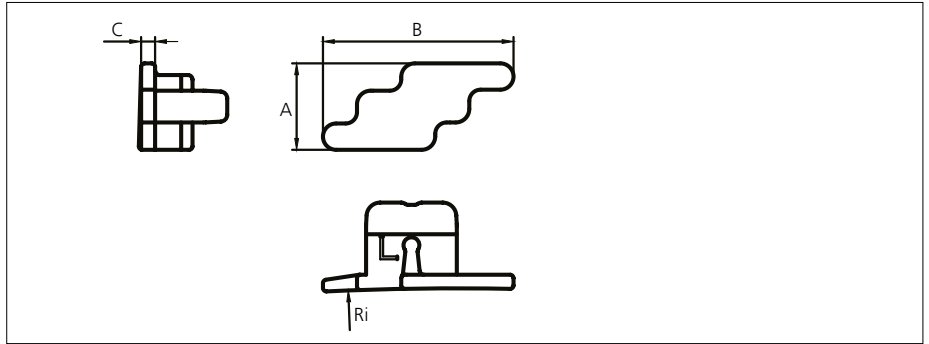

Type	EWC Wearpart material & color	A		B		C		Ri	
		mm	in	mm	in	mm	in	mm	in
Exchangeable Wearpart Closed	K750: POM DK Y							308.8	12.00
	K1200, K1500, K1800: POM DK O	19.1	0.75	24.0	0.94	3.0	0.12	609.6	24.00
	K2400: POM DK B							975.4	38.40

When using the EWC in both sides, the width of the belt will be the same as the uni Flex ONE 15% open. See page 1.

Edge Accessories

uni Flex ONE ER (Exchangeable Roller)

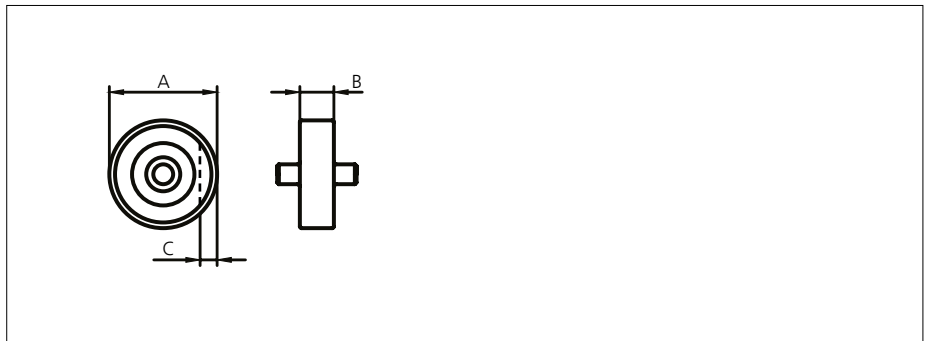

Type	ER material	A		B		C*	
		mm	in	mm	in	mm	in
Exchangeable Roller	SS	19.1	0.75	6.0	0.24	3.0	0.12

When using the ER in both sides, the width of the belt will be the same as the uni Flex ONE 15% open. See page 1.

* Distance from edge of belt to outside ball bearing.

Other accessories

Flight

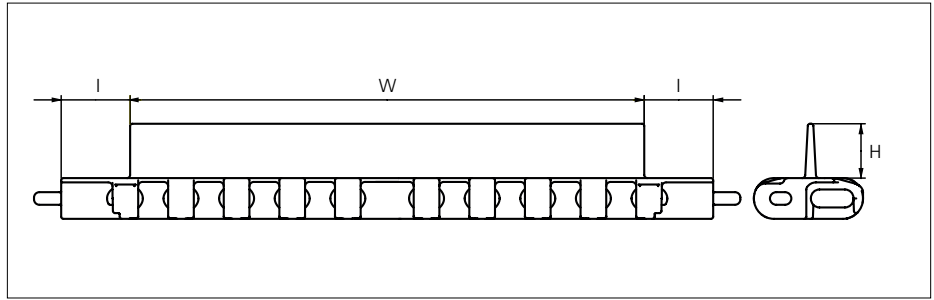
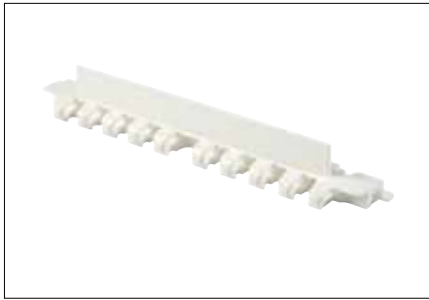

Type	Standard belt material & color	Height (H)		Indent (I)		Link size	Width (W)	
		mm	in	mm	in		mm	in
Flight	POM-SX W B *	25.4	1.00	32.2	1.27	K1200	254.0	10.00

* Please note that uni Flex ONE in POM-SX blue is not according to the standard color quality for blue. Small variations may occur. Non Standard material and color: See uni Material and Color Overview.

Rubber Top

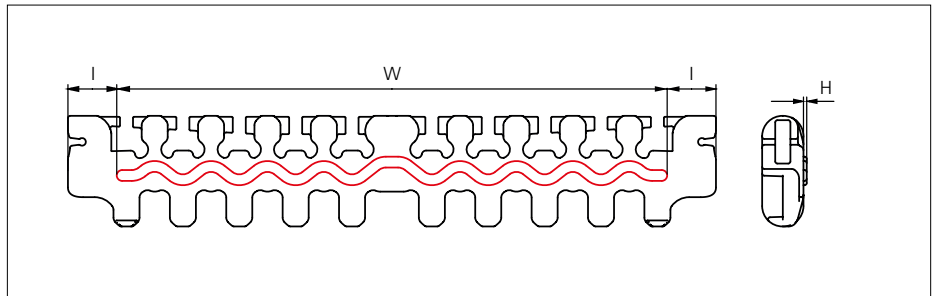
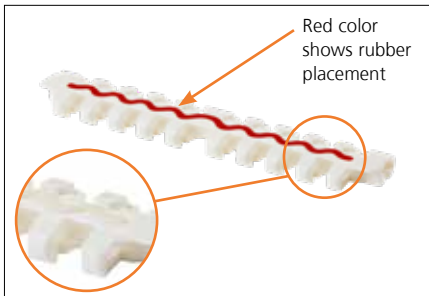

Type	Standard belt material & color	Height (H)		Indent (I)		Link size	Width (W)	
		mm	in	mm	in		mm	in
Snake	POM-SX W B * + Rubber 01 N	1.5	0.06	22.5	0.86	K750	140.0	5.51
						K1200	259.8	10.23

* Please note that uni Flex ONE in POM-SX blue is not according to the standard color quality for blue. Small variations may occur. Non Standard material and color: See uni Material and Color Overview.

Other accessories

Clip On Flight

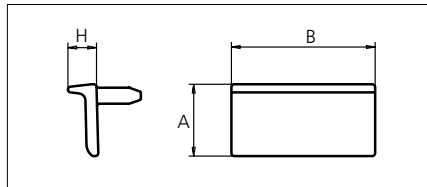

Clip On Rubber Flat

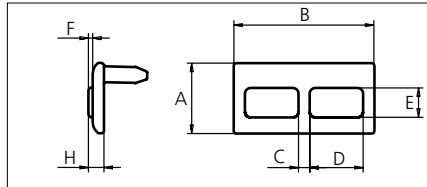

Clip On Rubber Cone

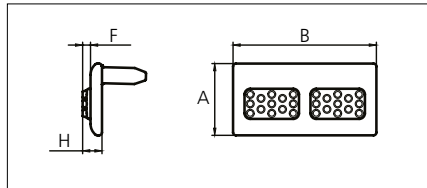

	mm	in
A	25.0	0.98
B	50.0	1.97
C	4.0	0.16
D	19.0	0.75
E	10.5	0.41
F	2.8	0.11
H	6.8	0.27

Type	Height (H)		Standard materials & colors
	mm	in	
Clip On Flight	10.0	0.39	POM-D O
Clip On Rubber Flat	5.5	0.22	POM-D O + Rubber 01 K
Clip On Rubber Cone	6.8	0.27	POM-D O + Rubber 01 K

Design Guidelines

uni Flex ONE O and EO

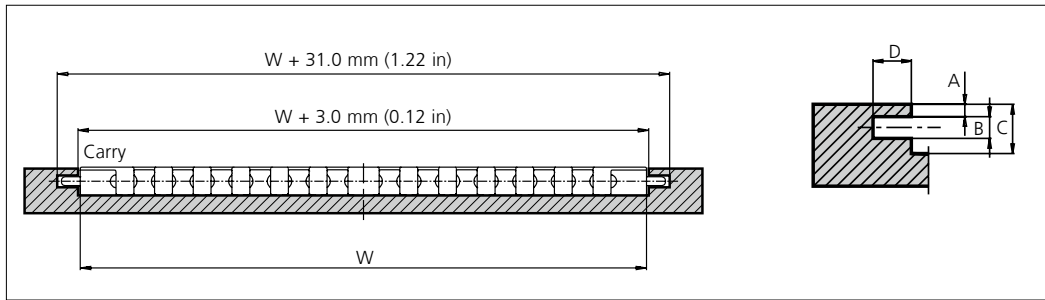

	mm	in
A	4.5	0.18
B	8.0	0.31
C	18.0	0.71
D	14.0	0.55

uni Flex ONE O

Using the uni Flex ONE with O-Tab and a slotted wearstrip, the O-Tab will allow the transported products to be wider than the belt. O-Tabs are molded into the belt to ensure cleanability and are preferred for direct food contact.

uni Flex ONE EO (Exchangeable O-Tab)

Exchangeable O-Tab system is made of heat and wear resistant material to improve performance between the belt edge and the wearstrip. Using a slotted wearstrip the exchangeable O-Tab will track the belt and allow the transported products to be wider than the belt. Resists high curve load at increased speed.

Design Guidelines

uni Flex ONE O and EO

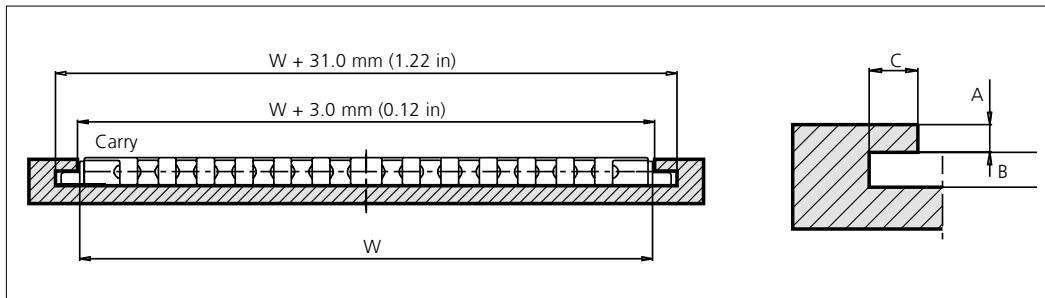

	mm	in
A	8.0	0.31
B	10.0	0.39
C	14.0	0.55

uni Flex ONE EOO (Exchangeable Offset O-Tab)

Exchangeable O-Tab system is made of heat and wear resistant material to improve performance between the belt edge and the wearstrip. Using a slotted wearstrip the exchangeable O-Tab will track the belt and allow the transported products to be wider than the belt. Resists high curve load at increased speed.

Design Guidelines

uni Flex ONE EC

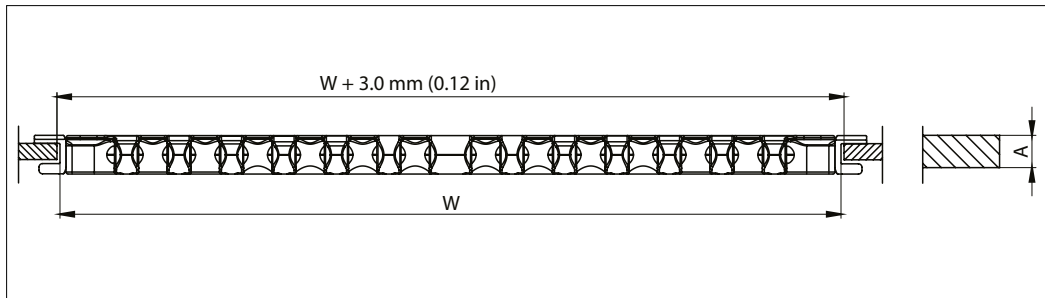

	mm	in
A	8.0	0.31

Design Guidelines

uni Flex ONE EW and ER

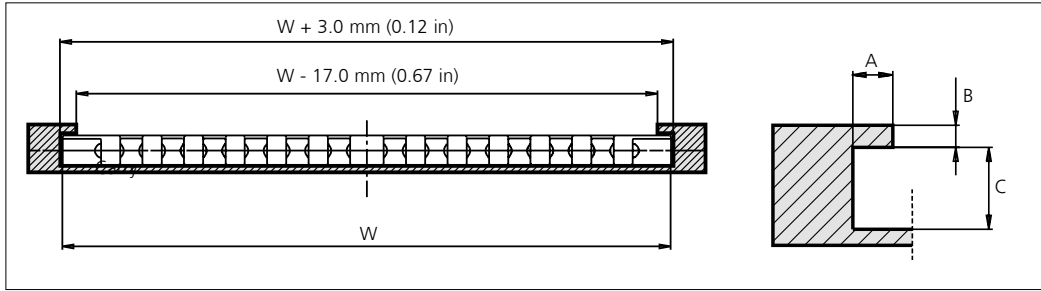

	mm	in
A	10.0	1.39
B	5.5	0.22
C	20.5	0.81

uni Flex ONE EW (Exchangeable Wearpart)

Exchangeable Wearpart system is made of heat and wear resistant material to improve performance between the belt edge and the wearstrip. This Wearpart can easily be replaced. Resists high curve load at increased speed.

uni Flex ONE ER (Exchangeable Edge Roller)

uni Flex ONE with Exchangeable Edge Rollers reduces friction in curves to a minimum making it very suitable for applications with many curves e.g. static spirals (non rotating drum) or high speed sideflexing conveyors.

Design Guidelines

uni Flex ONE EWC

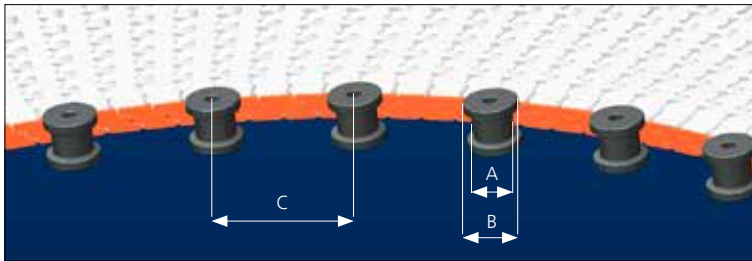
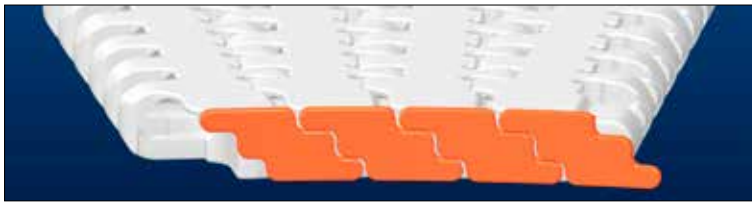

	mm	in
A	min $\varnothing 30$	min $\varnothing 1\frac{1}{4}$
B	A + min 12	A + min $\frac{1}{2}$
C	100-150	4-6

Overall Design Guidelines

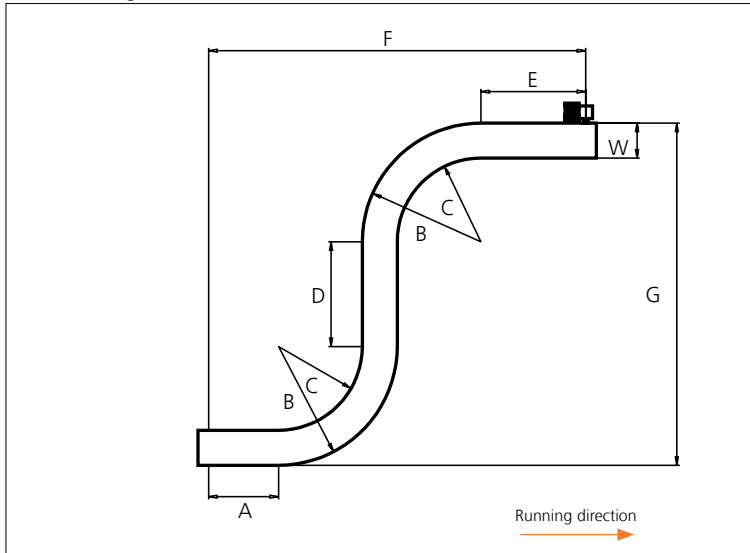

For min. conveyor dimensions please refer to sketch and diagram.

	Layout Guidelines
A	min. 1.0 x W
B	min. 2.6 x W
C	min. 1.6 x W
D	min. 2.0 x W
E	min. 1.0 x W
F	min. 6.2 x W
G	min. 7.2 x W

Sprocket

No. of teeth	Bore size								Overall diameter		Pitch diameter		Hub diameter		Dimension A		Dimension B		Single row/One way	Molded	PA6 LG
	Pilot Bore	in		1.00		1.18		1.25													
	mm	25.0	25.4	30.0	31.8	38.1	40.0	mm	in	mm	in	mm	in	mm	in	mm	in				
Z08	✓	■	●	●	●	●	●	101	3.98	99.6	3.93	60.0	2.36	36.5	1.44	59.0	2.32	✓	✓		
Z09	✓		●	●	●		●	113.7	4.48	111.4	4.39	70.0	2.76	42.8	1.69	64.9	2.56	✓	✓		
Z09							■	113.7	4.48	111.4	4.39	74.0	2.91	42.8	1.69	64.9	2.56	✓	✓		
Z11	✓		●	●	●			138.8	5.46	135.2	5.32	70.0	2.76	55.4	2.18	76.9	3.03	✓	✓		
Z11							■	138.8	5.46	135.2	5.32	74.0	2.91	55.4	2.18	76.9	3.03	✓	✓		
Z12	✓			●	●	●	●	151.2	5.95	147.2	5.80	70.0	2.76	61.6	2.43	82.9	3.26	✓	✓		
Z12							■	151.2	5.95	147.2	5.80	74.0	2.91	61.6	2.43	82.9	3.26	✓	✓		
Z13	✓			●	●	●	●	163.6	6.44	159.2	6.27	70.0	2.76	67.8	2.67	88.9	3.50	✓	✓		
Z13							■	163.6	6.44	159.2	6.27	74.0	2.91	67.8	2.67	88.9	3.50	✓	✓		
Z16	✓			●	●	●	●	200.5	7.89	195.3	7.69	70.0	2.76	86.3	3.40	107.0	4.21	✓	✓		
Z16							■	200.5	7.89	195.3	7.69	74.0	2.91	86.3	3.40	107.0	4.21	✓	✓		

■ Molded sprocket

● Molded sprocket

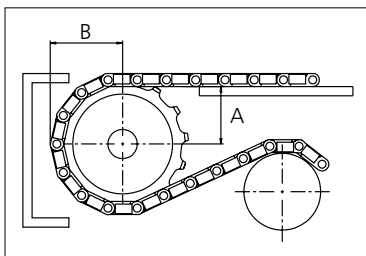

Non standard material and color: See uni Material and Color Overview.

Other sprocket sizes are available upon request
 Other bore sizes are available upon request
 uni Retainer Rings: See uni Retainer Ring data sheet
 Width of tooth = 9.0 mm (0.35 in)
 Width of sprocket = 39.0 mm (1.54 in)

Max. load per sprocket shown does not take bore size into account.
 Please also ensure that sufficient size shaft is chosen for corresponding load.

For correct sprocket position: See uni Assembly Instructions for uni Flex ONE.
 For more detailed sprocket information, contact Customer Service.