

uni Flex Plastic Chain

Series **uni 1400** Type -

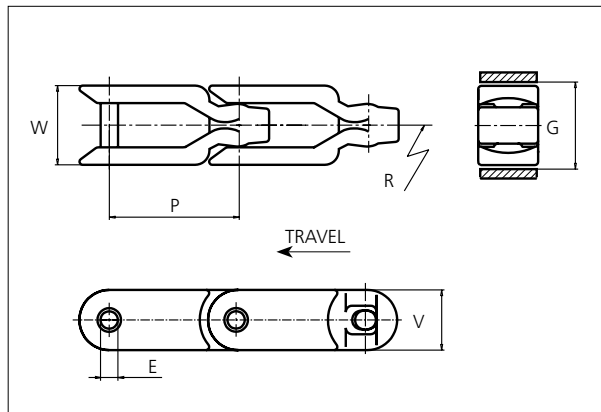

uni Flex Chains
 Side flexing chain
 Pitch: 82.5 mm (3.25 in)
 Backflex radius: 75.0 mm (2.90 in)
 Permissible tensile strength:
 POM material 8000 N (1798 lbf)

 Delivery: 6.1 m (20.0 ft)
 No. of links/box: 74

E		G		P		V	
mm	in	mm	in	mm	in	mm	in
11.0	0.43	54.0	2.13	82.5	3.25	38.0	1.50

All dimensions are for chains in POM material.

Width (W)		Material & color	Pin material	Weight		Min. radius (R)	
mm	in			kg/m	lb/ft	mm	in
50.0	1.97	POM-D W	SS304	2.1	1.41	450	17.72

Non standard material and color: See uni Material and Color Overview.
 Non standard pin material: See uni Material and Color Overview.

STANDARD

SIDE FLEXING

PITCH 82.5 MM/3.25 IN

Any questions? Please contact us.

Morskate Aandrijvingen BV
 Oosterveldsingel 47A
 7558 PJ Hengelo (Ov)
 The Netherlands

NL
 T +31 (0)74 - 760 11 11
 info@morskateaandrijvingen.nl
 www.morskateaandrijvingen.nl

DE
 T +49 692 - 222 34 95
 info@morskateantriebstechnik.de
 www.morskateantriebstechnik.de

EN
 T +31 (0)74 - 760 11 11
 info@morskatedrivetechnology.com
 www.morskatedrivetechnology.com

Sprocket

No of teeth	Pitch diameter		Overall-diameter		Min. ø bore		Max. ø bore		Hub-diameter		A-dimension		B-dimension		Molded PA66 LG	Machined PA66 
	mm	in	mm	in	mm	in	mm	in	mm	in	mm	in	mm	in		
Z6	164.5	6.48	177.0	7.00	20.0	0.80	40.0	1.60	63.0	2.50	52.5	2.10	101.5	4.00		x
Z8	215.2	8.47	227.6	9.00	20.0	0.80	50.0	2.00	75.0	2.95	80.6	3.20	126.8	5.00		x
Z10	266.7	10.50	279.0	11.00	20.0	0.80	50.0	2.00	75.0	2.95	108.0	4.30	152.5	6.00		x

Non standard material and color:
See uni Material and Color Overview.

Machined sprocket

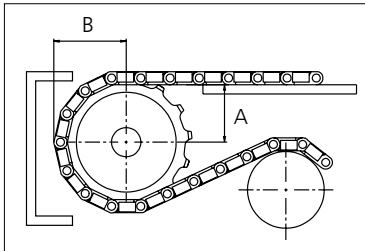

Please ensure that sufficient size shaft and keyway are chosen for corresponding load.

Other sprocket sizes are available upon request
Width of tooth: 15.0 mm/0.59 in
Width of sprocket: 42.3 mm/1.67 in
uni Retainer Rings: See uni Retainer Ring data sheet

Any questions? Please contact us.