

Snap-On Plastic Chain

Series **uni 1843** Type -

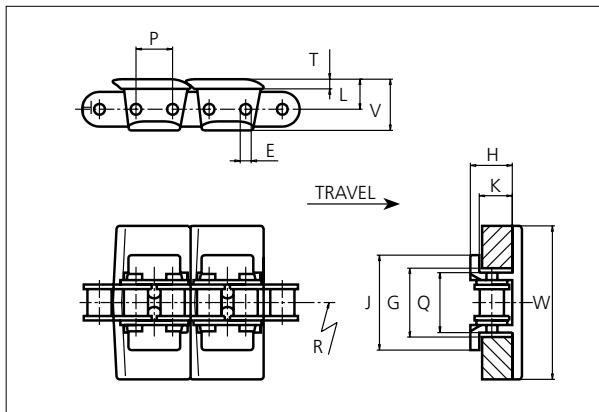

Snap-On Plastic Chain
 Side flexing chain
 Pitch: 12.7 mm (0.50 in)
 Backflex radius: 155.0 mm (6.10 in)
 Permissible tensile strength:
 uni 1843 with (SS304) stainless steel chain: 2000 N (450 lbf)
 uni 1873 with carbon steel chain: 1500 N (3400 lbf)
 Delivery:
 3.048 m (10 ft)
 No. of links/box: 240
 No. of flights/box: 120

STANDARD

E		G		H		J		K		L		P		Q		T		V	
mm	in	mm	in	mm	in	mm	in	mm	in	mm	in	mm	in	mm	in	mm	in	mm	in
3.6	0.14	22.0	0.87	13.8	0.54	31.4	1.24	10.8	0.43	9.3	0.37	12.7	0.50	19.8	0.78	3.3	0.13	17.1	0.67

All dimensions are for chains in POM material.

All Snap-On versions can be delivered either with a stainless steel chain (SS304) or a carbon steel chain.

	Width (W)		Flight material & color	Chain material	Weight		Min. radius R	
	mm	in			kg/m	lb/ft	mm	in
K125	31.5	1.25	POM-LFI BR	SS304 or Carbon steel	0.8	0.54	254.0	10.00
K150	37.9	1.50	-	-	-	-	-	-
K200	50.6	2.00	POM-LFI BR	SS304 or Carbon steel	0.9	0.60	254.0	10.00
K325	82.6	3.25	POM-LFI BR	SS304 or Carbon steel	1.0	0.67	254.0	10.00

Non standard material and color: See uni Material and Color Overview.

Accessories

Rubber Top / NON STANDARD

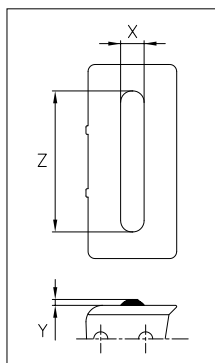

When ordering, please state the required distance between the Rubber Top.

Other Non Standard rubber profiles: See uni Rubber Profile Overview.

Width	Recommended link material	Recommended rubber material	Z		X		Y	
			mm	in	mm	in	mm	in
K125	POM-LFI BR	05 I	25.0	0.98	10.0	0.39	3.0	0.12
K150	POM-LFI BR	05 I	30.0	1.18	10.0	0.39	1.0	0.04
K200	POM-LFI BR	05 I	40.0	1.57	10.0	0.39	0.5	0.02
K325	POM-LFI BR	05 I	60.0	2.32	10.0	0.39	5.0	0.20

SIDE FLEXING

PITCH 12.7 MM/0.50 IN

Any questions? Please contact us.

Sprocket

No of teeth	Pitch diameter		Hub diameter		Overall width L		Tooth width B		Bore		Machined S1045
	mm	in	mm	in	mm	in	mm	in	mm	in	
Z18	73.1	2.88	56.0	2.20	28.0	1.10	7.2	0.28	12.0	0.47	x
Z25	101.3	3.99	70.0	2.76	28.0	1.10	7.2	0.28	14.0	0.55	x

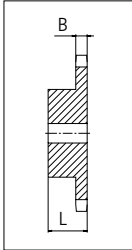

Please ensure that sufficient size shaft and keyway are chosen for corresponding load.

Non standard material and color:
See uni Material and Color Overview.

Other sprocket sizes are available upon request.
uni Retainer Rings: See uni Retainer Ring data sheet.

Any questions? Please contact us.