

Complete Freewheels FA

with lever arm

with sprags and grease lubrication

Morskate®



42-1

Application as

- ▶ Backstop
- ▶ Indexing Freewheel

For application as backstop in installations with low speeds in freewheeling operation. For application as indexing freewheel in installations with low to medium total number of actuations.

Features

Complete Freewheels FA with lever arm are sprag freewheels with sleeve bearings. They are grease-lubricated and therefore maintenance-free.

Besides the standard type, the type with RIDUVIT® is available for extended service life.

Nominal torques up to 2 500 Nm.

Bores up to 85 mm. A multitude of standardized bore diameters are available with short delivery times.

Application example

Complete Freewheel FA 82 SFT as an indexing freewheel for the material feed of a punch. The freewheel is driven by a bell crank. The RIDUVIT® sprags give the freewheel an extended service life.

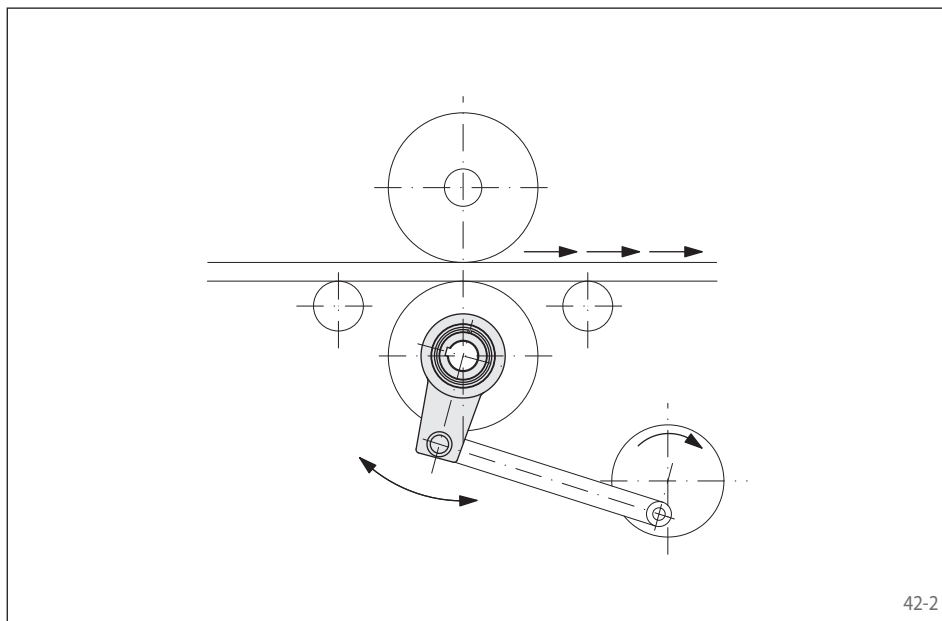

42-2

Any questions? Please contact us.

Morskate Aandrijvingen BV

Oosterveldsingel 47A
7558 PJ Hengelo (Ov)
The Netherlands

NL

T +31 (0)74 - 760 11 11
info@morskateaandrijvingen.nl
www.morskateaandrijvingen.nl

DE

T +49 692 - 222 34 95
info@morskateantriebstechnik.de
www.morskateantriebstechnik.de

EN

T +31 (0)74 - 760 11 11
info@morskatedrivetechnology.com
www.morskatedrivetechnology.com

Complete Freewheels FA

with lever arm
with sprags and grease lubrication

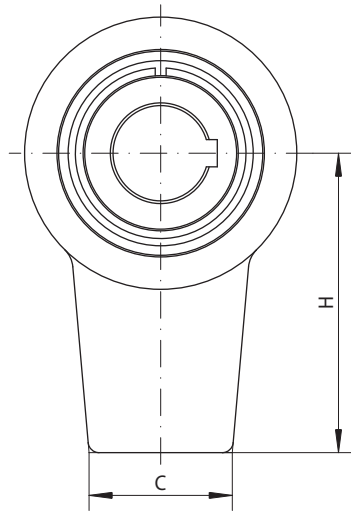

43-1

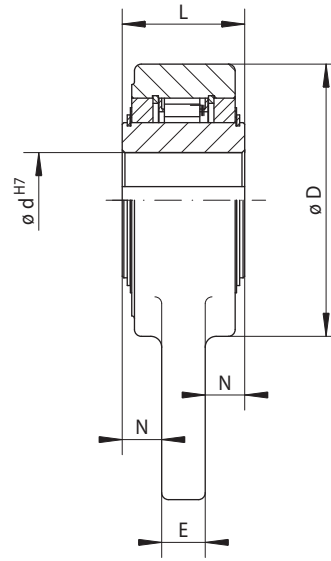

43-2

Indexing Freewheel	Backstop	Standard type	Type with RIDUVIT®	Dimensions
		For universal use	For extended service life with coated sprags	

Freewheel Size	Type	Nominal Torque M_N Nm	Max. speed Inner ring freewheels min^{-1}	Type	Nominal Torque M_N Nm	Max. speed Inner ring freewheels min^{-1}	Bore d		C mm	D mm	E mm	H mm	L mm	N mm	Weight kg
							Standard mm	max. mm							
FA 37	SF	230	250	SFT	230	500	20	25*	35	76	12	90	35	11,5	1,0
FA 57	SF	630	170	SFT	630	340	40	42*	50	100	16	125	45	14,5	2,5
FA 82	SF	1600	130	SFT	1600	260	50	65*	60	140	18	160	60	21,0	5,5
FA 107	SF	2500	90	SFT	2500	180	70	85*	80	170	20	180	65	22,5	8,5

■ Freewheels with bore diameters highlighted blue in the table are available with short delivery times.
The maximum transmissible torque is 2 times the specified nominal torque. See page 14 for determination of selection torque.
Keyway according to DIN 6885, page 1 • Tolerance of keyway width JS10.
* Keyway according to DIN 6885, page 3 • Tolerance of keyway width JS10.

Mounting

When used as a backstop, the backdriving torque is supported by the lever arm. The lever arm must not be clamped into position. It must have 0,5 to 2 mm play in the axial and radial directions.

When used as an indexing freewheel, the lever arm serves as the indexing lever.

The lever arm is not heat treated enabling the customer to provide their own holes.

The tolerance of the shaft must be ISO h6 or j6.

Example for ordering

Freewheel size FA 57, type with RIDUVIT® and 40 mm bore:

- FA 57 SFT, d = 40 mm

Any questions? Please contact us.

Morskate Aandrijvingen BV

Oosterveldsingel 47A
7558 PJ Hengelo (Ov)
The Netherlands

NL

T +31 (0)74 - 760 11 11
info@morskateaandrijvingen.nl
www.morskateaandrijvingen.nl

DE

T +49 692 - 222 34 95
info@morskateantriebstechnik.de
www.morskateantriebstechnik.de

EN

T +31 (0)74 - 760 11 11
info@morskatedrivetechnology.com
www.morskatedrivetechnology.com

Morskate®



Any questions? Please contact us.

Morskate Aandrijvingen BV

Oosterveldsingel 47A
7558 PJ Hengelo (Ov)
The Netherlands

NL

T +31 (0)74 - 760 11 11
info@morskateaandrijvingen.nl
www.morskateaandrijvingen.nl

DE

T +49 692 - 222 34 95
info@morskateantriebstechnik.de
www.morskateantriebstechnik.de

EN

T +31 (0)74 - 760 11 11
info@morskatedrivetechnology.com
www.morskatedrivetechnology.com