

Complete Freewheels FAV

with lever arm

with rollers and grease lubrication

Morskate®



44-1

Application as

- ▶ Backstop
- ▶ Indexing Freewheel

For application as backstop in installations with low speeds in freewheeling operation.

For application as indexing freewheel in installations with low to medium total number of actuations.

Features

Complete Freewheels FAV with lever arm are roller freewheels with sleeve bearings. They are grease-lubricated and therefore maintenance-free.

Nominal torques up to 2 500 Nm.

Bores up to 80 mm.

Application example

Two Complete Freewheels FAV 50 in the roller feed of a sheet metal processing machine. The indexing freewheel arranged on the left is driven via a bell crank with an adjustable lift. This enables an infinite setting of the feed. The backstop arranged on the right prevents the indexing rollers from running backwards while the indexing freewheel carries out its back stroke. Often, an additional small brake is provided in order to prevent the accelerated sheet metal strip from advancing.

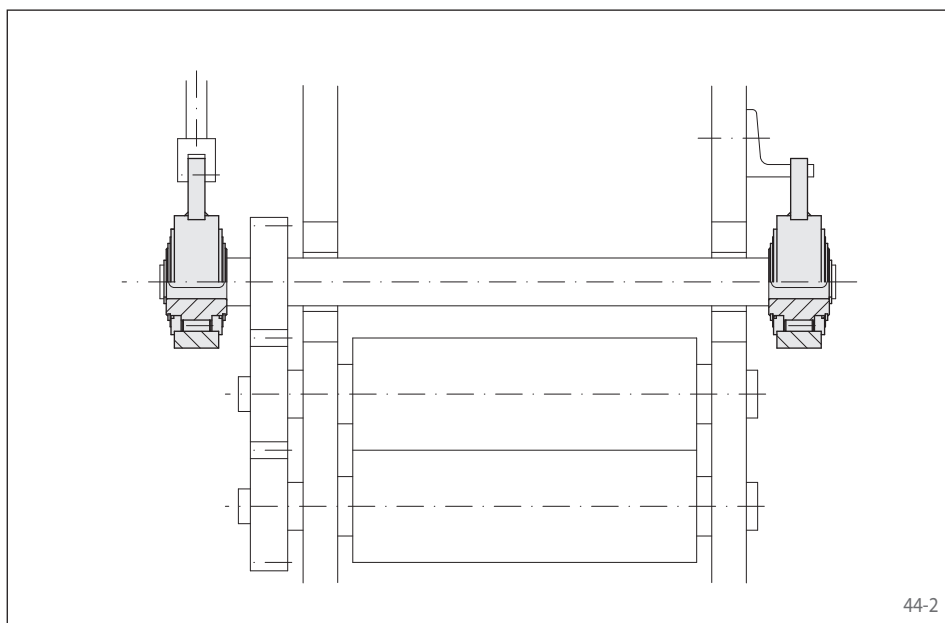

44-2

Any questions? Please contact us.

Morskate Aandrijvingen BV

Costerveldsingel 47A
7558 PJ Hengelo (Ov)
The Netherlands

NL

T +31 (0)74 - 760 11 11
info@morskateaandrijvingen.nl
www.morskateaandrijvingen.nl

DE

T +49 692 - 222 34 95
info@morskateantriebstechnik.de
www.morskateantriebstechnik.de

EN

T +31 (0)74 - 760 11 11
info@morskatedrivetechnology.com
www.morskatedrivetechnology.com

Complete Freewheels FAV

with lever arm
with rollers and grease lubrication

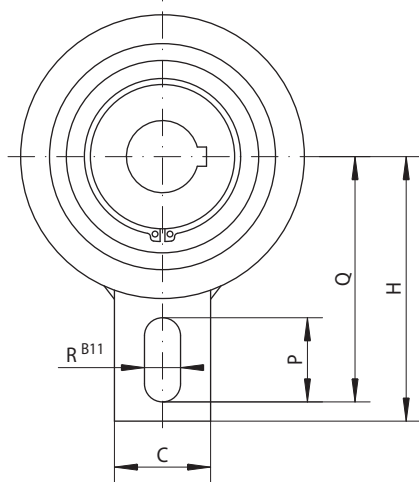

45-1

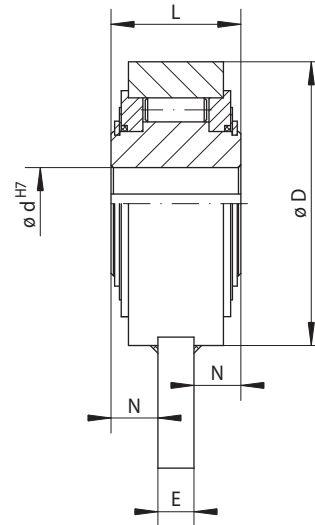

45-2

Indexing Freewheel	Backstop	Standard type	Dimensions											
		For universal use												

Freewheel Size	Nominal Torque M_N Nm	Max. speed Inner ring freewheels min^{-1}	Bore d mm	C mm	D mm	E mm	H mm	L mm	N mm	P mm	Q mm	R mm	Weight kg
FAV 20	220	500	20	40	83	12	90	35	11,5	35	85	15	1,3
FAV 25	220	500	25	40	83	12	90	35	11,5	35	85	15	1,3
FAV 30	1 025	350	30	40	118	15	110	54	19,5	35	102	15	3,5
FAV 35	1 025	350	35	40	118	15	110	54	19,5	35	102	15	3,4
FAV 40	1 025	350	40	40	118	15	110	54	19,5	35	102	15	3,3
FAV 45	1 600	250	45	80	155	20	140	54	17,0	35	130	18	5,5
FAV 50	1 600	250	50	80	155	20	140	54	17,0	35	130	18	5,4
FAV 55	1 600	250	55	80	155	20	140	54	17,0	35	130	18	5,3
FAV 60	1 600	250	60	80	155	20	140	54	17,0	35	130	18	5,2
FAV 70	1 600	250	70	80	155	20	140	54	17,0	35	130	18	5,0
FAV 80	2 500	220	80	80	190	20	155	64	22,0	40	145	20	9,0

■ Freewheels with bore diameters highlighted blue in the table are available with short delivery times.
The maximum transmissible torque is 2 times the specified nominal torque. See page 14 for determination of selection torque.
Keyway according to DIN 6885, page 1 • Tolerance of keyway width JS10.

Mounting

When used as a backstop, the backdriving torque is supported by the lever arm. The lever arm must not be clamped into position. It must have 0,5 to 2 mm play in the axial and radial directions.

When used as an indexing freewheel, the lever arm serves as the indexing lever.

The tolerance of the shaft must be ISO h6 or j6.

Example for ordering

Freewheel size FAV 60, standard type:

- FAV 60

Morskate®



Any questions? Please contact us.

Morskate Aandrijvingen BV

Oosterveldsingel 47A
7558 PJ Hengelo (Ov)
The Netherlands

NL

T +31 (0)74 - 760 11 11
info@morskateaandrijvingen.nl
www.morskateaandrijvingen.nl

DE

T +49 692 - 222 34 95
info@morskateantriebstechnik.de
www.morskateantriebstechnik.de

EN

T +31 (0)74 - 760 11 11
info@morskatedrivetechnology.com
www.morskatedrivetechnology.com