

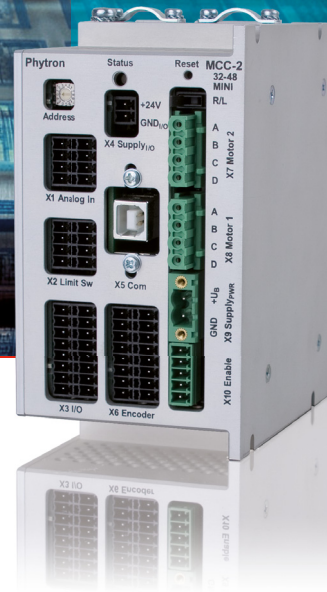

ENG

[www.phytron.eu/MCC-2](http://www.phytron.eu/MCC-2)



## MCC-2

### Programmable controller for two axes

The MCC-2, phytron's freely programmable dual axis stepper motor controller, is a compact stand-alone unit (CPU, Indexer and power stage) for 2 phase stepper motors providing up to 3.5 A<sub>PEAK</sub> phase current.

Controllers in the MCC series have many inputs and outputs (digital and analog) and encoder inputs for step position monitoring plus possibilities to connect limit switches all as standard.

Due to the variety of available host interfaces (Ethernet, Profibus, USB etc.), the MCC can

be quickly and easily integrated into existing applications.

This controller is easy to program and can operate either directly (remote) via its host interface or stand-alone (local) with the program routines stored within.

#### Applications

As a compact stand-alone device, it convinces especially in small experimental setups, machines and equipment, which can be dispensed in a PLC.

#### In Focus

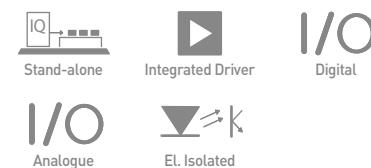

- 2 axes stepper motor control unit with integrated power stages
- Bipolar control of 2 phase stepper motors
- Phase currents up to 3.5 A<sub>PEAK</sub>
- Power supply 24 to 48 V<sub>DC</sub>
- Step resolution 1/1 up to 1/256 step
- Host interfaces: Ethernet, USB, Profibus, RS 485 or RS 232
- Interfaces:
  - 2 encoders
  - 2 analogue inputs
  - 8 digital inputs and 8 outputs
  - 4 limit switches
  - 2 redundant designed enable inputs
- Programming in well-tried MiniLog format, acc. to DIN 66025 or in LabVIEW®
- LabVIEW® driver for including the MCC in your LabVIEW® project
- Remote or local mode

#### Highlights



#### Stand-alone

Once programmed the MCC-2 can work without additional PC/controller.

#### PROFI®BUS

As suggested by our customers now with optional Profibus interface!

#### LabVIEW®

LabVIEW® is a simulation software with a graphical interface. Use the VIs (Virtual Instruments) generated by phytron and integrate them in your LabVIEW® project. So you can easily control the MCC from your usual programming environment.

#### MiniLog-Comm®

MiniLog-Comm® is phytron's communication software running under Windows® to facilitate programming of the stepper motor controller. It provides quick and easy generation of sequential programs.

MiniLog-Comm® software is delivered free with phytron controllers and offers additional functions for test mode, step by step control or single sequence command execution of a motor move, a motor status window and even a Motion Creator.

## Control

## Specification

## Mechanical

Dimensions (W x H x D)	72 x 127 x 110 mm; 90 x 127 x 110 mm with attached USB converter or terminal adaptor
Weight	Approx. 950 g
Mounting	Wall- or rail mounting

## Features

Stepper motors	Suitable for the control of 2 phase stepper motors with 4, (6) or 8 lead wiring
Supply voltage	Controller and motor: 24 to 48 V <sub>DC</sub> ; Limit switches and outputs: 24 V <sub>DC</sub>
Phase current	Up to 3.5 A <sub>PEAK</sub>
Step resolution	1/1, 1/2, 1/4, 1/5, 1/8, 1/10, 1/20; for smoother motor rotation: 1/32, 1/64, 1/128 up to 1/256 step of a full step
Step frequency	40,000 steps/sec
Hardware error detection	<ul style="list-style-type: none"> <li>• Short circuit (between phase and power supply; between both phases; within a motor against ground))</li> <li>• Over temperature</li> <li>• Under voltage</li> </ul>
Cable length	Motor: shielded: 50 m max. Signal: shielded: 100 m max.
Diagnostic LEDs	Ready, busy, error
Operating mode	"Remote" - via bus; "Local" - stand-alone mode with sequence program

## Interfaces

Analogue outputs	2 x (A, B, C, D) for two 2 phase stepper motors
Digital outputs	8 digital outputs, overload-proof, each electrically isolated from power supply / 24 V power supply fed separately; the maximum load is 1 A on each output; 4 A for all outputs
Host interface	Optional: Ethernet, USB, Profibus, RS 485, RS 232
Analogue inputs	2 x 10 Bit AD converter e. g. for a joystick. The joystick power (5 V <sub>DC</sub> ; 100 mA max.) is provided by the controller
Digital inputs	<ul style="list-style-type: none"> <li>• 8 digital inputs, electrically isolated, 24 V input level</li> <li>• 4 limit switches: type PNP NCC or NOC</li> <li>• 2 encoders for optional differential incremental encoder or SSI absolute encoder; provided by the controller (5.3 V<sub>DC</sub>, max. 200 mA)</li> <li>• 2 Motor Enable</li> </ul>

## Communication and Programming

Programming	MiniLog format acc. to DIN 66025 – MiniLog-Comm® (included in delivery) – LabVIEW® VIs (included in delivery)
Memory	128 kB program memory

## Operating Conditions

Temperatures	Operation: +5 to +50 °C; storage and transport: -10 to +85 °C
Degree of pollution	Level 2
Relative humidity	5 to 85 %, class 3K3 non-condensing
Protection class	IP 20
EMC immunity/ EMC emission	Acc. EN 61000-3-2 Acc. EN 61000-6-1, -3, -4 Acc. EN 6100-4-2...6, -11
Approval	CE

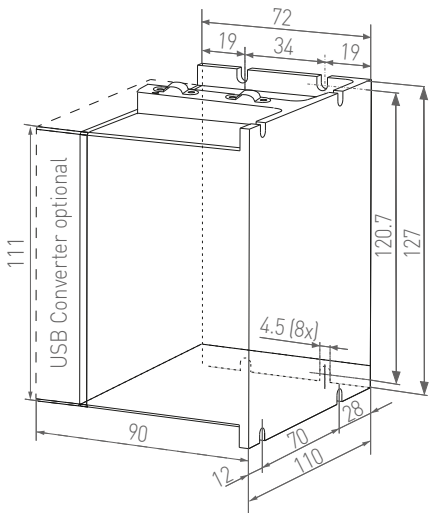

Dimensions in mm

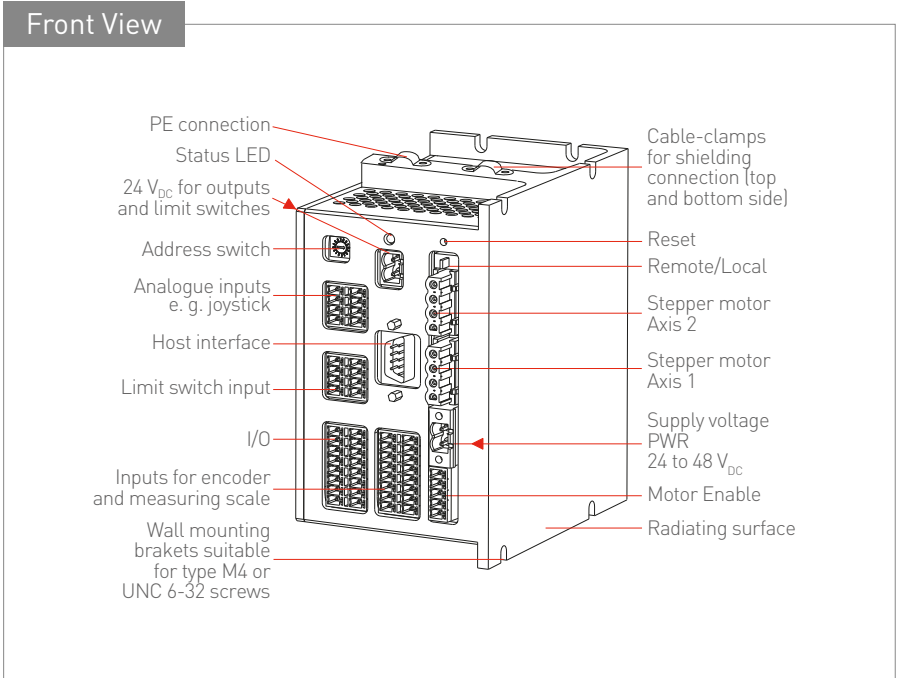

### Block Diagram

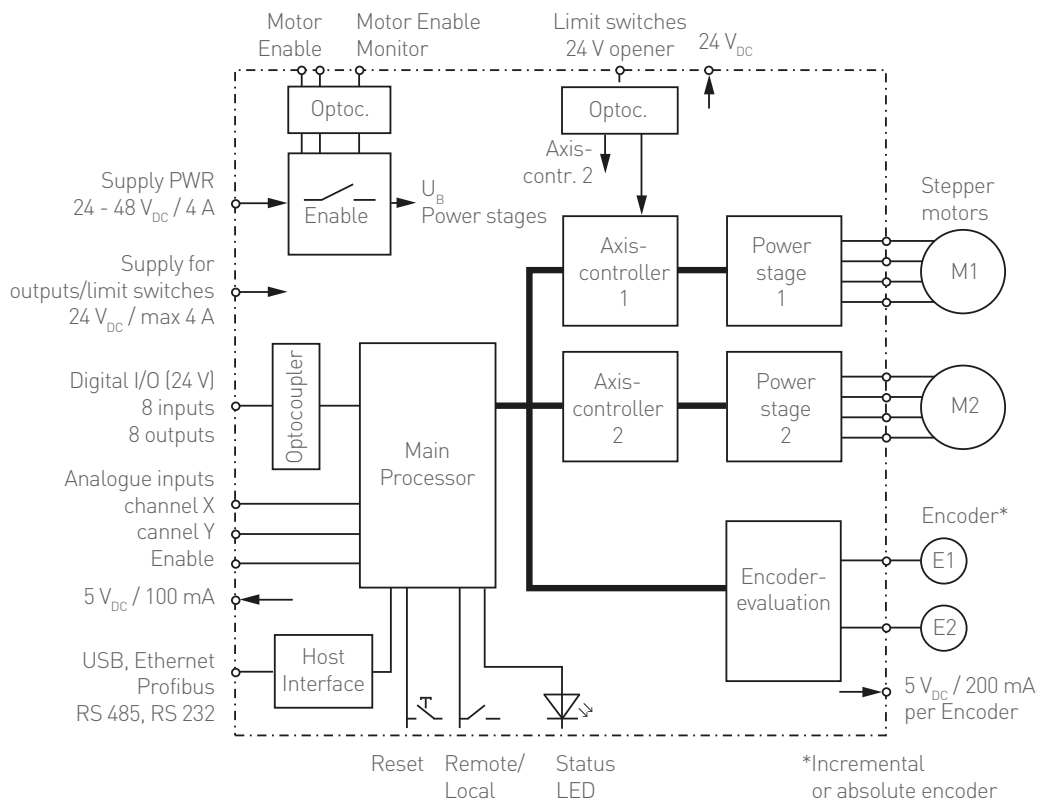

# Control

## Configurations

MCC-2 with RS 232 Port

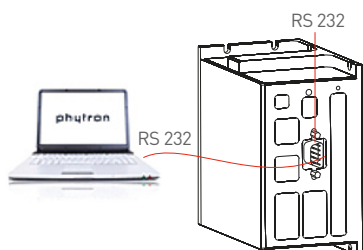

MCC-2 with RS 485 Port / Stand-alone Mode / Bus Mode

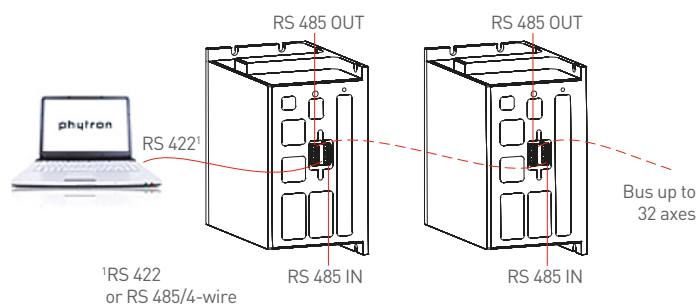

MCC-2 with USB Port

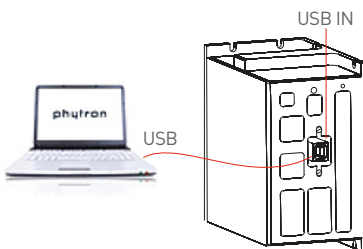

MCC-2 with attached USB Converter and RS 485 Port / Bus Mode

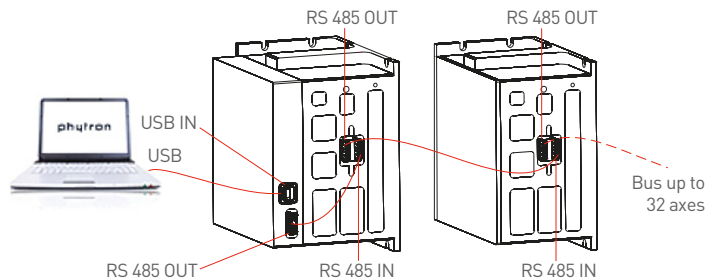

## Ordering Code

The variable elements of the product are displayed in colour.

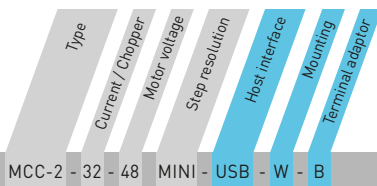

Ordering code

MCC-2 - 32 - 48 MINI - USB - W - B

### Options

Host interface	ETH USB RS 485 RS 485-USB RS 232 PB	Ethernet port USB port RS 485/4-wire port RS 485/4-wire + USB converter RS 232 port Profibus port
Mounting	W H	Wall mounting With attached clip for DIN rail mounting
Adaptor	B	RS 232 adaptor for BT 5 operator terminal

## Extent of Supply

- A CD-ROM with MiniLog-Comm® software, LabVIEW® VIs and USB driver
- Connector set
- Mini USB-RS 485 converter

## Optional Accessories

- Cable assembly
- Power supply unit PS 5-48
- BT 5 operator terminal
- Mini USB-RS 485 converter

Any questions? Please contact us.

**Morskate Aandrijvingen BV**  
Oosterveldsingel 47A  
7558 PJ Hengelo (Ov)  
The Netherlands

NL  
T +31 (0)74 - 760 11 11  
info@morskateaandrijvingen.nl  
www.morskateaandrijvingen.nl

DE  
T +49 692 - 222 34 95  
info@morskateantriebstechnik.de  
www.morskateantriebstechnik.de

EN  
T +31 (0)74 - 760 11 11  
info@morskatedrivetechnology.com  
www.morskatedrivetechnology.com