

# Morskate®

Gedreven door techniek



## De status van een machine op je smartphone?

De Beegle: ons plug & play machine monitoring systeem

Meer weten? [www.beegle.nl](http://www.beegle.nl)

Morskate®





# Falk Lifelign Gear Couplings

(Metric)



# Table Of Contents

DESCRIPTION	PAGE
Falk Lifelign Gear Coupling Application Guide . . . . .	3
How to Select . . . . .	6
Quick Selection Method . . . . .	8
Service Factors . . . . .	10
How to Order . . . . .	11
Products . . . . .	11
 <b>CONTINUOUS SLEEVE GEAR COUPLINGS</b>	
Type GC02 Continuous Sleeve Double Engagement . . . . .	12
Type GC05 Continuous Sleeve Single Engagement . . . . .	13
 <b>STANDARD FLANGED SLEEVE GEAR COUPLINGS</b>	
Type G20 Standard Flanged Sleeve Double Engagement . . . . .	15
Type G32 Standard Flanged Sleeve Spacer . . . . .	16
Type G52 Standard Flanged Sleeve Single Engagement . . . . .	17
Type GV20 Standard Flanged Sleeve Vertical Double Engagement . . . . .	20
Type GV52 Standard Flanged Sleeve Vertical Single Engagement . . . . .	21
Types G62, G63, G66 & G67 Standard Flanged Sleeve Brakewheel/Disc Brake . . . . .	22
Types G62/G66 Standard Flanged Sleeve Brakewheel (for AISE Brakes) . . . . .	23
Type GL20 Standard Flanged Sleeve Slide Double Engagement . . . . .	24
Type GL52 Standard Flanged Sleeve Slide Single Engagement . . . . .	25
Type G70 Disconnect (Inching Drives) . . . . .	26
Type G72 Disconnect . . . . .	27
Type GP20/52/82 Standard Flanged Sleeve Insulated . . . . .	28
Type G82 Standard Flanged Sleeve Rigid . . . . .	29
Type GV82 Standard Flanged Sleeve Rigid Thrust . . . . .	30
Type GR20 Standard Flanged Sleeve Shear Pin/Double Engagement . . . . .	31
Type G Standard Flanged Sleeve Mill Motor & Taper Bores . . . . .	32
 <b>LARGE FLANGED SLEEVE GEAR COUPLINGS</b>	
Type G20 Large Flanged Sleeve Double Engagement . . . . .	33
Type G52 Large Flanged Sleeve Single Engagement . . . . .	34
Type GV20 Large Flanged Sleeve Vertical Double Engagement . . . . .	36
Type GV52 Large Flanged Sleeve Vertical Single Engagement . . . . .	37
Type GL20-4 Large Flanged Sleeve Slide Double Engagement . . . . .	38
Type G70 Large Disconnect . . . . .	39
Type G82 Large Flanged Sleeve Rigid . . . . .	40
Type GR20 Large Flanged Sleeve Shear/Pin Double Engagement . . . . .	41
 <b>TECHNICAL DATA</b>	
Engineering Data — Standard Flanged Sleeve & Continuous Sleeve . . . . .	42
Engineering Data — Large Flanged Sleeve . . . . .	47
Engineering Data — All Gear Couplings . . . . .	51
Lifelign Gear Coupling Nomenclature . . . . .	54
Interchange Guide . . . . .	55
Coupling Application Data Sheet . . . . .	57
Notes . . . . .	58

## Falk Lifelign Gear Coupling Application Guide



**Type GC02 & GC05**

With two hubs and one sleeve, the simplicity of this continuous sleeve coupling allows it to be easily adapted to a wide variety of applications. It's very compact, low in rotating mass, and has a lower initial cost than flanged types. (See **pages 12 and 13.**)

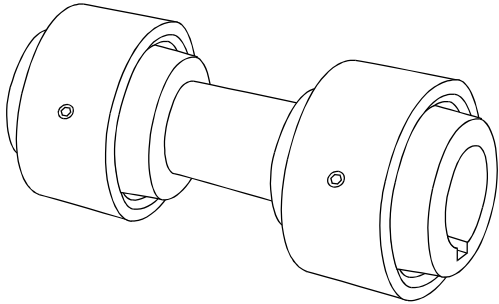

**Type GC05 Floating Shaft**

Floating shaft assemblies are used when the distance between equipment is too great for spacer couplings. A standard floating shaft assembly consists of two standard single engagement couplings and a connecting shaft. A floating shaft can eliminate the need for additional bearing supports along spanning shafts, because the shaft is supported by connected equipment through the single engagement couplings. (See **page 14.**)

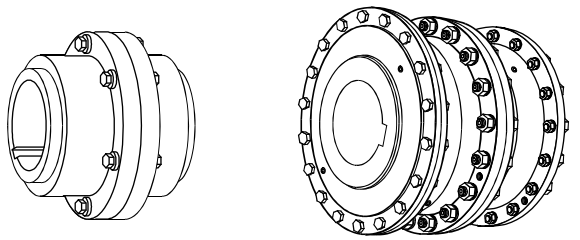

**Types G20, GV20**

**Type G Large Gear Coupling**

The Type G20 double engagement, close-coupled type has two flex halves to accommodate both offset and angular misalignment or a combination of the two, as well as end float. It is ideal for all horizontal, close-coupled applications including fans, overhead cranes, conveyors, steel and paper mill equipment. It is adaptable with limited end float kits for use on electric motors, generators or any machines fitted with sleeve or straight roller bearings. (See **page 15.**)

Type GV20 vertical double engagement coupling is a standard horizontal double engagement gear coupling modified to accommodate the sleeve-centering assembly. Recommended for inclinations over 10°. (See **pages 20 and 36.**)

The Type G Large Gear Coupling is available in all types for capacities up to 8 185 000 Nm, (72,450,000 lb-in). (See **page 33.**)

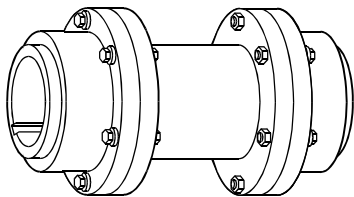

**Types G32**

Spacer couplings for pump and compressor applications simplify servicing connected equipment. Spacer couplings use a standard double engagement coupling with a spacer tube and an additional set of fasteners. Stock spacer lengths for quick delivery are available in the popular sizes. Special lengths are also available. (See **page 16.**)

## Falk Lifelign Gear Coupling Application Guide

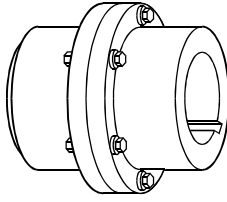

Types G52, GV52

The Type G52 single engagement design is used with floating shafts or three bearing drive trains. It has one flex half and one rigid half and only accepts angular misalignment. (See **pages 17 and 34.**)

The GV52 vertical single engagement gear coupling is a standard horizontal single engagement gear coupling modified to accommodate the sleeve-centering assembly. It is recommended for inclinations over 10°. Downward thrust capacity for Sizes 1010 thru 1030GV52 is 4536 kg; for Sizes 1035 thru 1070GV52, it is 13608 kg and for Sizes 1080GV52 and larger, it is 39463 kg. (See **21 and 37.**)

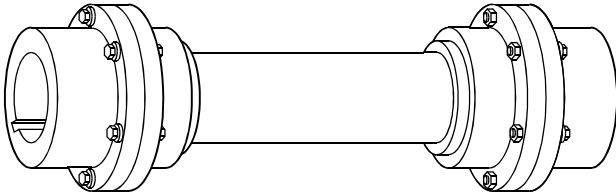

Types G52, GV52

Floating shaft assemblies are used when the distance between equipment is too great for spacer couplings. A standard floating shaft assembly consists of two standard single engagement couplings, two gap discs and a connecting shaft. A floating shaft can eliminate the need for additional bearing supports along spanning shafts, because the shaft is supported by connected equipment through the single engagement couplings. (See **pages 18, 19 and 35.**) When used with a vertical floating shaft on inclinations over 10°, the Type GV52 coupling is used as the lower coupling to support the shaft. (See **pages 21 and 37.**)

Flex Hubs on Floating Shaft (RFFR) — Assembly of the flex hubs on the floating shaft allows for easier replacement and allows the rigid hubs with greater bore capacity to be used on the connected equipment shafts. This frequently means a smaller coupling size can be utilized.

Rigid Hubs on Floating Shaft (FRRF) — When the rigid hubs are on the floating shaft, shorter shaft spans can be accommodated, since no cover drawback is required.

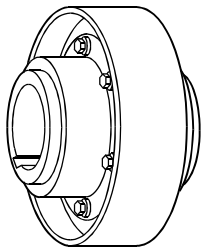

Types G62 & 66

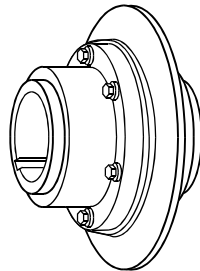

Type G63

Double or single engagement brakewheel and disc brake couplings are used for applications such as cranes, hoists and conveyors. Brakewheel and disc brake couplings accommodate misalignment between connected equipment and eliminate the need for double shaft extensions on motors and gear drives for applications requiring brakes. (See **pages 22 and 23.**)

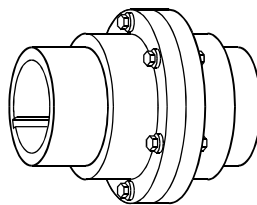

Types GL20 & GL52

Double and single engagement slide couplings are used for applications requiring axial movement to accommodate thermal shaft expansion or adjustment. (See **pages 24, 25 and 38.**)

## Falk Lifelign Gear Coupling Application Guide

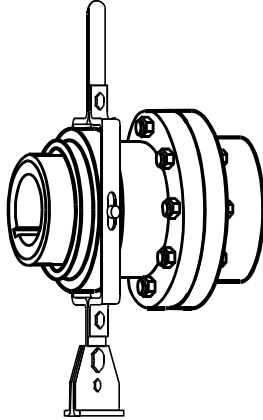

Types G70 & G72

Type G70 disconnect couplings are used for low-speed applications that require quick disconnect of equipment or inching drives. It is used for occasional servicing or inspection of drive system components and is most commonly used on portable or stationary inching drive systems where the driving end hub/sleeve combination is mounted on the driving shaft on the incher for connecting or disconnecting at standstill. (See **pages 26 and 39.**)

Type G72 disconnect couplings were designed for higher speed applications that require quick disconnect such as backup drives. When the long flex hub is mounted on the auxiliary driving shaft, the changeover is performed at standstill by engaging the free-running hub. (See **page 27.**)

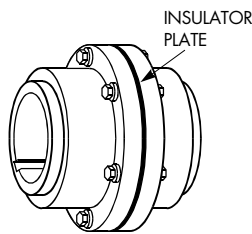

Types GP20, 52 & 82

Double, single or rigid engagement insulated couplings are used to eliminate the flow of stray current from one shaft to another and to protect sensitive electrical equipment. They are not intended to withstand high potential currents, short circuits or static charges. Insulated couplings consist of standard hubs and sleeves and utilize reduced diameter socket head cap screws. The insulator plate is made of a NEMA Grade LE phenolic material, and insulator bushings and washers are made of NEMA Grade G9 phenolic material. (See **page 28.**)

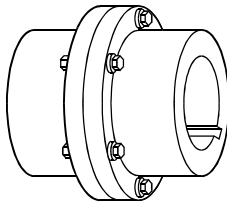

Type G82 & GV82

Rigid couplings are used when there is no need to accommodate misalignment, and where thrust loads are generated, such as vertical mixer applications. (See **pages 29, 30 and 40.**)

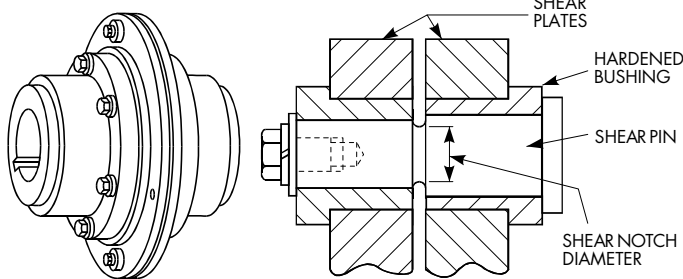

Type GR20

Shear pin couplings are used for applications subject to jamming and overload. When pins break, the equipment is physically disconnected, preventing damage. If desired shear settings are unknown, the selection should be referred to the Factory. (See **pages 31 and 41.**)

# How to Select

## Standard Selection Method

The standard selection method can be used for most motor, turbine or engine-driven applications. The following information is required to select a gear coupling:

- Horsepower or torque.
- Running rpm.
- Application or type of equipment to be connected (motor to pump, gear drive to conveyor, etc.).
- Shaft diameters.
- Shaft gaps.
- Physical space limitations.
- Special bore or finish information and type of fit.

**Exceptions are high peak loads, brake applications or high frequency axial sliding (greater than 5 per hour). For these conditions, use the Formula Selection Method on the next page. Applications that require rapid changes in direction or torque reversals should be referred to the Factory.**

1. **Rating:** Determine system torque. If torque is not given, calculate as shown below:

$$\text{System Torque (Nm)} = \frac{\text{kW} \times 9549}{\text{RPM}}$$

Where: HP (kW) is the actual or transmitted power required by the application (if unknown, use the motor or turbine nameplate rating) and RPM is the actual speed the coupling is rotating.

2. **Service Factor:** Determine the appropriate service factor from **Table 4 and Table 5, page 10** or **Table 6, page 11**.
3. **Required Minimum Coupling Rating:** Determine the required minimum coupling rating as shown below:  
Minimum Coupling Rating = S.F. (Service Factor) x Torque (Nm)
4. **Type:** Refer to **pages 3-5** and select the appropriate coupling type.
5. **Size:** Determine proper size of type selected from **Table 1** by tracing down the torque column to a value that is equal or greater than that determined in Step 3 above. Then turn to the dimension pages of the appropriate coupling type selected and check the following for the size selected.
6. **Check:** Coupling capacities and dimensions.
  - A. Bores — Check shaft diameters against coupling maximum bore. If bore is inadequate, consider the use of a reduced key from engineering tables, or select a larger size coupling.
  - B. Speeds (rpm) — Check the operating rpm against the coupling allowable speed. If cataloged values are inadequate, consider balancing. Balancing may allow up to a 50% increase in the speeds shown. Contact the Factory with complete application details. Check I & M manual or Factory for minimum speed recommendation for NLG11 greases like LTG.
  - C. Dimensions — Checks are: length of hubs and alignment clearances against shaft lengths, outside diameter of coupling against radial clearances.

## Standard Selection Example:

Select a gear coupling to connect a 350 kW, 1000 rpm electric motor to a drive high-speed shaft of a maneuvering winch. Maximum shaft separation is 6 mm. Motor shaft diameter is 85 mm and keyway is 22 mm x 14 mm. Winch shaft diameter is 75 mm and keyway is 20 mm x 12 mm. Motor and winch extensions are both 150 mm long.

1. **Determine Required Rating:**

$$\text{System Torque (Nm)} = \frac{350 \text{ kW} \times 9549}{1000 \text{ RPM}} = 3342$$

2. **Service Factor:** From Service Factor **Table 4, page 10** = 1.5.

3. **Required Minimum Coupling Rating:**

$$1.5 \times 3342 \text{ Nm} = 5013 \text{ Nm}$$

4. **Type:** From **page 3**, to connect close-coupled shafts (6 mm gap) the double engagement Type 1025GC02 or Type 1025G20 coupling is the selection. Refer to **page 12** or **page 15** for dimensions.
5. **Size:** From **page 12**, a Size 1025GC02 or **page 15**, a Size 1025G20 is the proper selection based on a torque rating of 7470 Nm exceeding the required minimum coupling rating of 5013 Nm
6. **Check:** Maximum speed capacity of 3,330 (1025GC02) and 5000 (1025G20) rpm exceeds required speed of 1000 rpm. Maximum bore capacity of 98 mm exceeds the actual shaft diameters.

**Table 1 — Torque and Power Ratings**

Coupling Size	Torque Rating (Nm)	kW per 100 RPM
1010G/GC	1 140	11,9
1015G/GC	2 350	24,6
1020G/GC	4 270	44,7
1025G/GC	7 470	78,3
1030G/GC	12 100	127
1035G/GC	18 500	194
1040G	30 600	321
1045G	42 000	440
1050G	56 600	593
1055G	74 000	775
1060G	90 400	947
1070G	135 000	1 420

Coupling Size		Torque Rating (Nm) x 10 <sup>3</sup>		kW per 100 RPM	
		1000 Series	2000 Series	1000 Series	2000 Series
1080G	2080G	170	234	1780	2450
1090G	2090G	226	315	2360	3300
1100G	2100G	310	443	3250	4640
1110G	2110G	413	609	4320	6380
1120G	2120G	555	777	5810	8140
1130G	2130G	719	925	7530	9690
1140G	2140G	911	1 140	9540	11 900
1150G	2150G	1 100	1 350	11 500	14 200
1160G	2160G	1 310	1 640	13 700	17 100
1180G	2180G	1 660	2 140	17 400	22 400
1200G	2200G	2 140	2 850	22 400	29 800
1220G	2220G	2 720	3 560	28 500	37 300
1240G	2240G	3 470	4 480	36 400	47 000
1260G	2260G	4 490	5 480	47 000	57 400
1280G	2280G	5 840	6 760	61 100	70 800
1300G	2300G	6 760	8 190	70 800	85 700

## How to Select

### Formula Selection Method

The Standard Selection Method can be used for most coupling selections. The procedure below should be used for:

- High Peak Loads
- Brake Applications (Where the disc brake or brakewheel is to be an integral part of the coupling, consult the Factory for design options.)
- High Frequency Axial Sliding
- Shear Pin Couplings

Providing system peak torque and frequency, duty cycle and brake torque rating will allow for a more refined selection using the Formula Selection Method.

1. **High Peak Loads:** Use one of the following formulas for applications using motors with torque characteristics that are higher than normal; applications with intermittent operations, shock loading, inertia effects due to starting and stopping and or system-induced repetitive high peak torques. System Peak Torque is the maximum torque that can exist in the system. Select a coupling with a torque rating equal to or greater than selection torque calculated below.

A. Non-Reversing High Peak Torque

Selection Torque (Nm) = System Peak Torque

or

$$\text{Selection Torque (Nm)} = \frac{\text{System Peak kW} \times 9549}{\text{RPM}}$$

B. Reversing High Peak Torque

Selection Torque (Nm) = 1.5 x System Peak Torque

or

$$\text{Selection Torque (Nm)} = \frac{1.5 \times \text{Peak kW} \times 9549}{\text{RPM}}$$

C. Occasional Peak Torques (Non-reversing) — If a system peak torque occurs less than 1000 times during the expected coupling life, use the following formula:

Selection torque (Nm) = 0.5 x System Peak Torque

or

$$\text{Selection Torque (Nm)} = \frac{0.5 \times \text{Peak kW} \times 9549}{\text{RPM}}$$

For reversing service, select per Step B, above.

2. **Brake Applications:** If the torque rating of the brake exceeds the motor torque, use the brake rating as follows:

Selection Torque (Nm) = Brake Torque Rating x S.F.

3. **High Frequency Axial Sliding:** For Type GL coupling, if axial movement occurs more than 5 times per hour, add 0.25 to the service factor.

$$\text{Selection Torque (Nm)} = \frac{\text{kW} \times 9549 \times (\text{S.F.} + 0.25)}{\text{RPM}}$$

4. **Shear Pin Couplings:** When selecting Type GR couplings, make certain that the required shear torque is within the minimum/maximum range for the coupling size selected. Refer to **pages 31 and 41**.

The user-provided shear torque value must be based on a system analysis. It is recommended that the shear torque value be at least 225% of the normal transmitted torque value for non-reversing applications to avoid breaking the shear pins due to fatigue during motor start-up. For reversing applications, the recommended shear torque setting is 300-400% of normal torque to avoid fatigue failures. If the connected equipment cannot tolerate these torque levels, expect to replace the shear pins more frequently.

**Formula Selection Example** — High Peak Load:

Select a gear coupling to connect a gear drive low-speed shaft to a reversing runout mill table. The electric motor rating is 37 kW at its base speed and the system peak torque at the coupling is estimated to be 17 000 Nm. The coupling speed is 77 rpm at the motor base speed. Drive shaft diameter is 100 mm and key is 28 mm x 16 mm. Runout table roll diameter is 135 mm and key is 36 mm x 20 mm. Shaft separation is 12 mm maximum. Motor and drive shaft extensions are both 180 mm long.

1. **Type:** From **page 3**, to connect close-coupled shafts (12 mm gap), the double engagement Type G20 coupling is the selection.
2. **Required Minimum Coupling Rating:**  
Use the Reversing High Peak Torque formula in Step 1B.  
 $1.5 \times 17\,000 = 25\,500$  Selection Torque
3. **Size:** From **Table 1**, Size 1040G20 coupling with torque rating of 30 600 exceeds the selection torque of 25 500
4. **Check:** The maximum bore of 160 mm, from **Table 13, page 43** the allowable speed of 3600 and Dimension M of 145 mm on **page 15** meet the requirements.

## Quick Selection Method

### 1. Select Coupling Type.

The Type G20 coupling is the proper selection for most industrial applications. For quick disconnect couplings, especially suited for pump applications, consider the Type G32 spacer coupling. If an application requires a special purpose coupling, refer application details to the local Rexnord representative.

### 2. Determine Service Factor.

- A. For motor, turbine or engine-driven applications, refer to **Table 4 and Table 5, page 10**.
- B. For brake, high peak load and Type GL slide coupling applications, refer to Formula Selection Method on **page 7**.

### 3. Determine Equivalent Power.

Refer to **Table 2** below. Under the actual motor kW required and opposite the service factor determined in Step 2, read the equivalent kW.

### 4. Determine Coupling Size.

- A. Refer to **Table 3, page 9**. Trace horizontally from the required speed to a value equal to or larger than the equivalent kW determined in Step 3. Read the coupling size at the top of the column.
- B. Check shaft diameters against coupling maximum bores. If a larger bore is required, select a larger coupling.

- C. Check the required speed against the allowable speed of the coupling selected. If a higher speed is required, refer complete details to the local Rexnord representative.
- D. Check dimensions ... Dimension M in particular.

#### Example:

Select a gear coupling to connect a 250 kW, 68 rpm electric motor to a gear drive high-speed shaft of a maneuvering winch. Maximum shaft separation is 10 mm. Motor shaft diameter is 80 mm and the gear drive shaft is 160 mm. Motor and gear drive shaft extensions are both 153 mm long.

#### Selection:

1. To connect close-coupled shafts (10 mm gap) and to accommodate anticipated shaft misalignment, the double engagement Type G20 coupling shown on **page 15** is the selection.
2. From **Table 4, page 10**, the Service Factor is 1.5.
3. From **Table 2** below, the equivalent kW is 250.
4. From **Table 3, page 9**, the coupling size is 1040G for 68 rpm and equivalent kW of 250. From the table on **page 15**, the maximum bore of 180 mm, allowable speed of 5000 rpm and Dimension M of 92 mm are all satisfactory.

**Table 2 — Equivalent Power = (Actual kW x Service Factor)**

Service Factor ①	Actual kW																														
	0,25	0,37	0,55	0,75	1,1	1,5	2,2	3	4	5,5	7,5	9,2	11	15	18,5	22	30	37	45	55	75	90	110	132	150	185	200	220	250	300	330
1.00	0.25	0.37	0.55	0.75	1.1	1.5	2.2	3	4	5.5	7.5	9.2	11	15	18.5	22	30	37	45	55	75	90	110	132	150	185	200	220	250	300	330
1.25	0.31	0.46	0.69	0.9	1.4	1.9	2.8	3.8	5	6.9	9.4	11.5	13.8	18.8	23.1	27.5	37.5	46.3	56.3	68.8	93.8	113	138	165	188	231	250	275	313	375	413
1.50	0.38	0.56	0.83	1.1	1.7	2.3	3.3	4.5	6.0	8.3	11.3	13.8	16.5	22.5	27.8	33.0	45.0	55.5	67.5	82.5	113	135	165	198	225	278	300	330	375	450	495
1.75	0.44	0.65	0.96	1.3	1.9	2.6	3.9	5.3	7.0	9.6	13.1	16.1	19.3	26.3	32.4	38.5	52.5	64.8	78.8	96.3	131	158	193	231	263	324	350	385	438	525	578
2.00	0.50	0.74	1.1	1.5	2.2	3.0	4.4	6.0	8.0	11.0	15.0	18.4	22.0	30.0	37.0	44.0	60.0	74.0	90.0	110	150	180	220	264	300	370	400	440	500	600	660
2.50	0.63	0.93	1.4	1.9	2.8	3.8	5.5	7.5	10	13.8	18.8	23.0	27.5	37.5	46.3	55.0	75.0	92.5	113	138	188	225	275	330	375	463	500	550	625	750	825
3.00	0.75	1.1	1.7	2.3	3.3	4.5	6.6	9.0	12	16.5	22.5	27.6	33.0	45.0	55.5	66.0	90.0	111	135	165	225	270	330	396	450	555	600	660	750	900	990
3.50	0.88	1.3	1.9	2.6	3.9	5.3	7.7	10.5	14	19.3	26.3	32.2	38.5	52.5	64.8	77.0	105	130	158	193	263	315	385	462	525	648	700	770	875	1050	1155

① For Service Factors not listed, Equivalent kW = Actual kW x Service Factor.

# Quick Selection Method

**Table 3 — Coupling Selection ... Based on Equivalent kW Ratings**

	1010G	1015G	1020G	1025G	1030G	1035G	1040G	1045G	1050G	1055G	1060G	1070G
Max Bore (G10/G20), mm	50	65	78	98	111	134	160	183	200	220	244	289
Max Speed (G10/G20)	8 000	6 500	5 600	5 000	4 400	3 900	3 600	3 200	2 900	2 650	2 450	2 150
Torque (N-m)	1 140	2 350	4 270	7 470	12 100	18 500	30 600	42 000	56 600	74 000	90 400	135 000
kW / rpm	0,119	0,246	0,447	0,783	1,27	1,94	3,21	4,40	5,93	7,75	9,47	14,2
RPM	kW Ratings											
4500	536	1110	2010	3520	—	—	—	—	—	—	—	—
3600	428	886	1610	2820	4570	6980	11600	—	—	—	—	—
3000	357	738	1340	2350	3810	5820	9630	13200	—	—	—	—
2500	298	615	1120	1960	3180	4850	8030	11000	14800	19400	—	—
2100	250	517	939	1640	2670	4070	6740	9240	12500	16300	19900	29800
1800	214	443	805	1410	2290	3490	5780	7920	10700	14000	17000	25600
1750	208	431	782	1370	2220	3400	5620	7700	10400	13600	16600	24900
1450	173	357	648	1140	1840	2810	4650	6380	8600	11200	13700	20600
1170	139	288	523	916	1490	2270	3760	5150	6940	9070	11100	16600
1000	119	246	447	783	1270	1940	3210	4400	5930	7750	9470	14200
870	104	214	389	681	1100	1690	2790	3830	5160	6740	8240	12400
720	85,7	177	322	564	914	1400	2310	3170	4270	5580	6820	10200
650	77,4	160	291	509	826	1260	2090	2860	3850	5040	6160	9230
580	69,0	143	259	454	737	1130	1860	2550	3440	4500	5490	8240
520	61,9	128	232	407	660	1010	1670	2290	3080	4030	4920	7380
420	50,0	103	188	329	533	815	1350	1850	2490	3260	3980	5960
350	41,7	86,1	156	274	445	679	1120	1540	2080	2710	3310	4970
280	33,3	68,9	125	219	356	543	899	1230	1660	2170	2650	3980
230	27,4	56,6	103	180	292	446	738	1010	1360	1780	2180	3270
190	22,6	46,7	84,9	149	241	369	610	836	1130	1470	1800	2700
155	18,4	38,1	69,3	121	197	301	498	682	919	1200	1470	2200
125	14,9	30,8	55,9	97,9	159	243	401	550	741	969	1180	1780
100	11,9	24,6	44,7	78,3	127	194	321	440	593	775	947	1420
84	10,0	20,7	37,5	65,8	107	163	270	370	498	651	795	1190
68	8,09	16,7	30,4	53,2	86,4	132	218	299	403	527	644	966
56	6,66	13,8	25,0	43,8	71,1	109	180	246	332	434	530	795
45	5,36	11,1	20,1	35,2	57,2	87,3	144	198	267	349	426	639
37	4,40	9,10	16,5	29,0	47,0	71,8	119	163	219	287	350	525
30	3,57	7,38	13,4	23,5	38,1	58,2	96,3	132	178	233	284	426
25	2,98	6,15	11,2	19,6	31,8	48,5	80,3	110	148	194	237	355
20	2,38	4,92	8,94	15,7	25,4	38,8	64,2	88,0	119	155	189	284
16,5	1,96	4,06	7,38	12,9	21,0	32,0	53,0	72,6	97,8	128	156	234
13,5	1,61	3,32	6,03	10,6	17,1	26,2	43,3	59,4	80,1	105	128	192
11	1,31	2,71	4,92	8,61	14,0	21,3	35,3	48,4	65,2	85,3	104	156
9	1,07	2,21	4,02	7,05	11,4	17,5	28,9	39,6	53,4	69,8	85,2	128
7,5	0,893	1,85	3,35	5,87	9,53	14,6	24,1	33,0	44,5	58,1	71,0	107
5	0,595	1,23	2,24	3,92	6,35	9,70	16,1	22,0	29,7	38,8	47,4	71,0

# Service Factors

**Table 4 — Flexible Coupling Service Factors for Motor ① and Turbine**

Service factors listed are typical values based on normal operation of the drive systems.

Application	Service Factor	Application	Service Factor
<b>AERATOR</b> .....	2.0	<b>HAMMERMILL</b> .....	1.75
<b>AGITATORS</b>		<b>LAUNDRY WASHER OR TUMBLER</b> .....	2.0
Vertical and Horizontal		<b>LINE SHAFTS</b>	
Screw, Propeller, Paddle.....	1.0	Any Processing Machinery.....	1.5
<b>BARGE HAUL PULLER</b> .....	1.5	<b>MACHINE TOOLS</b>	
<b>BLOWERS</b>		Auxiliary and Traverse Drive.....	1.0
Centrifugal.....	1.0	Bending Roll, Notching Press, Punch Press,	
Lobe or Vane.....	1.25	Planer, Plate Reversing.....	1.75
<b>CAR DUMPERS</b> .....	2.5	Main Drive.....	1.5
<b>CAR PULLERS</b> .....	1.5	<b>MAN LIFTS</b> .....	<b>Not Approved</b>
<b>CAR SHREDDER</b> .....	3.0	<b>METAL FORMING MACHINES</b>	
<b>CLARIFIER OR CLASSIFIER</b> .....	1.0	Continuous Caster.....	1.75
<b>COMPRESSORS</b>		Draw Bench Carriage and Main Drive.....	2.0
Centrifugal.....	1.0	Extruder.....	2.0
Rotary, Lobe or Vane.....	1.25	Farming Machine and Forming Mills.....	2.0
Rotary, Screw.....	1.0	Slitters.....	1.0
Reciprocating.....	1.0	Wire Drawing or Flattening.....	1.75
Direct Connected.....	Refer to Factory	Wire Winder.....	1.5
Without Flywheel.....	Refer to Factory	Coilers and Uncoilers.....	1.5
② With Flywheel and Gear between Compressor		<b>MIXERS (see Agitators)</b>	
and Prime Mover		Concrete.....	1.75
1 cylinder, single acting.....	3.0	Muller.....	1.5
1 cylinder, double acting.....	3.0	<b>PRESS, PRINTING</b> .....	1.5
2 cylinders, single acting.....	3.0	<b>PUG MILL</b> .....	1.75
2 cylinders, double acting.....	3.0	<b>PULVERIZERS</b>	
3 cylinders, single acting.....	3.0	Hammermill and Hog.....	1.75
3 cylinders, double acting.....	2.0	Roller.....	1.5
4 or more cyl., single act.....	1.75	<b>PUMPS</b>	
4 or more cyl., double act.....	1.75	Boiler Feed.....	1.5
<b>③ CONVEYORS</b>		Centrifugal — Constant Speed.....	1.0
Apron, Assembly, Belt, Chain, Flight, Screw.....	1.0	Frequent Speed Changes Under Load.....	1.25
Bucket.....	1.25	Descaling, with accumulators.....	1.25
Live Roll, Shaker and Reciprocating.....	3.0	Gear, Rotary, or Vane.....	1.25
<b>③④ CRANES AND HOIST</b>		Reciprocating, Plunger Piston	
Main Hoist.....	1.75 ④	1 cyl., single or double act.....	3.0
Skip Hoist.....	1.75 ④	2 cyl., single acting.....	2.0
Slope.....	1.5	2 cyl., double acting.....	1.75
Bridge, Travel or Trolley.....	1.75	3 or more cylinders.....	1.5
<b>DYNAMOMETER</b> .....	1.0	Screw Pump, Progressing Cavity.....	1.25
<b>ELEVATORS</b>		Vacuum Pump.....	1.25
Bucket, Centrifugal Discharge.....	1.25	<b>SCREENS</b>	
Freight or Passenger.....	<b>Not Approved</b>	Air Washing.....	1.0
Gravity Discharge.....	1.25	Grizzly.....	2.0
<b>ESCALATORS</b> .....	<b>Not Approved</b>	Rotary Coal or Sand.....	1.5
<b>EXCITER, GENERATOR</b> .....	1.0	Vibrating.....	2.5
<b>EXTRUDER, PLASTIC</b> .....	1.5	Water.....	1.0
<b>FANS</b>		<b>SKI TOWS &amp; LIFTS</b> .....	<b>Not Approved</b>
Centrifugal.....	1.0	<b>STEERING GEAR</b> .....	1.0
Cooling Tower.....	2.0	<b>STOKER</b> .....	1.0
Forced Draft — Across the Line start.....	1.5	<b>TIRE SHREDDER</b> .....	1.50
Forced Draft Motor driven thru fluid		<b>TUMBLING BARREL</b> .....	1.75
or electric slip clutch.....	1.0	<b>WINCH, MANEUVERING</b>	
Gas Recirculating.....	1.5	Dredge, Marine.....	1.5
Induced Draft with damper control		<b>WINDLASS</b> .....	1.5
or blade cleaner.....	1.25	<b>WOODWORKING MACHINERY</b> .....	1.0
Induced Draft without controls.....	2.0	<b>WORK LIFT PLATFORMS</b> .....	<b>Not Approved</b>
<b>FEEDERS</b>			
Apron, Belt, Disc, Screw.....	1.0		
Reciprocating.....	2.5		
<b>GENERATORS</b>			
Even Load.....	1.0		
Hoist or Railway Service.....	1.5		
Welder Load.....	2.0		

- ① Add 0.25 to the required service factor for Type GL slide coupling applications where axial movement occurs more than 5 times per hour. When electric motors, generators, engines, compressors and other machines are fitted with sleeve or straight roller bearings, use limited axial end float couplings to protect the bearings. Order limited end float discs with the coupling.
- ② For balanced opposed design, refer to the Factory.
- ③ If people are occasionally transported, refer to the Factory for the selection of the proper size coupling.
- ④ For high peak load applications (such as Metal Rolling Mills) refer to the Factory.

**Table 5 — Engine Drive Service Factors ①**

Service Factors (S. F.) for engine drives are those required for applications where good flywheel regulation prevents torque fluctuations greater than ±20%. For drives where torque fluctuations are greater or where the operation is near a serious critical or torsional vibration, a mass elastic study is necessary.

No. of Cylinders	4 or 5 ①					6 or more ①				
	1.0	1.25	1.5	1.75	2.0	1.0	1.25	1.5	1.75	2.0
<b>Table 4 S.F.</b>	1.0	1.25	1.5	1.75	2.0	1.0	1.25	1.5	1.75	2.0
<b>Engine S.F.</b>	2.0	2.25	2.5	2.75	3.0	1.5	1.75	2.0	2.25	2.5

- ① To use **Table 5**, first determine application service factor from **Table 4**. Use that factor to determine Engine Service Factor from **Table 5**. When service factor from **Table 4** is greater than 2.5, refer complete application details to the Factory for engineering review.







# Drives

Industry	Service Factor	Industry	Service Factor
<b>AGGREGATE PROCESSING, CEMENT, MINING KILNS; TUBE, ROD AND BALL MILLS</b>		Shear, Croppers.....	Refer to Factory
Direct or on L.S. shaft of Reducer,		Sideguards.....	3.0
with final drive Machined Spur Gears.....	2.0	Skeip Mills.....	Refer to Factory
Single Helical or Herringbone Gears.....	1.75	Slitters, Steel Mill only.....	1.75
Conveyors, Feeders, Screens,		Soaking Pit Cover Drives —	
Elevators.....	See General Listing	Lift.....	1.0
Crushers, Ore or Stone.....	2.5	Travel.....	2.0
Dryer, Rotary.....	1.75	Straighteners.....	2.0
Grizzly.....	2.0	Unscramblers (Billet Bundle Busters).....	2.0
Hammermill or Hog.....	1.75	Wire Drawing Machinery.....	1.75
Tumbling Mill or Barrel.....	1.75	<b>OIL INDUSTRY</b>	
<b>BREWING AND DISTILLING</b>		Chiller.....	1.25
Bottle and Can Filling Machines.....	1.0	Oilwell Pumping (not over 150% peak torque).....	2.0
Brew Kettle.....	1.0	Paraffin Filter Press.....	1.5
Cookers, Continuous Duty.....	1.25	Rotary Kiln.....	2.0
Lauter Tub.....	1.5	<b>PAPER MILLS</b>	
Mash Tub.....	1.25	Barker Auxiliary, Hydraulic.....	2.0
Scale Hopper, Frequent Peaks.....	1.75	Barker, Mechanical.....	2.0
<b>CLAY WORKING INDUSTRY</b>		Barking Drum	
Brick Press, Briquette Machine, Clay Working		L.S. shaft of reducer with final drive - Helical	
Machine, Pug Mill.....	1.75	or Herringbone Gear.....	2.0
<b>DREDGES</b>		Machined Spur Gear.....	2.5
Cable Reel.....	1.75	Cast Tooth Spur Gear.....	3.0
Conveyors.....	1.25	Beater & Pulper.....	1.75
Cutter head, Jig Drive.....	2.0	Bleachers, Coaters.....	1.0
Maneuvering Winch.....	1.5	Calender & Super Calender.....	1.75
Pumps (uniform load).....	1.5	Chipper.....	2.5
Screen Drive, Stacker.....	1.75	Converting Machine.....	1.25
Utility Winch.....	1.5	Couch.....	1.75
<b>FOOD INDUSTRY</b>		Cutter, Felt Whipper.....	2.0
Beet Slicer.....	1.75	Cylinder.....	1.75
Bottling, Can Filling Machine.....	1.0	Dryer.....	1.75
Cereal Cooker.....	1.25	Felt Stretcher.....	1.25
Dough Mixer, Meat Grinder.....	1.75	Fourdrinier.....	1.75
<b>LUMBER</b>		Jordan.....	2.0
Band Resaw.....	1.5	Log Haul.....	2.0
Circular Resaw, Cut-off.....	1.75	Line Shaft.....	1.5
Edger, Head Rig, Hog.....	2.0	Press.....	1.75
Gang Saw (Reciprocating).....	Refer to Factory	Pulp Grinder.....	1.75
Log Haul.....	2.0	Reel, Rewinder, Winder.....	1.5
Planer.....	1.75	Stock Chest, Washer, Thickener.....	1.5
Rolls, Non-Reversing.....	1.25	Stock Pumps, Centrifugal	
Rolls, Reversing.....	2.0	Constant Speed.....	1.0
Sawdust Conveyor.....	1.25	Frequent Speed Changes Under Load.....	1.25
Slab Conveyor.....	1.75	Suction Roll.....	1.75
Sorting Table.....	1.5	Vacuum Pumps.....	1.25
Trimmer.....	1.75	<b>RUBBER INDUSTRY</b>	
<b>④ METAL ROLLING MILLS</b>		Calender.....	2.0
Coilers (Up or Down) Cold Mills only.....	1.5	Cracker, Plasticator.....	2.5
Coilers (Up or Down) Hot Mills only.....	2.0	Extruder.....	1.75
Coke Plants		Intensive or Banbury Mixer.....	2.5
Pusher Ram Drive.....	2.5	Mixing Mill, Refiner or Sheeter	
Door Opener.....	2.0	One or two in line.....	2.5
Pusher or Larry Car Traction Drive.....	3.0	Three or four in line.....	2.0
Continuous Caster.....	1.75	Five or more in line.....	1.75
Cold Mills — Strip Mills.....	Refer to Factory	Tire Building Machine.....	2.5
Temper Mills.....	Refer to Factory	Tire & Tube Press Opener (Peak Torque).....	1.0
Cooling Beds.....	1.5	Tuber, Strainer, Pelletizer.....	1.75
Drawbench.....	2.0	Warming Mill	
Feed Rolls - Blooming Mills.....	3.0	One or two Mills in line.....	2.0
Furnace Pushers.....	2.0	Three or more Mills in line.....	1.75
Hot and Cold Saws.....	2.0	Washer.....	2.5
Hot Mills —		<b>SEWAGE DISPOSAL EQUIPMENT</b>	
Strip or Sheet Mills.....	Refer to Factory	Bar Screen, Chemical Feeders, Collectors,	
Reversing Blooming.....	Refer to Factory	Dewatering Screen, Grit Collector.....	1.0
Slabbing Mills.....	Refer to Factory	<b>SUGAR INDUSTRY</b>	
Edger Drives.....	Refer to Factory	Cane Carrier & Leveler.....	1.75
Ingot Cars.....	2.0	Cane Knife & Crusher.....	2.0
Manipulators.....	3.0	Mill Stands, Turbine Driver with all Helical	
Merchant Mills.....	Refer to Factory	or Herringbone gears.....	1.5
Mill Tables		Electric Drive or Steam Engine Drive with Helical,	
Roughing Breakdown Mills.....	3.0	Herringbone, or Spur Gears	
Hot Bed or Transfer, non-reversing.....	1.5	with any Prime Mover.....	1.75
Runout, reversing.....	3.0	<b>TEXTILE INDUSTRY</b>	
Runout, non-reversing, non-plugging.....	2.0	Batcher.....	1.25
Reel Drives.....	1.75	Calender, Card Machine.....	1.5
Rod Mills.....	Refer to Factory	Cloth Finishing Machine.....	1.5
Screwdown.....	2.0	Dry Can, Loom.....	1.5
Seamless Tube Mills		Dyeing Machinery.....	1.25
Piercer.....	3.0	Knitting Machine.....	Refer to Factory
Thrust Block.....	2.0	Mangle, Napper, Soaper.....	1.25
Tube Conveyor Rolls.....	2.0	Spinner, Tenter Frame, Winder.....	1.5
Reeler.....	2.0		
Kick Out.....	2.0		

## Service Factors

**SERVICE FACTORS** are a guide, based on experience, of the ratio between coupling catalog rating and system characteristics. The system characteristics are best measured with a torque meter.

**Table 6 — Service Factors**

Torque Demands Driven Machine	Typical applications for electric motor or turbine driven equipment	Typical Service Factor
	Constant torque such as Centrifugal Pumps, Blowers and Compressors.	1.0
	Continuous duty with some torque variations including Plastic Extruders, Forced Draft Fans.	1.5
	Light shock loads from Metal Extenders, Cooling Towers, Cane Knife, Log Haul.	2.0
	Moderate shock loading as expected from a Car Dumper, Stone Crusher, Vibrating Screen.	2.5
	Heavy shock load with some negative torques from Roughing Mills, Reciprocating Pumps, Compressors, Reversing Runout Tables.	3.0
	Applications like Reciprocating Compressors with frequent torque reversals, which do not necessarily cause reverse rotations.	Refer to Factory

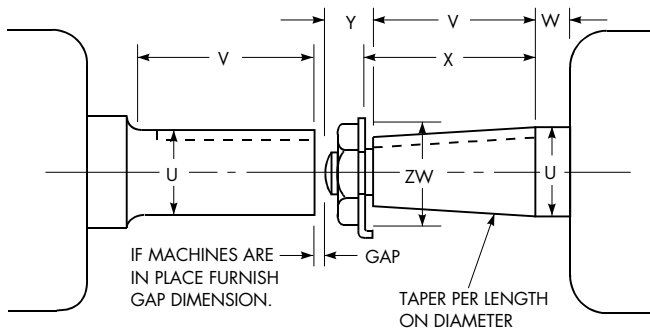

## Products

### Safety Notes

Install and operate Rexnord® products in conformance with applicable local and national safety codes and per Rexnord installation manuals which are available upon request. Suitable guards for rotating members may be purchased from Rexnord as optional accessories. Consult your local Rexnord representative for complete details.

**WARNING:** Lock out power and remove all external loads from the system before attempting to service any component in the system. Locking out the power and removing the load will reduce the possibility of unexpected motion or reaction in the system.

**Falk Long Term Grease (LTG)** — Benefits include: increased coupling life, significantly extended re-lubrication intervals, reduced maintenance costs, reduced downtime, superior lubrication, high load-carrying capabilities and it is usable up to 121°C (250°F).

For information on Falk LTG, request Form 840201B. Lifalign gear couplings are warranted for 3 years when lubricated with Falk LTG.

## How to Order

The following information is necessary to quote or ship to your exact requirements. Prompt service is assured if this information is given on your inquiry or order.

1. Application: Driver & Driven
2. Power: Normal hp, Maximum kW or Torque (Nm)
3. Speed (rpm)
4. Quantity
5. Coupling Size and Type, Horizontal, Vertical; e. g., Size 1010, Type G20
6. Shaft gap or distance between shaft ends (BE Dimension)
7. Bore Sizes will be furnished as per **Table 36, page 53** unless specified differently.
8. Shaft Dimensions as follows:

### For Straight Shafts:

Driving Shaft	Driven Shaft
Diameter U _____	Diameter U _____
Length V _____	Length V _____
Keyway _____	Keyway _____

**NOTE:** Provide shaft tolerances if different than those shown in **Table 24, page 48**. For other shaft/bore requirements, consult Rexnord.

### For Taper Shafts:

Diameter U _____	Across Flats _____
Length V _____	Corners ZW _____
Length W _____	Taper per Foot _____
Length X _____	Keyway _____
Length Y _____	

### Warranty

We're so confident in the performance and reliability of our latest generation of Falk gear drives that we're backing this comprehensive offering with the best standard warranty in the business. Our full, 3-year Heavy-Duty Warranty provides "shaft-to-shaft" protection on all Falk components – including bearings and seals. It's an industry first... and one more powerful reason why Rexnord is your ultimate bottom-line drive and coupling value.①

① Warranty extends for 3 years from date of shipment.

### General Information

- Rexnord standards apply unless otherwise specified.
- Dimensions are for reference only and are subject to change without notice unless certified.
- Unless otherwise specified, Rexnord coupling hubs will be bored for an interference fit without a setscrew. Clearance fit hubs with a setscrew can be supplied if specified.

## Type GC02 Continuous Sleeve Double Engagement

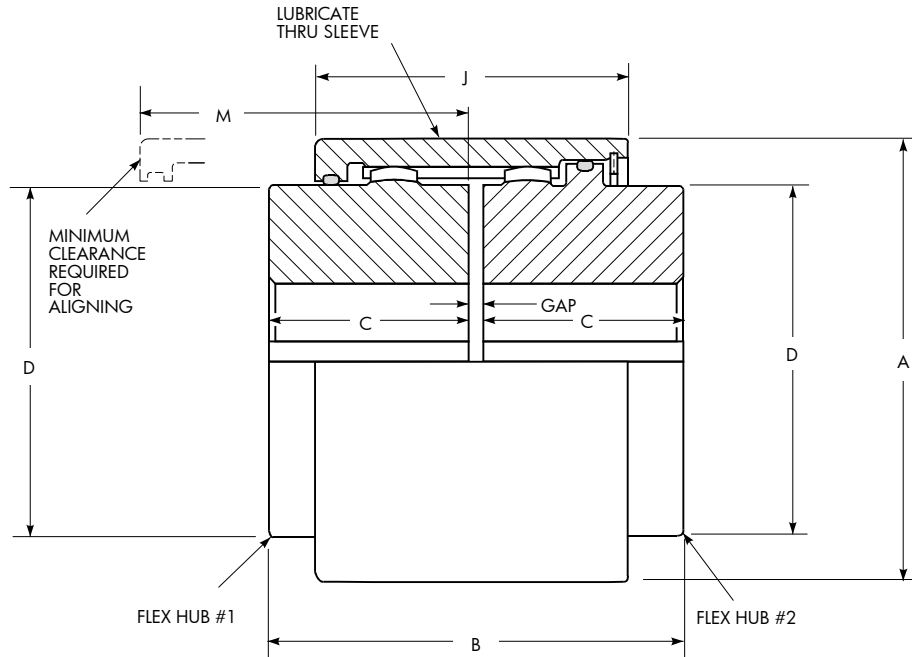

### Dimensions (mm)

Size ①	Torque Rating (Nm) ②	Allow Speed RPM ③	Max Bore (mm) ④	Min Bore ⑤	Cplg Wt with No Bore kg	Lube Wt (kg)	A	B	C	D	J	M	GAP
1010GC	1 140	5300	50	12,7	3,45	0,0113	88,9	88,8	42,9	68,6	61,2	65	3
1015GC	2 350	4300	65	19,0	6,17	0,0283	109,2	101,6	49,3	86,4	76,2	81	3
1020GC	4 270	3700	78	25,4	11,3	0,0425	132,1	127,0	62,0	105,2	94,5	99	3
1025GC	7 470	3300	98	31,8	21,3	0,0652	163,6	159,0	77,0	130,6	109,1	116	5
1030GC	12 100	2900	111	38,1	34,0	0,0936	190,5	187,4	91,2	152,4	119,9	126	5
1035GC	18 500	2600	134	50,8	51,7	0,1219	215,9	218,8	106,4	177,8	133,5	140	6

① See **page 11** for General Information.

② Peak torque capacity is two times the published rating.

③ Consult Factory for higher speeds. Balancing may allow up to a 50% increase in speeds shown.

④ Maximum bores are reduced for hubs furnished with an interference fit and a setscrew over the keyway. Maximum bores may also be reduced when puller bolt holes are required. Refer to **Table 13 and Table 14, page 43**. Bore capacities can be increased beyond values shown if the coupling torque rating is reduced. Refer to the Factory. Recommended key sizes for the listed maximum bores are shown in **Table 35, page 52**.

⑤ Minimum bore is the smallest bore to which a Rough Stock Bore (RSB) hub can be bored. Depending upon coupling size, RSB hubs may have only a blind centering hole or a through hole that will permit remachining of the hubs to the minimum bores specified.

## Type GC05 Continuous Sleeve Single Engagement

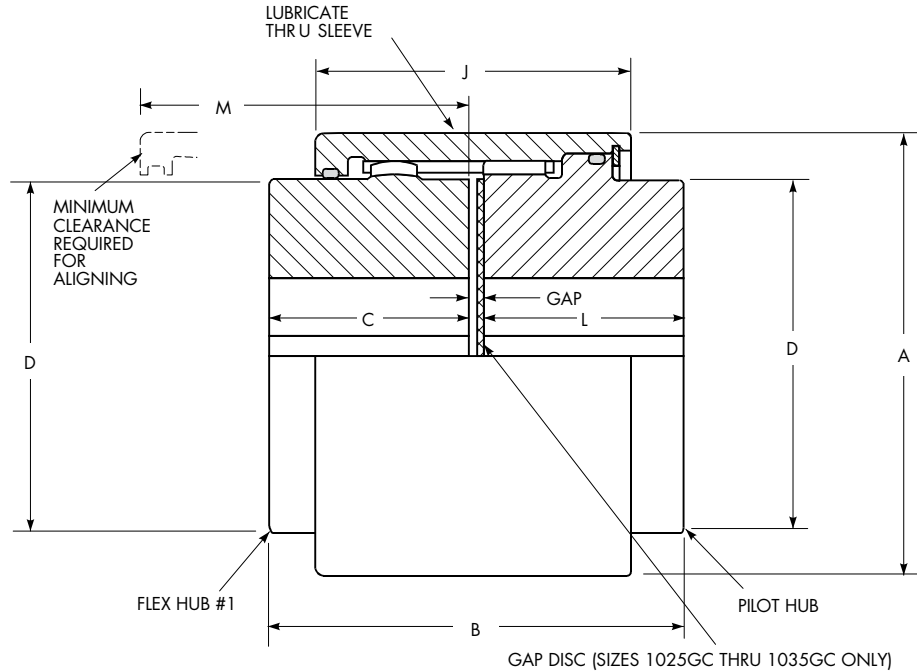

### Dimensions (mm)

Size ①	Torque Rating (Nm) ②	Allow Speed RPM ③	Max Bore (mm) ④	Min Bore (mm) ⑤	Cplg Wt with No Bore (kg)	Lube Wt (kg)	A	B	C	D	J	L	M	GAP
1010GC	1 140	5300	50	12,7	3,49	0,00850	88,9	88,9	42,9	68,6	61,2	42,9	65	3
1015GC	2 350	4300	65	19,0	6,40	0,0198	109,2	103,6	49,3	86,4	76,2	51,1	81	3
1020GC	4 270	3700	78	25,4	11,7	0,0312	132,1	128,8	62,0	105,2	94,5	63,8	99	3
1025GC	7 470	3300	98	31,8	21,8	0,0522	163,6	158,8	77,0	130,6	109,1	77,0	116	5
1030GC	12 100	2900	111	38,1	34,6	0,0730	190,5	187,2	91,2	152,4	119,9	91,2	126	5
1035GC	18 500	2600	134	50,8	52,2	0,0957	215,9	219,2	106,4	177,8	133,5	106,4	140	6

① See **page 11** for General Information.

② Peak torque capacity is two times the published rating.

③ Consult Factory for higher speeds. Balancing may allow up to a 50% increase in speeds shown.

④ Maximum bores are reduced for hubs furnished with an interference fit and a setscrew over the keyway. Maximum bores may also be reduced when puller bolt holes are required. Refer to **Table 13 and Table 14, page 43**. Bore capacities can be increased beyond values shown if the coupling torque rating is reduced. Refer to the Factory. Recommended key sizes for the listed maximum bores are shown in **Table 35, page 52**.

⑤ Minimum bore is the smallest bore to which a Rough Stock Bore (RSB) hub can be bored. Depending upon coupling size, RSB hubs may have only a blind centering hole or a through hole that will permit remachining of the hubs to the minimum bores specified.

# Type GC05 Continuous Sleeve Single Engagement

## Floating Shaft

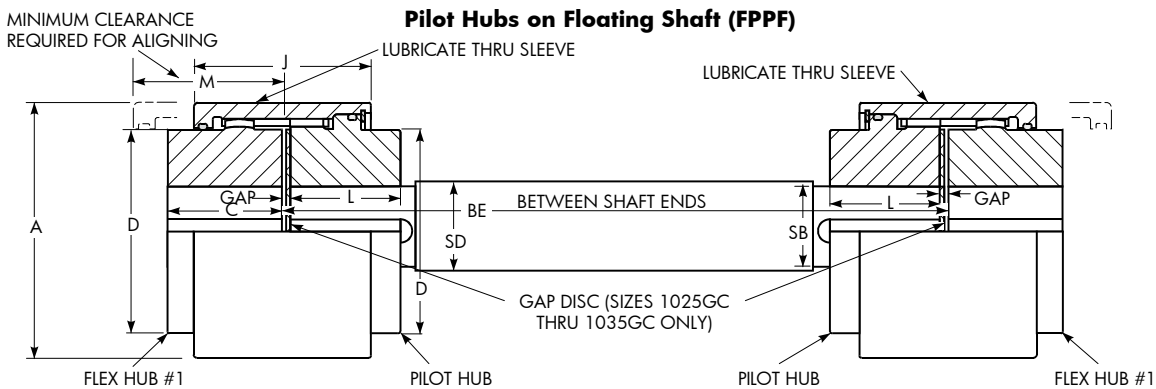
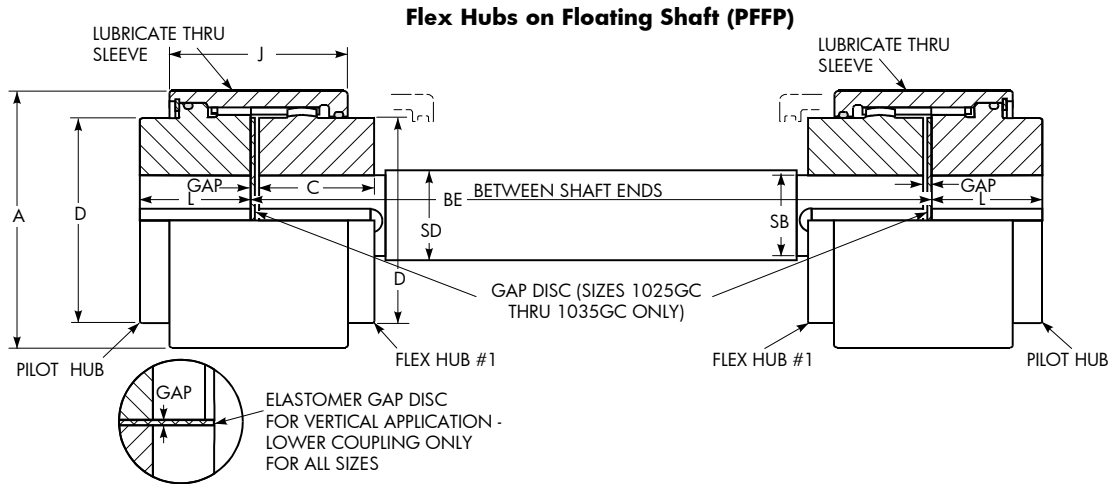

### Dimensions (mm)

Size ①	Torque Rating (Nm) ②	Allow Speed RPM ③	Max Bore (mm) ④	Min Bore ⑤	Cplg Wt each w/o Bore (kg)	Lube Wt (kg)	A	BE Min		C	D	J	L	M	GAP
								PFFP	FPPF						
1010GC	1 140	5300	50	12,7	3,49	0,00850	88,9	190	92,2	42,9	68,6	61,2	42,9	65	3
1015GC	2 350	4300	65	19,0	6,40	0,0198	109,2	235	104,9	49,3	86,4	76,2	51,1	81	3
1020GC	4 270	3700	78	25,4	11,7	0,0312	132,1	290	130,3	62,0	105,2	94,5	63,8	99	3
1025GC	7 470	3300	98	31,8	21,8	0,0522	163,6	338	163,6	77,0	130,6	109,1	77,0	116	5
1030GC	12 100	2900	111	38,1	34,6	0,0730	190,5	368	192,0	91,2	152,4	119,9	91,2	126	5
1035GC	18 500	2600	134	50,8	52,2	0,0957	215,9	413	225,6	106,4	177,8	133,5	106,4	140	6

### Floating Shaft

Size ①	Assembly Torque Rating (Nm) ②	SB Shaft End Dia (mm)	SD Shaft Dia (mm)	Weight (kg per mm)	WR <sup>2</sup> (KgM <sup>2</sup> per mm)	Floating Shafts (mm) Max BE (mm) for Various RPMs ③						
						1750	1430	1170	870	720	580	540 & Less
1010GC	439	38,1	39,7	0,00964	0,0000196	1 371	1 524	1 676	1 955	2 159	2 387	2 463
	1 140	47,6	50,8	0,0159	0,00000518	1 549	1 727	1 905	2 209	2 438	2 717	2 794
1015GC	1 169	50,8	54,0	0,0179	0,00000657	1 600	1 778	1 955	2 286	2 514	2 794	2 870
	2 350	60,3	63,5	0,0248	0,0000126	1 752	1 930	2 133	2 463	2 717	3 022	3 124
1020GC	2 282	63,5	66,7	0,0273	0,0000152	1 778	1 981	2 184	2 540	2 794	3 098	3 200
	4 270	73,0	76,2	0,0357	0,0000259	1 905	2 108	2 336	2 717	2 971	3 237	3 429
1025GC	4 463	79,4	82,6	0,0420	0,0000357	1 981	2 209	2 438	2 819	3 098	3 454	3 556
	7 470	92,1	95,2	0,0559	0,0000634	2 133	2 362	2 616	3 022	3 327	3 708	3 835
1030GC	8 508	98,4	101,6	0,0636	0,0000820	2 209	2 438	2 692	3 124	3 454	3 835	3 962
	12 100	104,8	108,0	0,0718	0,000104	2 260	2 514	2 794	3 225	3 556	3 962	4 064
1035GC	13 333	114,3	120,6	0,0896	0,000163	2 413	2 667	2 946	3 403	3 759	4 191	4 292
	18 500	123,8	127,0	0,0993	0,000200	2 463	2 717	3 022	3 505	3 860	4 292	4 419

① See page 11 for General Information.

② Limited by coupling size, shaft end diameter or both. Refer to page 18 for selection procedure.

③ Interpolate for intermediate speeds. Maximum BE is based on 70% of critical speed. Refer to the Factory for higher running speeds.

④ Maximum bores are reduced for hubs furnished with an interference fit and a setscrew over the keyway. Maximum bores may also be reduced when puller bolt holes are required. Refer to Table 13 and Table 14, page 43. Bore capacities can be increased beyond values shown if the coupling torque rating is reduced. Refer to the Factory. Recommended key sizes for the listed maximum bores are shown in Table 35, page 52.

⑤ Minimum bore is the smallest bore to which a Rough Stock Bore (RSB) hub can be bored. Depending upon coupling size, RSB hubs may have only a blind centering hole or a through hole that will permit remachining of the hubs to the minimum bores specified.

# Type G20 Standard Flanged Sleeve Double Engagement

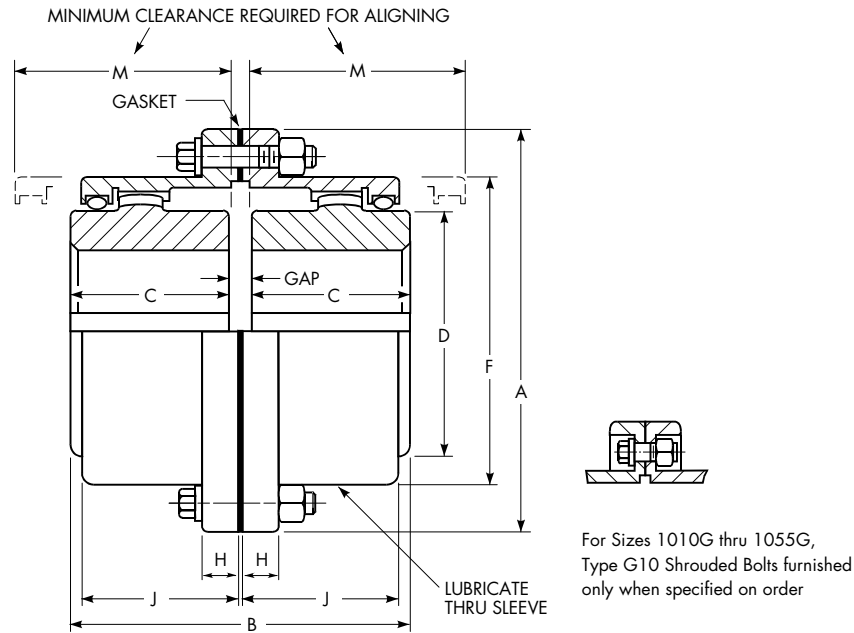

## Dimensions (mm)

Size ①	Torque Rating (Nm) ④	Allow Speed RPM ⑤	Max Bore ⑥	Min Bore ⑦	Cplg Wt With No Bore (kg)		Lube Wt (kg)	A	B	C	D	F	H	J	M	GAP
					G10	G20										
1010G	1 140	8000	50	13	4,08	4,54	0,0408	115,9	88,9	42,9	68,6	83,8	14,0	38,9	51	3
1015G	2 350	6500	65	20	7,71	9,07	0,0726	152,40	101,6	49,3	86,4	105,2	19,0	47,8	61	3
1020G	4 270	5600	78	26	13,6	15,9	0,113	177,80	127,0	62,0	105,2	126,5	19,0	59,4	77	3
1025G	7 470	5000	98	32	24,9	29,5	0,2127	212,70	158,9	77,0	130,6	154,9	21,8	71,6	92	5
1030G	12 100	4400	111	39	38,6	43,1	0,363	239,70	187,4	91,2	152,4	180,3	21,8	83,8	107	5
1035G	18 500	3900	134	51	61,2	68,0	0,544	279,40	218,9	106,4	177,8	211,3	28,4	97,5	130	6
1040G	30 600	3600	160	64	88,5	97,5	0,907	317,50	247,3	120,6	209,6	245,4	28,4	111,3	145	6
1045G	42 000	3200	183	77	127	136	1,04	346,10	277,7	134,9	235,0	274,1	28,4	122,9	166	8
1050G	56 600	2900	200	89	177	191	1,77	388,90	314,3	153,2	254,0	305,8	38,1	140,7	183	8
1055G	74 000	2650	220	102	238	249	2,22	425,40	344,3	168,1	279,4	334,3	38,1	158,0	204	8
1060G	90 400	2450	244	115	—	306	3,18	457,20	384,4	188,2	304,8	366,0	25,4	169,2	229	8
1070G	135 000	2150	289	127	—	485	4,35	527,0	451,5	220,7	355,6	424,9	28,4	195,6	267	10

Table 7 — Limited End Float & Standard Gap Disc Dimensions (mm)

Size	B	End Float ②	Gap Disc ③		GAP
			Thickness	Dia	
1010G	90,9	2,39	4	75	5
1015G	103,6	2,39	4	94	5
1020G	129,8	2,39	5	114	6
1025G	162,3	2,39	7	141	8
1030G	191,5	2,39	8	165	9
1035G	223,3	4,78	8	192	10
1040G	251,7	4,78	8	227	10
1045G	283,2	4,78	11	253	13
1050G	319,8	4,78	11	278	13
1055G	350,5	4,78	12	305	14
1060G	392,4	4,78	14	333	16
1070G	459,7	4,78	16	384	18

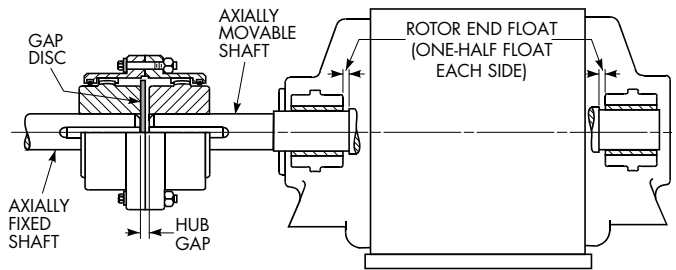

- ① See page 11 for General Information.
- ② If these values exceed one-half rotor end float or equivalent manufacturer's specification, refer to the Factory.
- ③ Gap disc material: Neoprene, 70 durometer.
- ④ Peak torque capacity is two times the published rating.
- ⑤ Consult Factory for higher speeds. Balancing may allow up to a 50% increase in speeds shown. Consult Factory or I & M manual for min. speeds with LTG NLGI1 greases.
- ⑥ Maximum bores are reduced for hubs furnished with an interference fit and a setscrew over the keyway. Maximum bores may also be reduced when puller bolt holes are required. Refer to Table 13 and Table 14, page 43. Bore capacities can be increased beyond values shown if the coupling torque rating is reduced. Refer to the Factory. Recommended key sizes for the listed maximum bores are shown in Table 35, page 52, and Table 23, page 47.
- ⑦ Minimum bore is the smallest bore to which a Rough Stock Bore (RSB) hub can be bored. Depending upon coupling size, RSB hubs may have only a blind centering hole or a through hole that will permit remachining of the hubs to the minimum bores specified.

# Type G32 Standard Flanged Sleeve Spacer

## Without Limited End Float

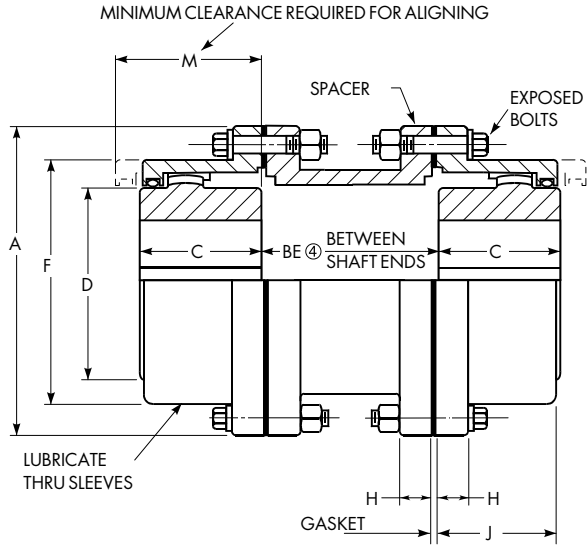

### Dimensions (mm)

Size	End Float ①	SG	Addition to Stock BE Length ②
1015G	2,4	0,5969	2,2
1020G	2,4	0,5969	2,7
1025G	2,4	0,5969	3,7
1030G	2,4	0,5969	4,7
1035G	4,8	1,19	4,7
1040G thru 1070G	4,8	1,19	None

Size	Standard BE Spacers				
	89	111	114	127	178
1010G	X	X	—	X	—
1015G	—	—	—	X	—
1020G	—	X	—	X	X
1025G	—	—	—	X	X
1030G	—	—	—	X	X
1035G	—	—	X ⑨	—	—

## With Limited End Float

(Refer to drawing at left for balance of dimensions.)

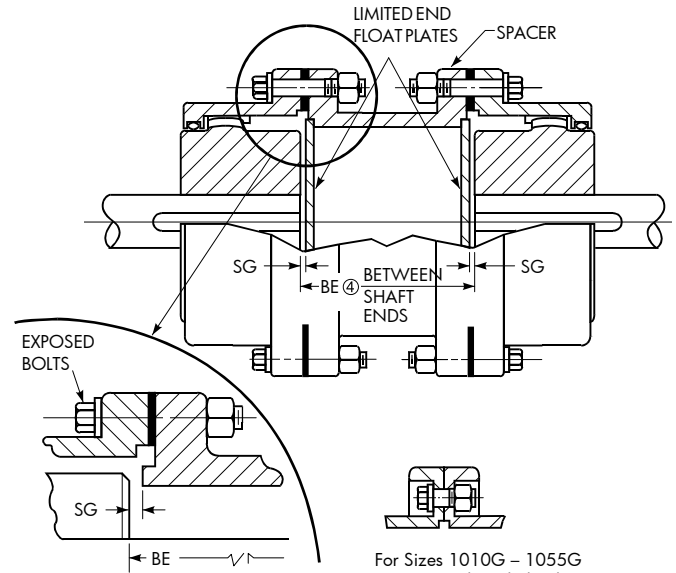

NON-STOCK SPACER DESIGN  
SIZES 1010 THRU 1070G32.

For Sizes 1010G – 1055G  
Type G31 Shrouded Bolts  
furnished only when  
specified on order.

### Dimensions (mm)

Size ③	Torque Rating (Nm) ⑤	Allow Speed RPM ⑥	Max Bore ⑦	Min Bore ⑧	Coupling Wt (kg)		Lube Wt (kg)		A	BE Min ④		C	D	F	H	J	M
					Cplg Wt with No Bore and Min BE	Extra Spacer Wt per mm of Length	Min Wt Less Spacer	Plus per mm of Spacer Length		G31	G32						
1010G	1 140	7000	50	13	6,80	0,0120	0,0408	—	115,9	82	82	42,9	68,6	83,8	14,0	38,9	51
1015G	2 350	5500	65	20	13,6	0,0127	0,0726	—	152,4	82	82	49,3	86,4	105,2	19,0	47,8	61
1020G	4 270	4600	78	26	20,4	0,0166	0,113	0,000536	177,8	82	82	62,0	105,2	126,5	19,0	59,4	77
1025G	7 470	4000	98	32	38,6	0,0205	0,227	0,00107	212,7	108	95	77,0	130,6	154,9	21,8	71,6	92
1030G	12 100	3600	111	39	54,4	0,0236	0,363	0,00107	239,7	108	95	91,2	152,4	180,3	21,8	83,8	107
1035G	18 500	3100	134	51	88,5	0,0359	0,544	0,00214	279,4	130	120	106,4	177,8	211,3	28,4	97,5	130
1040G	30 600	2800	160	64	122,5	0,0500	0,907	0,00357	317,5	130	120	120,6	209,6	245,4	28,4	111,3	145
1045G	42 000	2600	183	77	166	0,0736	1,04	0,00357	346,1	130	120	134,9	235,0	274,1	28,4	122,9	166
1050G	56 600	2400	200	89	238	0,0814	1,77	0,00357	388,9	184	146	153,2	254,0	305,8	38,1	140,7	183
1055G	74 000	2200	220	102	306	0,0895	2,22	0,00357	425,4	184	146	168,1	279,4	334,3	38,1	158,0	204
1060G	90 400	2100	244	115	358	0,117	3,18	0,00357	457,2	—	146	188,2	304,8	366,0	25,4	169,2	229
1070G	135 000	1800	289	127	562	0,141	4,35	0,00357	527,0	—	146	220,7	355,6	424,9	28,4	195,6	267

- ① Refer to the Factory if these values exceed one-half the rotor end float or the equipment manufacturer's specifications.
- ② Couplings with stock spacers and limited end float must add applicable addition to the BE (Between Shaft Ends) dimension.
- ③ See **page 11** for General Information.
- ④ BE is the distance between shaft ends whether standard (stock) or special spacer lengths are used.
- ⑤ Peak torque capacity is two times the published rating.
- ⑥ Consult Factory for higher speeds. Balancing may allow up to a 50% increase in speeds shown.
- ⑦ Maximum bores are reduced for hubs furnished with an interference fit and a setscrew over the keyway. Maximum bores may also be reduced when puller bolt holes are required. Refer to **Table 13 and Table 14, page 43**. Bore capacities can be increased beyond values shown if the coupling torque rating is reduced. Refer to the Factory. Recommended key sizes for the listed maximum bores are shown in **Table 35, page 52**, and **Table 23, page 47**.
- ⑧ Minimum bore is the smallest bore to which a Rough Stock Bore (RSB) hub can be bored. Depending upon coupling size, RSB hubs may have only a blind centering hole or a through hole that will permit remachining of the hubs to the minimum bores specified.
- ⑨ Bolt holes staggered for assembly clearance.

# Type G52 Standard Flanged Sleeve Single Engagement

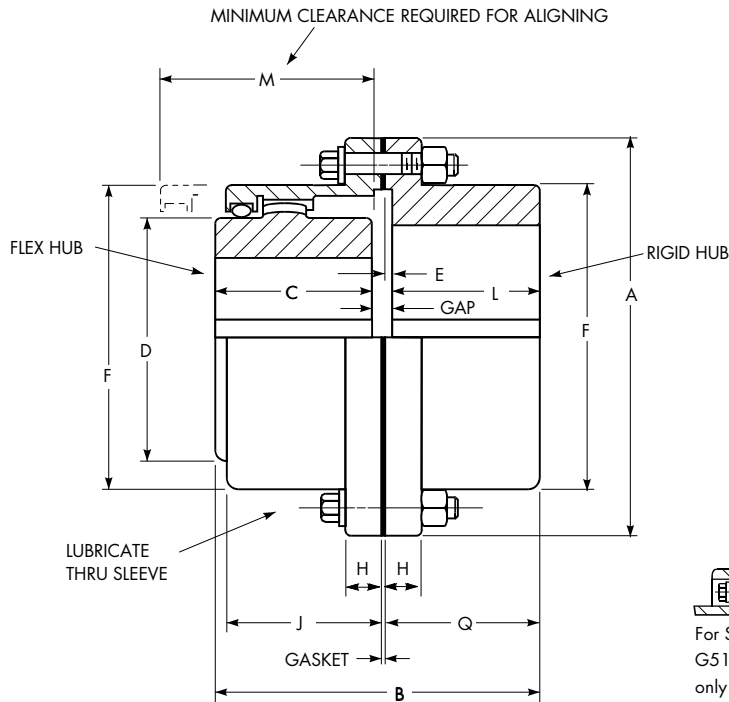

For Sizes 1010G thru 1055G, Type G51 Shrouded Bolts furnished only when specified on order.

## Dimensions (mm)

Size ①	Torque Rating (Nm) ②	Allow Speed RPM ③	Max Bore ④		Min Bore ⑤	Cplg Wt with No Bore (kg)		Lube Wt (kg)	A	B	C	D	E	F	H	J	L	M	Q	GAP
			Flex Hub	Rigid Hub		G51	G52													
1010G	1 140	8000	50	65	13	4,08	4,54	0,0227	115,9	86,6	42,9	68,6	2,5	83,8	14,0	38,9	39,6	51	42,2	4
1015G	2 350	6500	65	80	20	8,16	9,07	0,0408	152,4	99,6	49,3	86,4	2,5	105,2	19,0	47,8	46,2	61	48,8	4
1020G	4 270	5600	78	98	26	13,6	15,9	0,0680	177,8	124,5	62,0	105,2	2,5	126,5	19,0	59,4	58,4	76	61,0	4
1025G	7 470	5000	98	118	32	24,9	27,2	0,118	212,7	155,4	77,0	130,6	2,5	154,9	21,8	71,6	73,7	91	76,2	5
1030G	12 100	4400	111	140	39	38,6	43,1	0,181	239,7	183,9	91,2	152,4	2,5	180,3	21,8	83,8	87,9	107	90,4	5
1035G	18 500	3900	134	163	51	61,2	68,0	0,272	279,4	214,1	106,4	177,8	2,5	211,3	28,4	97,5	102,1	130	104,6	6
1040G	30 600	3600	160	196	64	90,7	99,8	0,467	317,5	242,8	120,6	209,6	4,1	245,4	28,4	111,3	115,3	145	119,4	7
1045G	42 000	3200	183	216	77	129,3	136	0,557	346,1	273,1	134,9	235,0	4,1	274,1	28,4	122,9	130,6	165	134,6	8
1050G	56 600	2900	200	235	89	181,4	195	0,907	388,9	309,1	153,2	254,0	5,1	305,8	38,1	140,7	147,3	183	152,4	9
1055G	74 000	2650	220	266	102	251,7	263	1,13	425,4	349,5	168,1	279,4	5,1	334,3	38,1	158,0	172,7	203	177,8	9
1060G	90 400	2450	244	290	115	—	324	1,70	457,2	385,1	188,2	304,8	6,6	366,0	25,4	169,2	186,4	229	193,0	10
1070G	135 000	2150	289	340	127	—	508	2,27	527,0	453,6	220,7	355,6	8,4	424,9	28,4	195,6	220,2	267	228,6	13

① See page 11 for General Information.

② Peak torque capacity is two times the published rating.

③ Consult Factory for higher speeds. Balancing may allow up to a 50% increase in speeds shown.

④ Maximum bores are reduced for hubs furnished with an interference fit and a setscrew over the keyway. Maximum bores may also be reduced when puller bolt holes are required. Refer to Table 13 and Table 14, page 43. Bore capacities can be increased beyond values shown if the coupling torque rating is reduced. Refer to the Factory. Recommended key sizes for the listed maximum bores are shown in Table 35, page 52, and Table 23, page 47.

⑤ Minimum bore is the smallest bore to which a Rough Stock Bore (RSB) hub can be bored. Depending upon coupling size, RSB hubs may have only a blind centering hole or a through hole that will permit remachining of the hubs to the minimum bores specified.

# Type G52 Standard Flanged Sleeve Single Engagement

## Floating Shaft/Dimensions (mm)

A standard floating shaft assembly consists of two standard single engagement couplings, two gap discs and a connecting shaft.

A floating shaft can eliminate the need for additional bearing supports along spanning shafts, because shaft is supported at ends by connected equipment through the single engagement couplings.

### Flex Hubs on Floating Shaft (RFFR)

Assembly of the flex hubs on the floating shaft allows for easier replacement in case of wear and allows the rigid hubs with their increased bore capacity to be used on the connected equipment shafts. This frequently means a smaller coupling size can be used.

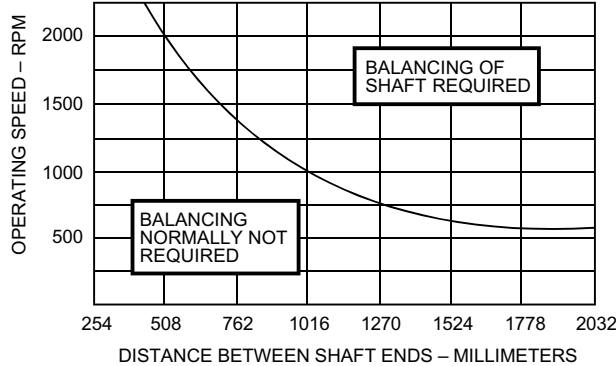

### Rigid Hubs on Floating Shaft (FRRF)

When the rigid hubs are on the floating shaft, shorter shaft spans can be accommodated, since no cover drawback is required. Since the flex hubs are outboard, the points of articulation are further apart, providing greater offset misalignment capacity.

### Solid Floating Shaft Selection

Single Engagement Type G52/GV52 couplings are used with floating shafts in either horizontal or vertical applications. For vertical applications, select a Type GV coupling for the lower coupling assembly. Select floating shafts as follows:

1. Use the Standard or Formula Selection Methods, **pages 6 and 7** to select the couplings. Record the System Torque from standard selection method or Selection Torque from formula selection method.
2. From the table below, select a shaft diameter that has an assembly torque rating equal to or greater than the system or selection torque determined in coupling selection.
3. Check maximum "BE" for the shaft diameter selected and running speed for the shaft length required from the table below. Refer to the graph at left to determine if the shaft requires balancing.
4. If the application shaft length exceeds the maximum "BE" listed, select the next larger shaft diameter or the next larger size coupling. Consult the Factory for higher speeds or longer shaft lengths than listed below.

## Floating Shaft — Millimeters (mm)

Size ①	Assembly Torque Rating (Nm) ②	SB Shaft End Diameter	SD Shaft Diameter	Weight (kg) per mm	WR <sup>2</sup> (kgm <sup>2</sup> ) per mm	Maximum BE for Various RPMs ③						
						1750	1430	1170	870	720	580	540 & Less
1010G	493	38,1	39,7	0,00964	0,00000196	1 371	1 524	1 676	1 955	2 159	2 387	2 463
	1 140	47,6	50,8	0,0159	0,00000518	1 549	1 727	1 905	2 209	2 438	2 717	2 794
1015G	1 169	50,8	54,0	0,0179	0,00000657	1 600	1 778	1 955	2 286	2 514	2 794	2 870
	2 350	60,3	63,5	0,0248	0,0000126	1 752	1 930	2 133	2 463	2 717	3 022	3 124
1020G	2 282	63,5	66,7	0,0273	0,0000152	1 778	1 981	2 184	2 540	2 794	3 098	3 200
	4 270	73,0	76,2	0,0557	0,0000259	1 905	2 108	2 336	2 717	2 971	3 327	3 429
1025G	4 463	79,4	82,6	0,0420	0,0000357	1 981	2 209	2 438	2 819	3 098	3 454	3 556
	7 470	92,1	95,2	0,0559	0,0000634	2 133	2 362	2 616	3 022	3 237	3 708	3 835
1030G	8 508	98,4	101,6	0,0636	0,0000820	2 209	2 438	2 692	3 124	3 454	3 835	3 962
	12 100	104,8	108,0	0,0718	0,000104	2 260	2 514	2 794	3 225	3 556	3 962	4 064
1035G	13 333	114,3	120,6	0,0896	0,000163	2 413	2 667	2 946	3 403	3 759	4 191	4 292
	18 500	123,8	127,0	0,993	0,000200	2 463	2 717	3 022	3 505	3 860	4 292	4 419
1040G	24 327	139,7	146,0	0,131	0,000350	2 641	2 921	3 251	3 759	4 140	4 597	4 749
	30 600	146,0	152,4	0,143	0,000415	2 692	2 997	3 302	3 835	4 216	4 699	4 851
1045G	31 581	152,4	165,1	0,168	0,000572	2 819	3 124	3 454	3 987	4 394	4 902	5 029
	42 000	171,5	203,2	0,254	0,00131	3 124	3 454	3 810	4 445	4 876	5 435	5 588
1050G	37 886	161,9	165,1	0,168	0,000572	2 819	3 124	3 454	3 987	4 394	4 902	5 029
	56 600	187,3	203,2	0,254	0,00131	3 124	3 454	3 810	4 445	4 876	5 435	5 588
1055G	37 886	161,9	165,1	0,168	0,000572	2 819	3 124	3 454	3 987	4 394	4 902	5 029
	74 000	200,0	203,2	0,254	0,00131	3 124	3 454	3 810	4 445	4 876	5 435	5 588
1060G	71 410	200,0	203,2	0,254	0,00131	3 124	3 454	3 810	4 445	4 876	5 435	5 588
	90 400	215,9	217,4	0,291	0,00172	3 225	3 581	3 962	4 597	5 054	5 613	5 791
1070G	71 410	200,0	203,2	0,254	0,00131	3 124	3 454	3 810	4 445	4 876	5 435	5 588
	135 000	241,3	242,8	0,363	0,00268	3 403	3 784	4 191	4 851	5 334	5 943	6 121

① See **page 11** for General Information.

② Assembly torque rating is limited by coupling size, shaft end diameter or both.

③ Interpolate for intermediate speeds. Maximum BE is based on 70% of critical speed. Refer to the Factory for higher running speeds.

# Type G52 Standard Flanged Sleeve Single Engagement

## Floating Shaft

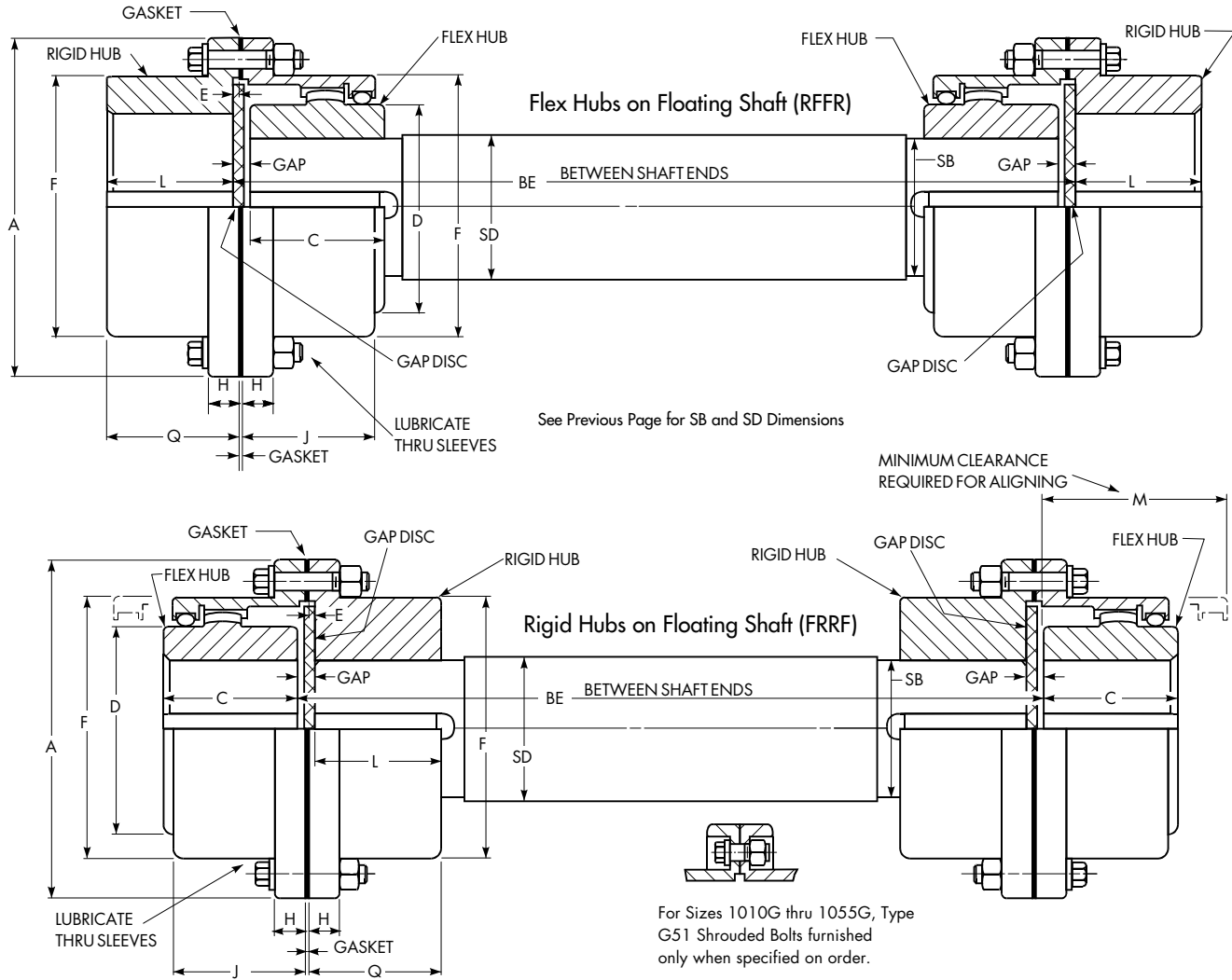

## Dimensions (mm)

Size ①	Max Bore ②		Min Bore ③	Wt—One Cplg No Bore (kg)		Lube Wt per Cplg (kg)	A	BE Min		C	D	E	F	H	J	L	M	Q	GAP
	Flex Hub	Rigid Hub		RFFR	FRRF														
1010G	50	65	13	4,08	4,54	0,0227	115,9	133	92	42,9	68,6	2,5	83,8	14,0	38,9	39,6	48	42,2	4
1015G	65	80	20	8,16	9,07	0,0408	152,4	159	105	49,3	86,4	2,5	105,2	19,0	47,8	46,2	56	48,8	4
1020G	78	98	26	13,6	15,9	0,0680	177,8	197	129	62,0	105,2	2,5	126,5	19,0	59,4	58,4	69	61,0	4
1025G	98	118	32	24,9	27,2	0,118	212,7	241	162	77,0	130,6	2,5	154,9	21,8	71,6	73,7	81	76,2	5
1030G	111	140	39	38,6	43,1	0,181	239,7	279	189	91,2	152,4	2,5	180,3	21,8	83,8	87,9	94	90,4	5
1035G	134	163	51	61,2	68,0	0,272	279,4	324	219	106,4	177,8	2,5	211,3	28,4	97,5	102,1	107	104,6	6
1040G	160	196	64	90,7	99,8	0,467	317,5	419	248	120,6	209,6	4,1	245,4	28,4	111,3	115,3	122	119,4	7
1045G	183	216	77	129,3	136	0,557	346,1	508	281	134,9	235,0	4,1	274,1	28,4	122,9	130,8	135	134,6	8
1050G	200	235	89	181,4	195	0,907	388,9	533	316	153,2	254,0	5,1	305,8	38,1	140,7	147,3	152	152,4	9
1055G	220	266	102	251,7	263	1,13	425,4	572	367	168,1	279,4	5,1	334,3	38,1	158,0	172,7	173	177,8	9
1060G	244	290	115	—	324	1,70	457,2	597	397	188,2	304,8	6,6	366,0	25,4	169,2	186,4	183	193,0	10
1070G	289	340	127	—	508	2,27	527,0	673	470	220,7	355,6	8,4	424,9	28,4	195,6	220,2	208	228,6	13

① See page 11 for General Information.

② Maximum bores are reduced for hubs furnished with an interference fit and a setscrew over the keyway. Maximum bores may also be reduced when puller bolt holes are required. Refer to Table 13 and Table 14, page 43. Bore capacities can be increased beyond values shown if the coupling torque rating is reduced. Refer to the Factory. Recommended key sizes for the listed maximum bores are shown in Table 35, page 52, and Table 23, page 47.

③ Minimum bore is the smallest bore to which a Rough Stock Bore (RSB) hub can be bored. Depending upon coupling size, RSB hubs may have only a blind centering hole or a through hole that will permit remachining of the hubs to the minimum bores specified.

# Type GV20 Standard Flanged Sleeve Vertical Double Engagement

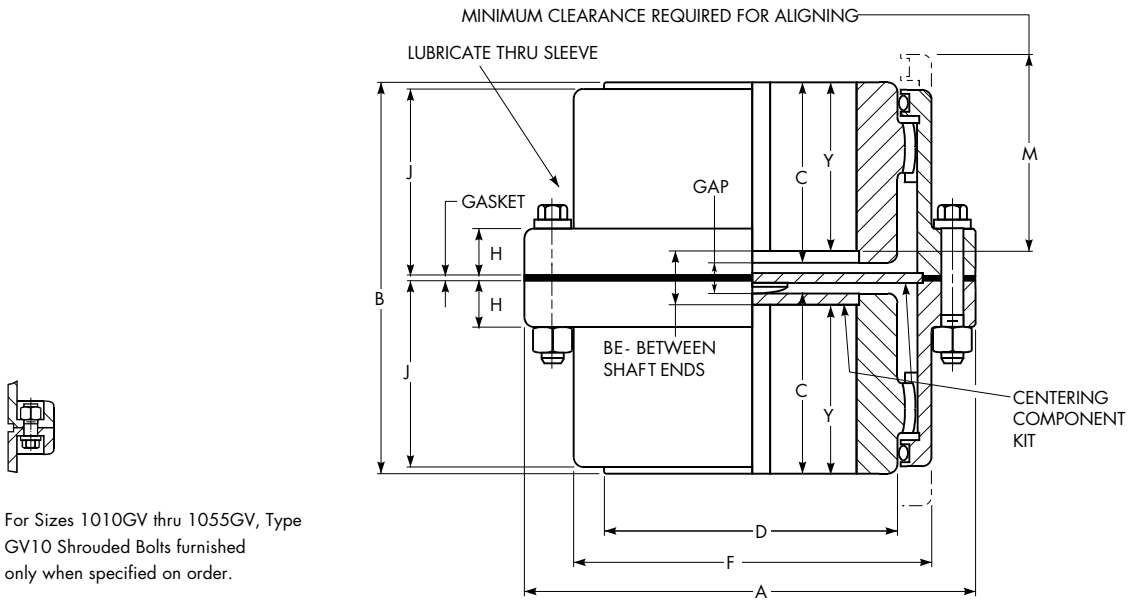

## Dimensions (mm)

Size ①	Torque Rating (Nm) ②	Allow Speed RPM ③	Max Bore ④	Min Bore ⑤	Cplg Wt with No Bore (kg)		Lube Wt (kg)	A	B	C	D	F	H	J	M	Y	BE	GAP
					GV10	GV20												
1010GV	1 140	8000	50	13	3,63	4,08	0,0816	115,9	88,9	38,9	68,6	83,8	14,0	38,9	46	32,5	23,9	11
1015GV	2 350	6500	65	20	7,71	8,62	0,136	152,40	101,1	45,0	86,4	105,2	19,0	47,8	56	38,6	23,9	11
1020GV	4 270	5600	78	26	13,6	14,5	0,227	177,80	126,5	57,7	105,2	126,5	19,0	59,4	71	51,3	23,9	11
1025GV	7 470	5000	98	32	23,6	26,3	0,408	212,70	157,5	71,6	130,6	154,9	21,8	71,6	86	65,3	26,9	14
1030GV	12 100	4400	111	39	36,3	40,8	0,635	239,70	186,4	86,1	152,4	180,3	21,8	83,8	102	79,8	26,9	14
1035GV	18 500	3900	134	51	59,0	65,8	0,998	279,40	217,2	100,3	177,8	211,3	28,4	97,5	125	94,0	30,2	18
1040GV	30 600	3600	160	64	88,4	97,5	1,45	317,50	246,9	112,3	209,6	245,4	28,4	111,3	140	105,9	35,1	22
1045GV	42 000	3200	183	77	123	132	2,00	346,10	276,9	125,7	235,0	274,1	28,4	122,9	158	116,3	44,2	25
1050GV	56 600	2900	200	89	172	186	2,86	388,90	313,4	144,0	254,0	305,8	38,1	140,7	175	134,6	44,2	25
1055GV	74 000	2650	220	102	231	243	3,62	425,40	343,4	159,0	279,4	334,3	38,1	158,0	196	149,6	44,2	25
1060GV	90 400	2450	244	115	—	302	4,81	457,20	384,0	177,8	304,8	366,0	25,4	169,2	221	168,1	47,8	29
1070GV	135 000	2150	289	127	—	476	7,08	527,0	450,6	207,8	355,6	424,9	28,4	195,6	254	194,8	61,0	35

① See page 11 for General Information.

② Peak torque capacity is two times the published rating.

③ Consult Factory for higher speeds. Balancing may allow up to a 50% increase in speeds shown.

④ Maximum bores are reduced for hubs furnished with an interference fit and a setscrew over the keyway. Maximum bores may also be reduced when puller bolt holes are required. Refer to Table 13 and Table 14, page 43. Bore capacities can be increased beyond values shown if the coupling torque rating is reduced. Refer to the Factory. Recommended key sizes for the listed maximum bores are shown in Table 35, page 52, and Table 23, page 47.

⑤ Minimum bore is the smallest bore to which a Rough Stock Bore (RSB) hub can be bored. Depending upon coupling size, RSB hubs may have only a blind centering hole or a through hole that will permit remachining of the hubs to the minimum bores specified.

# Type GV52 Standard Flanged Sleeve Vertical Single Engagement

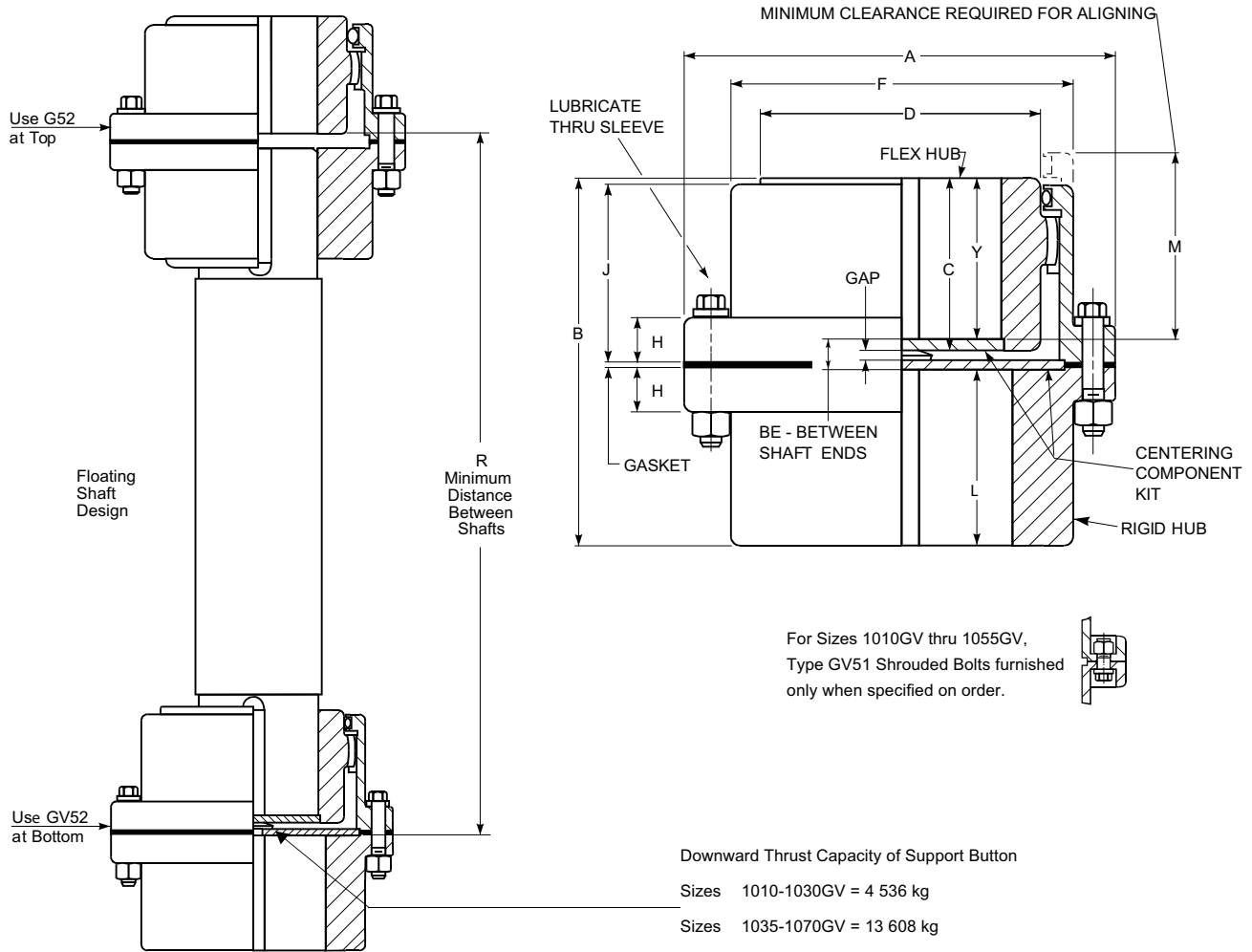

## Dimensions (mm)

Size ①	Torque Rating (Nm) ②④	Allow Speed RPM ③	Max Bore ⑤		Min Bore ⑥	Wt One Cplg with No Bore (kg)		Lube Wt (kg)	A	B	C	D	F	H	J	L	M	R	Y	BE	GAP
			Flex Hub	Rigid Hub		GV51	GV52														
1010GV	1 140	7000	50	65	13	4,08	4,54	0,0363	115,9	86,9	38,9	68,6	83,8	14,0	38,9	39,6	45,7	131,6	32,5	14,7	4
1015GV	2 350	5500	65	80	20	8,16	9,07	0,0544	152,40	99,6	45,0	86,4	105,2	19,0	47,8	46,2	55,9	152,4	38,6	14,7	4
1020GV	4 270	4600	78	98	26	13,6	15,9	0,0907	177,80	124,5	57,7	105,2	126,5	19,0	59,4	58,4	71,1	182,9	51,3	14,7	4
1025GV	7 470	4000	98	118	32	24,9	27,2	0,1814	212,70	155,2	71,6	130,6	154,9	21,8	71,6	73,7	86,4	217,7	65,3	16,3	5
1030GV	12 100	3600	111	140	39	38,6	43,1	0,2722	239,70	183,9	86,1	152,4	180,3	21,8	83,8	87,9	101,6	247,7	79,8	16,3	5
1035GV	18 500	3100	134	163	51	61,2	68,0	0,4536	279,40	214,1	100,3	177,8	211,3	28,4	97,5	102,1	124,5	297,9	94,0	18,0	7
1040GV	30 600	2800	160	196	64	88,5	102	0,6804	317,50	243,3	112,3	209,6	245,4	28,4	111,3	115,3	139,7	340,4	105,9	22,0	8
1045GV	42 000	2600	183	216	77	129,3	138	0,9072	346,10	273,6	125,7	235,0	274,1	28,4	122,9	130,6	157,5	388,1	116,3	26,7	9
1050GV	56 600	2400	200	235	89	181,4	197	1,36	388,90	309,6	144,0	254,0	305,8	38,1	140,7	147,3	175,3	423,7	134,6	27,7	8
1055GV	74 000	2200	220	266	102	251,7	265	1,68	425,40	350,0	159,0	279,4	334,3	38,1	158,0	172,7	195,6	464,3	149,6	27,7	8
1060GV	90 400	2100	244	290	115	-	390	2,27	457,20	385,6	177,8	304,8	366,0	25,4	169,2	186,4	221,0	522,2	168,1	30,9	8
1070GV	135 000	1800	289	340	127	-	517	3,27	527,0	454,2	207,8	355,6	424,9	28,4	195,6	220,2	254,0	615,2	194,8	39,1	10

① See page 11 for General Information.

② Torque Rating is for coupling only, refer to page 18 for floating shaft selection and ratings.

③ Allowable speed listed is for GV52 coupling only, refer to page 18 for floating shaft selection and running speed.

④ Peak torque capacity is two times the published rating.

⑤ Maximum bores are reduced for hubs furnished with an interference fit and a setscrew over the keyway. Maximum bores may also be reduced when puller bolt holes are required. Refer to Table 13 and Table 14, page 43. Bore capacities can be increased beyond values shown if the coupling torque rating is reduced. Refer to the Factory. Recommended key sizes for the listed maximum bores are shown in Table 35, page 52, and Table 23, page 47.

⑥ Minimum bore is the smallest bore to which a Rough Stock Bore (RSB) hub can be bored. Depending upon coupling size, RSB hubs may have only a blind centering hole or a through hole that will permit remachining of the hubs to the minimum bores specified.

# Types G62, G63, G66 & G67 Standard Flanged Sleeve Brakewheel/Disc Brake

## Straight Bores — Wheel Sizes 178 mm Diameter & Larger

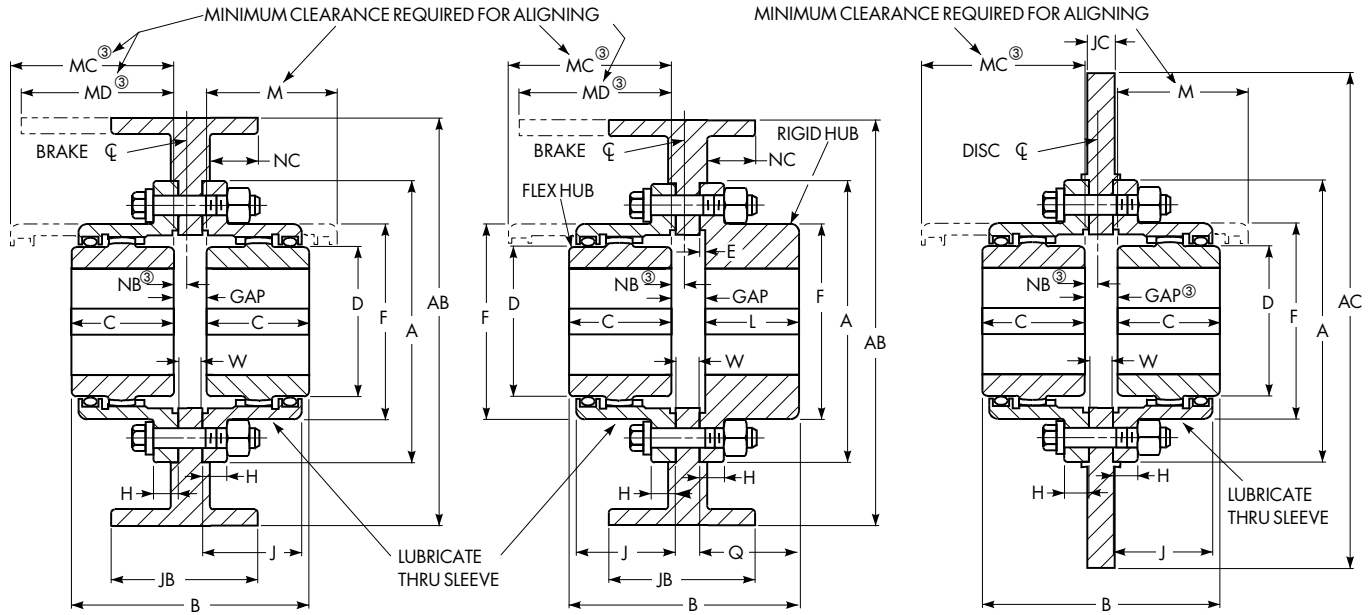

**Double Engagement Type G62**

**Single Engagement Type G66<sup>Ⓣ</sup>**

**Double Engagement Type G63<sup>Ⓣ</sup>**

### Dimensions (mm)

Brake-Wheel Size ②	Cplg Size ①	Brake Rating of Coupling (Nm)	Max Straight Bore ⑤		Min Bore ⑥	Coupling Wt No Bore Less Wheel (kg)			Lube Wt (kg)		B										GAP			
			Flex Hub	Rigid Hub		G62 G63	G66	G62 G63	G66	A	G62 G63	G66 with Std Length Hubs	C	D	E	F	H	J	L	M	Q	W	G62 G63	G66
177,8	1010G	251	50	65	13	4,54	4,54	0,0454	0,0272	115,9	98,6	96,3	42,9	68,6	2,5	83,8	14,0	38,9	39,6	51	42,2	9,7	13	14
203,2	1015G	569	65	80	20	9,07	9,07	0,0907	0,0544	152,40	114,3	112,3	49,3	86,4	2,5	105,2	19,0	47,8	46,2	61	48,8	12,7	16	17
244,3	1020G	1 050	78	98	26	15,9	15,9	0,1361	0,0907	177,80	139,7	137,2	62,0	105,2	2,5	126,5	19,0	59,4	58,4	77	61,0	12,7	16	17
289,0	1025G	1 897	98	118	32	29,5	27,2	0,2722	0,1588	212,70	173,0	169,7	77,0	130,6	2,5	154,9	21,8	71,6	73,7	92	76,2	14,2	19	19
320,5	1030G	3 117	111	140	39	43,1	43,1	0,4082	0,2268	239,70	201,4	198,1	91,2	152,4	2,5	180,3	21,8	83,8	87,9	107	90,4	14,2	19	19
371,3	1035G	4 810	134	163	51	68,0	68,0	0,5670	0,3402	279,40	238,3	233,2	106,4	177,8	2,5	211,3	28,4	97,5	102,1	130	104,6	19,0	25	25
428,7	1040G	7 317	160	196	64	97,5	99,8	0,9072	0,5443	317,50	266,7	261,9	120,6	209,6	4,1	245,4	28,4	111,3	115,3	145	119,4	19,0	25	26
457,2	1045G	10 027	183	216	77	136	136	1,134	0,6350	346,10	296,7	292,1	134,9	235,0	4,1	274,1	28,4	122,9	130,6	166	134,6	19,0	27	27
492,2	1050G	13 550	200	235	89	191	195	1,869	1,134	388,90	339,6	334,5	153,2	254,0	5,1	305,8	38,1	140,7	147,3	183	152,4	25,4	33	34
530,3	1055G	17 784	220	266	102	249	263	2,322	1,361	425,40	369,8	374,9	168,1	279,4	5,1	334,3	38,1	158,0	172,7	204	177,8	25,4	33	34
584,2	1060G	23 035	244	290	115	306	324	3,402	1,928	457,20	408,4	410,5	188,2	304,8	6,6	366,0	25,4	169,2	186,4	229	193,0	25,4	33	36
660,4	1070G	33 469	289	340	127	485	508	4,445	2,608	527,0	476,3	479,0	220,7	355,6	8,4	424,9	28,4	195,6	220,2	267	228,6	25,4	33	38

- ① See page 11 for General Information.
- ② Maximum rim velocity is 6000 feet per minute. Brakewheel must be balanced if peripheral speed exceeds 6000 feet per minute.
- ③ Dimensions and allowable speed vary with application; consult the Factory.
- ④ Dimensions AC and JC depend upon customer caliper specifications.
- ⑤ Maximum bores are reduced for hubs furnished with an interference fit and a setscrew over the keyway. Maximum bores may also be reduced when puller bolt holes are required. Refer to Table 13 and Table 14, page 43. Bore capacities can be increased beyond values shown if the coupling torque rating is reduced. Refer to the Factory. Recommended key sizes for the listed maximum bores are shown in Table 35, page 52, and Table 23, page 47.
- ⑥ Minimum bore is the smallest bore to which a Rough Stock Bore (RSB) hub can be bored. Depending upon coupling size, RSB hubs may have only a blind centering hole or a through hole that will permit remachining of the hubs to the minimum bores specified.
- ⑦ Also available in G67 disc configuration.

# Types G62/G66 Standard Flanged Sleeve Brakewheel (for AISE Brakes)

## Taper Bores — Wheel Sizes 203 – 762 mm Diameter & Larger

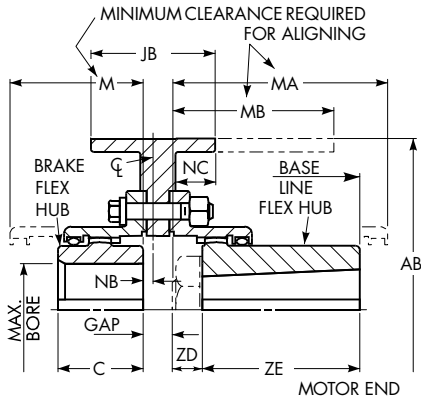

**Double Engagement Type G62  
(One Hub Taper Bored)  
Figure X**

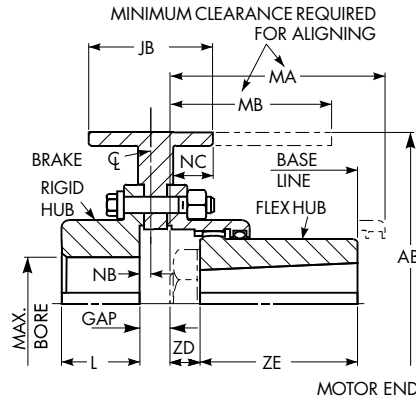

**Single Engagement Type G66  
(Flex Hub Taper Bored)  
Figure Y**

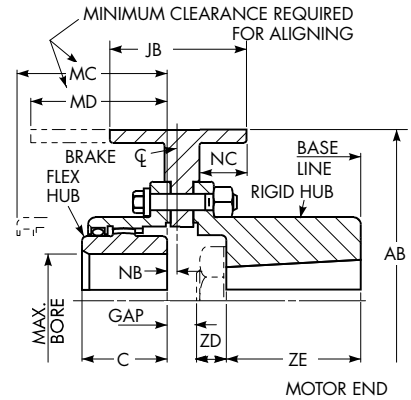

**Single Engagement Type G66  
(Rigid Hub Taper and C' Bored)  
Figure Z**

### Dimensions (mm)

Brake-wheel Dia x Face ②	Part Number	Cplg Size ①	Mill Motor Size	Allow Speed RPM ③	Brake Rating (Nm) ②	Brake Manufacturer & Catalog Number				C	L	M	MA MB Max	MC MD Max	NB		NC	ZD	ZE	GAP	
						C-H Co.	E. C. & M.	G. E.	West						Fig X & Z	Fig Y				Fig X	Fig Y & Z
203,2 x 82,6	10010561	1015G	802	2860	136	8	T-08	A100	TM83	49,3	46,2	61,0	114,3	73,7	14,2	15,5	37,3	23,9	76,2	16	17
254,0 x 95,3	10014459	1015G	803, 804	2290	271	10	T-10	A101	TM1035	49,3	46,2	61,0	127,0	73,7	22,4	23,4	51,6	25,4	88,9	16	17
330,2 x 146,1	10010562	1020G	806	1760	745	13	T-13	A102	TM1355	62,0	58,4	76,2	142,7	88,9	19,1	20,3	73,9	28,7	101,6	16	17
330,2 x 146,1	10010563	1025G	808	1760	745	13	T-13	A102	TM1355	77,0	73,7	91,4	158,8	104,1	28,4	29,0	81,0	31,8	114,3	19	19
406,4 x 171,5	10010564	1025G	810	1430	1 355	16	T-16	A103	TM1665	77,0	73,7	91,4	162,1	119,9	3,0	3,6	68,3	35,1	114,3	19	19
482,6 x 222,3	10014460	1030G	812	1200	2 710	19	T-19	A104	TM1985	91,2	87,9	106,7	177,8	149,4	6,4	5,8 ④	84,1	38,1	127,0	25	19
482,6 x 222,3	10010565	1035G	814	1200	2 710	19	T-19	A104	TM1985	106,4	102,1	129,5	180,3	167,1	3,0	3,0	88,1	41,4	127,0	25	25
584,2 x 285,8	10014461	1040G	816	995	5 420	23	T-23	A105	TM2311	120,6	115,3	144,8	208,3	198,6	0	12,7	116,6	44,5	139,7	33	27
584,2 x 285,8	10014462	1040G	818	995	5 420	23	T-23	A105	TM2311	120,6	115,3	144,8	211,1	209,8	11,2 ④	9,9 ④	105,7	33,3	152,4	33	27
762 x 362	10014463	1050G	820	765	12 195	30	—	—	—	153,2	147,3	182,9	215,9	270,0	11,2 ④	9,4 ④	136,7	44,5	171,5	33	35
762 x 362	10014464	1050G	822	765	12 195	30	—	—	—	153,2	147,3	182,9	244,3	247,9	4,8	6,4	152,4	60,2	184,2	33	35

① See page 11 for General Information.

② For standard AISE brakes.

③ Based on maximum rim velocity of 182,88 meters per minute.

④ Dimension NB and the brakewheel centerline are to the left of the hub face.

## Type GL20 Standard Flanged Sleeve Slide Double Engagement

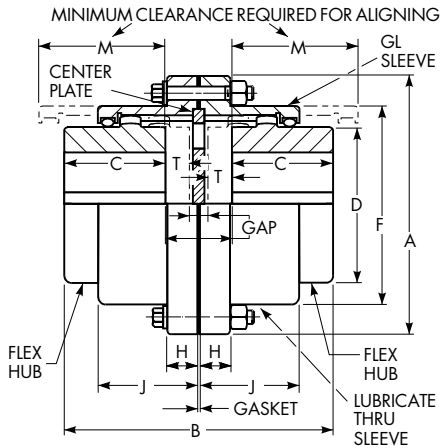

**Type GL20-1**  
Long Tooth Sleeve  
Reversed Std. Hubs  
Center Plate

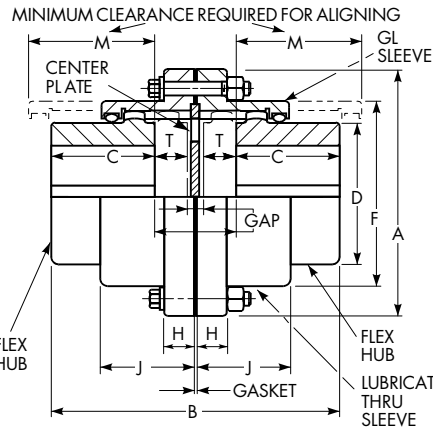

**Type GL20-2**  
Long Tooth Sleeves  
Cutoff Long Hubs  
Center Plate

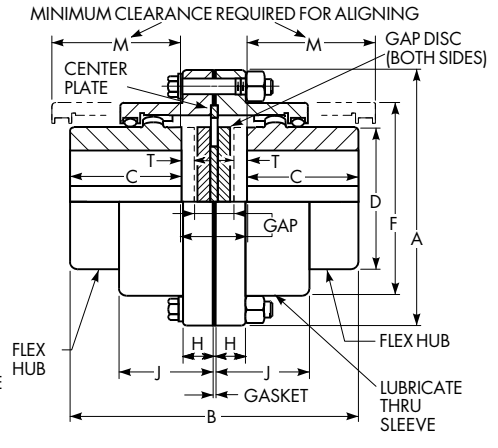

**Type GL20-4**  
Std. Tooth Sleeves  
Reversed Std. Hubs  
Center Plate

### Choosing an Assembly

Select the assembly that provides a Total "T" dimension from the table below equal to the application requirements.

- GL20-1 Moderate slide capacity, moderate price.
- GL20-2 Greatest slide capacity, highest price.
- GL20-4 Least slide capacity, lowest price.

### Dimensions (mm)

Size ①	Torque Rating (Nm) ③	Allow Speed RPM ④	Max Bore ⑤	Min Bore ⑥	Cplg Wt with No Bore (kg)	Lube Wt (kg)	A	C	D	F	H	J
1010GL	1 140	5300	50	13	4,54	0,0227	115,9	42,9	68,6	83,8	14,0	38,9
1015GL	2 350	4300	65	20	9,07	0,0363	152,40	49,3	86,4	105,2	19,0	47,8
1020GL	4 270	3700	78	26	15,9	0,0635	177,80	62,0	105,2	126,5	19,0	59,4
1025GL	7 470	3300	98	32	29,5	0,1134	212,70	77,0	130,6	154,9	21,8	71,6
1030GL	12 100	2900	111	39	40,8	0,1814	239,70	91,2	152,4	180,3	21,8	83,8
1035GL	18 500	2600	134	51	68,0	0,2722	279,40	106,4	177,8	211,3	28,4	97,5
1040GL	30 600	2400	160	64	99,8	0,4536	317,50	120,6	209,6	245,4	28,4	111,3
1045GL	42 000	2100	183	77	136	0,5080	346,10	134,9	235,0	274,1	28,4	122,9
1050GL	56 600	1900	200	89	193	0,9072	388,90	153,2	254,0	305,8	38,1	140,7
1055GL	74 000	1800	220	102	254	0,1314	425,40	168,1	279,4	334,3	38,1	158,0
1060GL	90 400	1600	244	115	318	0,5876	457,20	188,2	304,8	366,0	25,4	169,2
1070GL	135 000	1400	289	127	499	1,1772	527,0	220,7	355,6	424,9	28,4	195,6

Size ①	Type GL20-1						Type GL20-2						Type GL20-4 ②					
	B Max	M	T (Max)		GAP		B Max	M	T (Max)		GAP		B Max	M	T (Max)		GAP	
			Each	Total	Min	Max			Each	Total	Min	Max			Each	Total	Min	Max
1010GL	96,3	53,8	1,27	2,5	8	10	126,2	58,4	16,3	32,5	8	40	96,3	53,8	2,0	4,3	5	10
1015GL	127,3	59,7	10,4	20,8	8	29	152,7	68,6	23,1	46,2	8	54	127,3	59,7	7,4	15,0	14	29
1020GL	150,6	77,2	9,4	18,8	8	27	186,2	83,8	27,2	54,4	8	62	150,6	77,2	9,9	20,1	7	27
1025GL	187,7	93,5	12,2	24,4	9	34	231,4	101,6	34,0	68,1	9	78	187,7	93,5	6,1	12,4	21	34
1030GL	227,3	108,2	17,8	35,6	9	45	263,4	91,4	35,8	71,6	9	81	227,3	108,2	11,4	23,1	22	45
1035GL	273,6	124,5	24,6	49,3	11	61	314,7	104,1	45,2	90,4	11	102	273,6	124,5	14,0	27,9	33	61
1040GL	320,3	138,7	32,3	64,5	15	79	362,5	119,4	53,3	106,7	15	121	320,3	138,7	16,3	32,5	47	79
1045GL	355,3	154,4	34,8	69,6	16	86	405,6	129,5	59,9	119,9	16	136	355,3	154,4	19,3	38,6	47	86
1050GL	408,2	175,5	41,9	83,8	18	102	459,5	149,9	67,6	135,1	18	153	408,2	175,5	20,6	41,4	61	102
1055GL	470,2	190,8	57,9	115,8	18	134	510,3	167,6	78,0	156,0	18	174	470,2	190,8	21,1	42,2	92	134
1060GL	503,7	211,6	53,1	106,2	21	127	563,1	182,9	82,8	165,6	21	187	503,7	211,6	24,6	49,5	78	127
1070GL	591,8	245,4	62,0	124,0	26	150	664,5	210,8	98,3	196,6	26	223	591,8	245,4	26,9	54,1	96	150

① See page 11 for General Information.

② Gap discs are not required for Sizes 1010 and 1020GL.

③ Peak torque capacity is two times the published rating.

④ Consult Factory for higher speeds. Balancing may allow up to a 50% increase in speeds shown.

⑤ Maximum bores are reduced for hubs furnished with an interference fit and a setscrew over the keyway. Maximum bores may also be reduced when puller bolt holes are required. Refer to Table 13 and Table 14, page 43. Bore capacities can be increased beyond values shown if the coupling torque rating is reduced. Refer to the Factory. Recommended key sizes for the listed maximum bores are shown in Table 35, page 52, and Table 23, page 47.

⑥ Minimum bore is the smallest bore to which a Rough Stock Bore (RSB) hub can be bored. Depending upon coupling size, RSB hubs may have only a blind centering hole or a through hole that will permit remachining of the hubs to the minimum bores specified.

## Type GL52 Standard Flanged Sleeve Slide Single Engagement

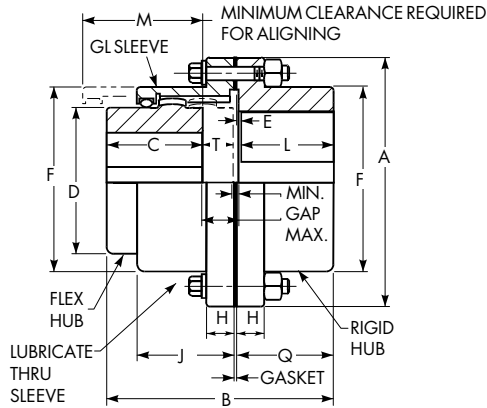

**Type GL52-1 Long Tooth Sleeve  
Reversed Std. Hub**

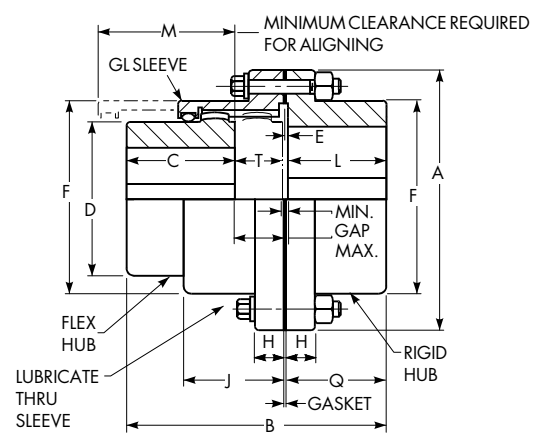

**Type GL52-2 Long Tooth Sleeve  
Cutoff Long Hub**

### Choosing an Assembly

Select the assembly that provides a Total "T" dimension from the table below equal to the application requirements.

- GL52-1 — Moderate slide capacity, moderate price.
- GL52-2 — Greatest slide capacity, highest price.

### Dimensions (mm)

Size ①	Torque Rating (Nm) ②	Allow Speed RPM ③	Max Bore ④		Min Bore ⑤	Cplg Wt with No Bore (kg)	Lube Wt (kg)	A	C	D	E	F	H	J	L	Q
			Flex Hub	Rigid Hub												
1010GL	1 140	5300	50	65	13	4,54	0,0136	115,9	42,9	68,6	2,5	83,8	14,0	38,9	39,6	42,4
1015GL	2 350	4300	65	80	20	9,07	0,0227	152,40	49,3	86,4	2,5	105,2	19,0	47,8	46,2	48,8
1020GL	4 270	3700	78	98	26	15,9	0,0363	177,80	62,0	105,2	2,5	126,5	19,0	59,4	58,4	61,0
1025GL	7 470	3300	98	118	32	29,5	0,0635	212,70	77,0	130,6	2,5	154,9	21,8	71,6	73,7	76,2
1030GL	12 100	2900	111	140	39	43,1	0,1134	239,70	91,2	152,4	2,5	180,3	21,8	83,8	87,9	90,4
1035GL	18 500	2600	134	163	51	68,0	0,1814	279,40	106,4	177,8	2,5	211,3	28,4	97,5	102,1	104,6
1040GL	30 600	2400	160	196	64	99,8	0,2722	317,50	120,6	209,6	4,1	245,4	28,4	111,3	115,3	119,4
1045GL	42 000	2100	183	216	77	136	0,3402	346,10	134,9	235,0	4,1	274,1	28,4	122,9	130,6	134,6
1050GL	56 600	1900	200	235	89	195	0,5443	388,90	153,2	254,0	5,1	305,8	38,1	140,7	147,3	152,4
1055GL	74 000	1800	220	266	102	263	0,7257	425,40	168,1	279,4	5,1	334,3	38,1	158,0	172,7	177,8
1060GL	90 400	1600	244	290	115	324	0,9616	457,20	188,2	304,8	6,6	366,0	25,4	169,2	186,4	193,0
1070GL	135 000	1400	289	340	127	510	1,3608	527,0	220,7	355,6	8,4	424,9	28,4	195,6	220,2	228,6

Size ①	Type GL52-1						Type GL52-2					
	B Max	M	T Max	GAP		B Max	M	T Max	GAP			
				Min	Max				Min	Max		
1010GL	90,2	53,8	3,6	4	8	105,2	58,4	18,5	4	23		
1015GL	112,3	59,7	12,7	4	17	125,0	68,6	25,4	4	30		
1020GL	136,1	77,2	11,7	4	16	153,9	83,8	29,5	4	34		
1025GL	169,7	93,5	14,5	5	19	191,8	101,6	36,3	5	41		
1030GL	204,0	108,2	20,1	5	25	222,0	91,4	38,1	5	43		
1035GL	241,3	124,5	27,2	6	33	261,9	104,1	47,8	6	53		
1040GL	279,4	138,7	36,3	7	43	300,5	119,4	57,4	7	65		
1045GL	314,7	154,4	38,9	8	47	337,8	129,5	64,0	8	72		
1050GL	356,1	175,5	47,0	9	56	381,8	149,9	72,6	9	81		
1055GL	412,5	190,8	63,0	9	72	432,6	167,6	83,1	9	92		
1060GL	444,8	211,6	59,7	10	70	474,5	182,9	89,4	10	100		
1070GL	524,0	245,4	70,4	13	83	560,3	210,8	106,7	13	119		

① See page 11 for General Information.

② Peak torque capacity is two times the published rating.

③ Consult Factory for higher speeds. Balancing may allow up to a 50% increase in speeds shown.

④ Maximum bores are reduced for hubs furnished with an interference fit and a setscrew over the keyway. Maximum bores may also be reduced when puller bolt holes are required. Refer to Table 13 and Table 14, page 43. Bore capacities can be increased beyond values shown if the coupling torque rating is reduced. Refer to the Factory. Recommended key sizes for the listed maximum bores are shown in Table 35, page 52, and Table 23, page 47.

⑤ Minimum bore is the smallest bore to which a Rough Stock Bore (RSB) hub can be bored. Depending upon coupling size, RSB hubs may have only a blind centering hole or a through hole that will permit remachining of the hubs to the minimum bores specified.

# Type G70 Disconnect (Inching Drives)

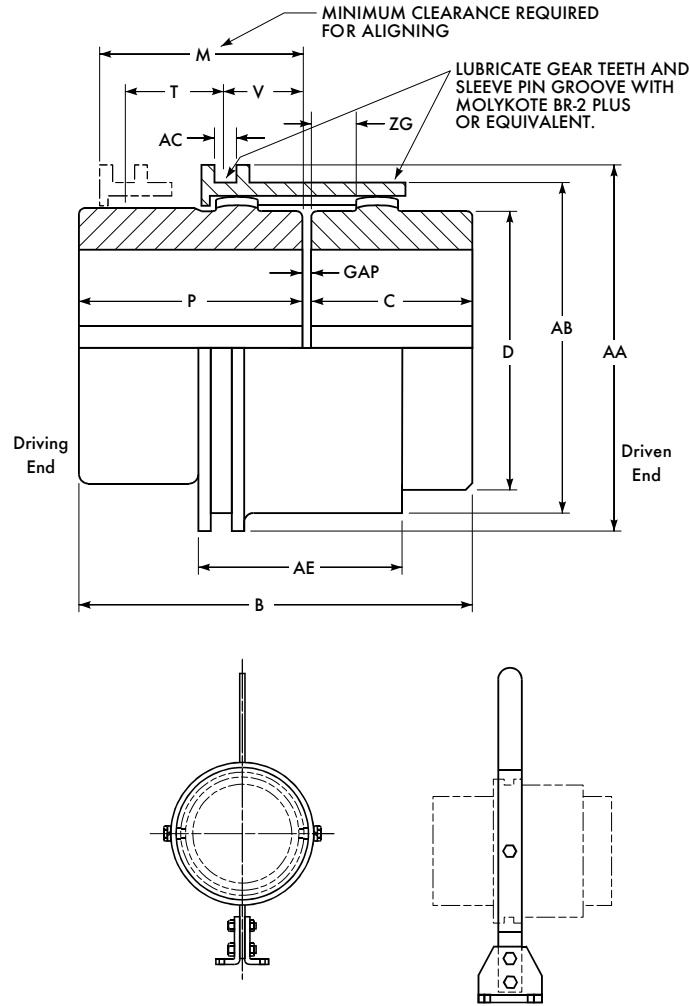

Optional hand-operated shifter mechanism to shift and secure the proper position of the sleeve assembly.

## Dimensions (mm)

Size ①	Torque Rating (Nm) ②	Allow Speed RPM ③	Max Bore ④	Min Bore ⑤	Cplg Wt with No Bore (kg)	B	C	D	M	P	T	V	AA	AB	AC	AE	ZG	GAP
1010G	1 140	630	50	13	4,08	115,8	42,9	68,6	69,6	69,6	30,0	21,8	97,0	83,8	8,1	59,9	14,7	3
1015G	2 350	500	65	20	6,80	120,9	49,3	86,4	68,6	68,6	29,5	21,3	120,9	107,4	8,1	58,9	12,7	3
1020G	4 270	400	78	26	13,6	152,9	62,0	105,2	87,9	87,9	38,1	29,0	145,8	129,5	11,2	78,2	17,8	3
1025G	7 470	330	98	32	24,0	188,5	77,0	130,6	106,7	106,7	48,3	37,6	172,7	156,5	11,2	97,0	21,8	5
1030G	12 100	280	111	39	36,3	215,9	91,2	152,4	119,9	119,9	54,9	42,7	201,2	181,9	14,2	110,2	24,4	5
1035G	18 500	240	134	51	55,8	246,4	106,4	177,8	133,6	133,6	63,0	48,3	231,1	212,1	14,2	124,0	26,9	6
1040G	30 600	200	160	64	83,0	269,7	120,6	209,6	142,7	142,7	67,6	52,8	269,2	250,2	14,2	133,1	27,4	6
1045G	42 000	180	183	77	118,8	305,8	134,9	235,0	163,1	163,1	77,2	59,9	298,2	275,6	17,3	153,4	31,5	8
1050G	56 600	170	200	89	160,1	338,8	153,2	254,0	177,8	177,8	84,3	67,1	331,2	308,9	17,3	167,6	34,8	8
1055G	74 000	150	220	102	199,1	356,6	168,1	279,4	180,3	180,3	85,9	68,1	356,6	334,3	17,3	170,2	32,8	8
1060G	90 400	140	244	115	273,5	406,9	188,2	304,8	210,8	210,8	100,1	81,8	396,7	366,0	19,3	201,2	42,4	8
1070G	135 000	120	289	127	424,1	466,3	220,7	355,6	238,8	236,2	116,8	93,2	455,7	424,9	19,3	229,4	49,8	10

① See page 11 for General Information.

② Peak torque capacity is two times the published rating.

③ Consult Factory for higher speeds. Balancing may allow up to a 50% increase in speeds shown.

④ Maximum bores are reduced for hubs furnished with an interference fit and a setscrew over the keyway. Maximum bores may also be reduced when puller bolt holes are required. Refer to Table 13 and Table 14, page 43. Bore capacities can be increased beyond values shown if the coupling torque rating is reduced. Refer to the Factory. Recommended key sizes for the listed maximum bores are shown in Table 35, page 52, and Table 23, page 47.

⑤ Minimum bore is the smallest bore to which a Rough Stock Bore (RSB) hub can be bored. Depending upon coupling size, RSB hubs may have only a blind centering hole or a through hole that will permit remachining of the hubs to the minimum bores specified.

# Type G72 Disconnect

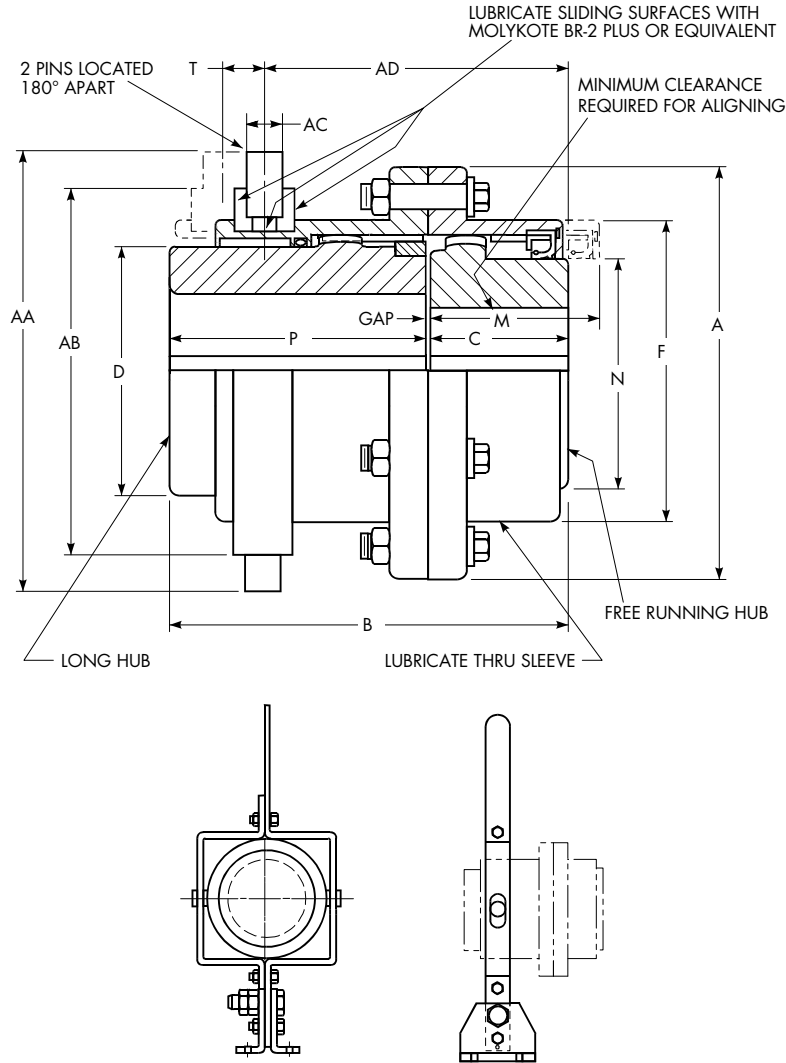

Optional hand-operated shifter mechanism to shift and secure the proper position of the sleeve assembly.

## Dimensions (mm)

Size ①	Torque Rating (Nm) ②	Allow Speed RPM ③	Max Bore ④		Min Bore ⑤	Cplg Wt with No Bore (kg)	Lube Wt (kg)	A	B	C	D	F	M	N	P	T	AA	AB	AC	AD	GAP
			Long Hub	Free Hub																	
1010G	1 140	4200	50	38	13	6,80	0,0318	115,9	128,5	42,7	68,6	83,8	58,4	57,2	82,6	12,7	158,8	127,0	15,7	93,5	3
1015G	2 350	3200	65	52	20	13,2	0,0544	152,4	147,6	52,3	86,4	105,2	76,2	76,2	91,9	14,2	184,2	152,4	15,7	108,2	3
1020G	4 270	2450	78	68	26	22,7	0,0907	177,8	179,3	62,0	105,2	126,5	83,8	98,6	114,3	22,4	196,9	165,1	15,7	136,7	3
1025G	7 470	2000	98	83	32	35,8	0,1724	212,7	214,4	73,2	130,6	154,9	91,4	120,7	136,7	22,4	228,6	190,5	19,1	165,1	5
1030G	12 100	1650	111	102	39	52,2	0,2722	239,7	245,9	98,6	152,4	180,3	106,7	146,1	142,7	25,4	247,7	215,9	22,4	199,6	5
1035G	18 500	1530	134	110	51	81,6	0,4082	279,4	276,4	101,6	177,8	211,3	104,1	158,8	168,1	28,4	301,8	269,7	22,4	219,5	6
1040G	30 600	1200	160	141	64	121	0,6804	317,5	306,1	112,3	209,6	245,4	124,5	203,2	187,5	31,8	352,6	295,1	25,4	245,4	6
1045G	42 000	1060	183	157	77	152	0,7711	346,1	314,5	122,4	235,0	274,1	139,7	225,6	184,2	39,6	393,7	330,2	25,4	251,7	8
1050G	56 600	950	200	187	89	209	1,3608	388,9	360,4	142,7	254,0	305,8	182,9	254,0	209,6	44,5	381,0	323,9	25,4	283,5	8
1055G	74 000	860	220	187	102	278	1,6783	425,4	385,8	168,1	279,4	334,3	184,2	254,0	209,6	53,8	450,9	400,1	28,4	338,1	8
1060G	90 400	830	244	219	115	367	2,3814	457,2	465,1	180,8	304,8	366,0	193,5	292,1	276,4	50,8	463,6	422,1	28,4	369,8	8
1070G	135 000	680	289	276	127	524	3,2659	527,0	479,6	196,9	355,6	424,9	266,7	355,6	273,1	57,2	584,2	508,0	28,4	383,0	10

① See page 11 for General Information.

② Peak torque capacity is two times the published rating.

③ Consult Factory for higher speeds. Balancing may allow up to a 50% increase in speeds shown.

④ Maximum bores are reduced for hubs furnished with an interference fit and a setscrew over the keyway. Maximum bores may also be reduced when puller bolt holes are required. Refer to Table 13 and Table 14, page 43. Bore capacities can be increased beyond values shown if the coupling torque rating is reduced. Refer to the Factory. Recommended key sizes for the listed maximum bores are shown in Table 35, page 52, and Table 23, page 47.

⑤ Minimum bore is the smallest bore to which a Rough Stock Bore (RSB) hub can be bored. Depending upon coupling size, RSB hubs may have only a blind centering hole or a through hole that will permit remachining of the hubs to the minimum bores specified.

# Type GP20/52/82 Standard Flanged Sleeve Insulated

### Type GP20 Double Engagement Coupling

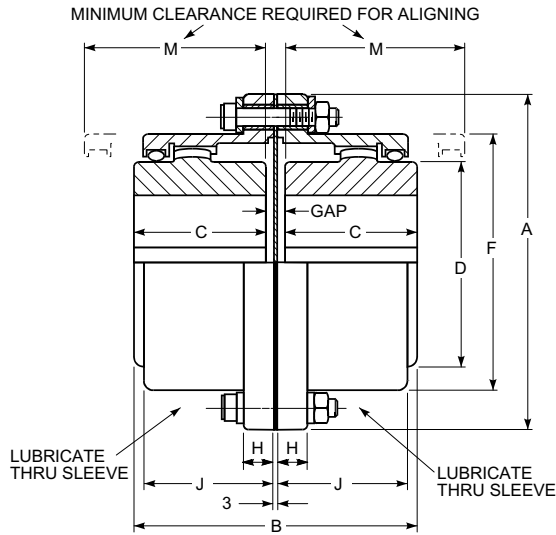

### Type GP52 Single Engagement Coupling

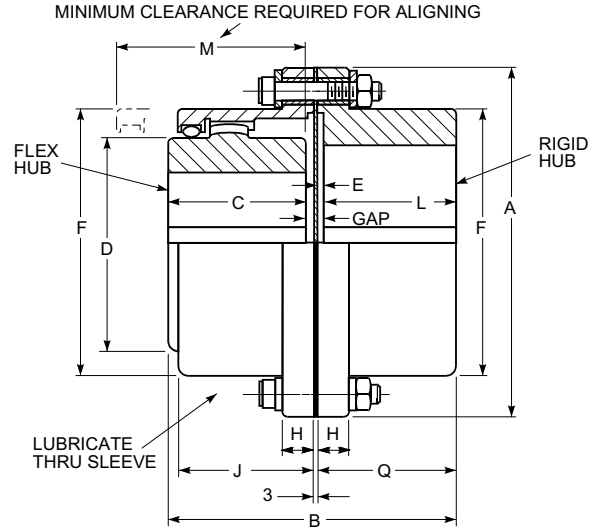

### Type GP82 Rigid Coupling

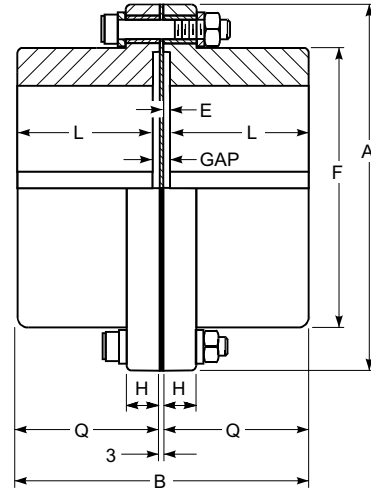

## Dimensions (mm)

Size ①	Torque Rating (Nm) ②	Allow Speed RPM ③	Max Bore ④		Min Bore ⑤	Cplg Wt with No Bore (kg)			Lube Wt (kg)	
			Flex Hub	Rigid Hub		GP20	GP52	GP82	GP20	GP52
1025G	7 470	5000	98	118	32	29,5	27,2	27,2	0,2268	0,1179
1030G	12 100	4400	111	140	39	43,1	43,1	43,1	0,3629	0,1814
1035G	18 500	3900	134	163	51	68,0	68,0	70,3	0,5443	0,2722
1040G	30 600	3600	160	196	64	97,5	99,8	102,1	0,9072	0,4672
1045G	42 000	3200	183	216	77	136,1	136,1	140,6	1,04	0,5670
1050G	56 600	2900	200	235	89	190,5	195,0	204,1	1,77	0,9072
1055G	74 000	2650	220	266	102	249,5	263,1	281,2	2,22	1,13
1060G	90 400	2450	244	290	115	306,2	324,3	335,7	3,18	1,70
1070G	135 000	2150	289	340	127	485,3	508,0	535,2	4,35	2,27

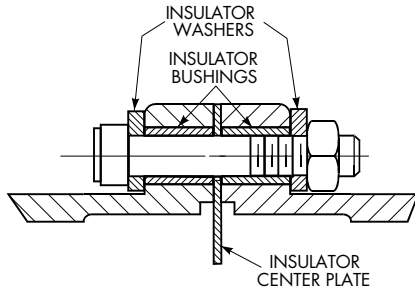

## Dimensions (mm)

Size ①	Flange Bolt		A	B			C	D	E	F	H	J	L	M	Q	GAP		
	Dia & Length	Torque (Nm)		GP20	GP52	GP82										GP20	GP52	GP82
1025GP	0,500-13 x 3,00	47,5	212,70	162,1	158,5	155,4	77,0	130,6	2,5	154,9	21,8	71,6	73,7	92	76,2	8	9	9
1030GP	0,500-13 x 3,00	47,5	239,70	190,2	186,9	183,9	91,2	152,4	2,5	180,3	21,8	83,8	87,9	107	90,4	8	9	9
1035GP	0,625-11 x 4,00	94,9	279,40	222,2	217,2	212,3	106,4	177,8	2,5	211,3	28,4	97,5	102,1	130	104,6	10	9	9
1040GP	0,625-11 x 4,00	94,9	317,50	251,0	245,9	241,8	120,6	209,6	4,1	245,4	28,4	111,3	115,3	145	119,4	10	11	12
1045GP	0,625-11 x 4,00	94,9	346,10	280,9	276,1	272,3	134,9	235,0	4,1	274,1	28,4	122,9	130,6	166	134,6	11	11	12
1050GP	0,750-10 x 5,00	163	388,90	317,2	312,2	307,8	153,2	254,0	5,1	305,8	38,1	140,7	147,3	183	152,4	11	12	14
1055GP	0,750-10 x 5,00	163	425,40	347,5	352,6	358,6	168,1	279,4	5,1	334,3	38,1	158,0	172,7	204	177,8	11	12	14
1060GP	0,750-10 x 4,00	163	457,20	387,1	388,1	389,1	188,2	304,8	6,6	366,0	25,4	169,2	186,4	229	193,0	11	14	17
1070GP	0,875-9 x 4,50	203	527,0	454,4	456,7	460,2	220,7	355,6	8,4	424,9	28,4	195,6	220,2	267	228,6	13	16	20

- ① See page 11 for General Information.
- ② Peak torque capacity is two times the published rating.
- ③ Consult Factory for higher speeds. Balancing may allow up to a 50% increase in speeds shown.
- ④ Maximum bores are reduced for hubs furnished with an interference fit and a setscrew over the keyway. Maximum bores may also be reduced when puller bolt holes are required. Refer to Table 13 and Table 14, page 43. Bore capacities can be increased beyond values shown if the coupling torque rating is reduced. Refer to the Factory. Recommended key sizes for the listed maximum bores are shown in Table 35, page 52, and Table 23, page 47.
- ⑤ Minimum bore is the smallest bore to which a Rough Stock Bore (RSB) hub can be bored. Depending upon coupling size, RSB hubs may have only a blind centering hole or a through hole that will permit remachining of the hubs to the minimum bores specified.

## Type G82 Standard Flanged Sleeve Rigid

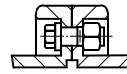
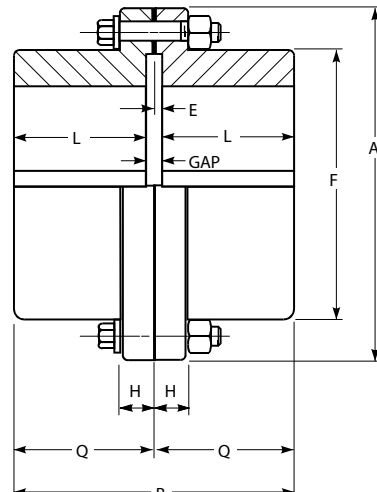

For Sizes 1010G thru 1055G,  
Type G81 Shrouded bolts furnished  
only when specified on the order.

### Dimensions (mm)

Size ①	Torque Rating (Nm) ②	Allow Speed RPM ③	Max Bore ④	Min Bore ⑤	Cplg Wt with No Bore (kg)		A	B	E	F	H	L	Q	GAP
					G81	G82								
1010G	1 140	8000	65	13	4,08	4,54	115,9	84,3	2,5	83,8	14,0	39,6	42,2	5
1015G	2 350	6500	80	20	8,62	9,07	152,40	97,5	2,5	105,2	19,0	46,2	48,8	5
1020G	4 270	5600	98	26	13,6	15,9	177,80	121,9	2,5	126,5	19,0	58,4	61,0	5
1025G	7 470	5000	118	32	24,9	27,2	212,70	152,4	2,5	154,9	21,8	73,7	76,2	5
1030G	12 100	4400	140	39	40,8	43,1	239,70	180,8	2,5	180,3	21,8	87,9	90,4	5
1035G	18 500	3900	163	51	61,2	70,3	279,40	209,3	2,5	211,3	28,4	102,1	104,6	5
1040G	30 600	3600	196	64	95,3	102	317,50	238,8	4,1	245,4	28,4	115,3	119,4	8
1045G	42 000	3200	216	77	132	141	346,10	269,2	4,1	274,1	28,4	130,6	134,6	8
1050G	56 600	2900	235	89	188	204	388,90	304,8	5,1	305,8	38,1	147,3	152,4	10
1055G	74 000	2650	266	102	268	281	425,40	355,6	5,1	334,3	38,1	172,7	177,8	10
1060G	90 400	2450	290	115	—	336	457,20	386,1	6,6	366,0	25,4	186,4	193,0	13
1070G	135 000	2150	340	127	—	535	527,0	457,2	8,4	424,9	28,4	220,2	228,6	17

① See page 11 for General Information.

② Peak torque capacity is two times the published rating.

③ Consult Factory for higher speeds. Balancing may allow up to a 50% increase in speeds shown.

④ Maximum bores are reduced for hubs furnished with an interference fit and a setscrew over the keyway. Maximum bores may also be reduced when puller bolt holes are required. Refer to Table 13 and Table 14, page 43. Bore capacities can be increased beyond values shown if the coupling torque rating is reduced. Refer to the Factory. Recommended key sizes for the listed maximum bores are shown in Table 35, page 52, and Table 23, page 47.

⑤ Minimum bore is the smallest bore to which a Rough Stock Bore (RSB) hub can be bored. Depending upon coupling size, RSB hubs may have only a blind centering hole or a through hole that will permit remachining of the hubs to the minimum bores specified.

## Type GV82 Standard Flanged Sleeve Rigid Thrust

Type GV82 couplings are used as rigid connections for the low-speed shaft of a gear drive and a mixer shaft or suspended load. The coupling carries the torque load, weight of the shaft and impeller, thrust forces and resulting bending moments.

When a rigid coupling is required, the following additional information is necessary.

1. Required thrust capacity and direction of thrust.
2. Radial force at impeller.
3. Distance from the center of coupling fastener flange to the center of the impeller.
4. Weight of shaft and impeller.

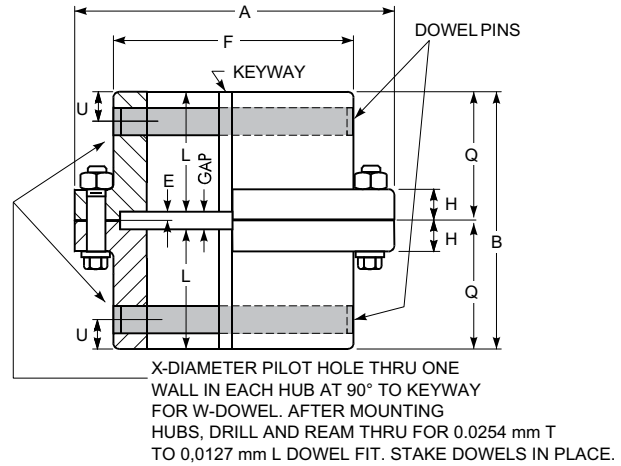
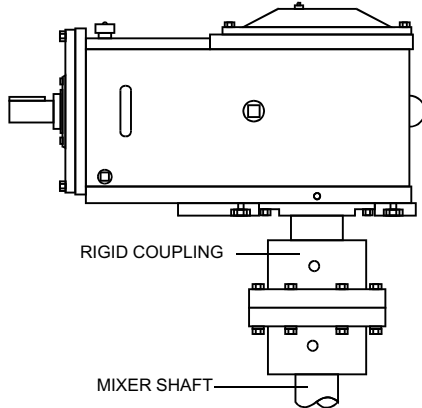

### Dimensions (mm)

Size ①	Torque Rating (Nm) ③	Hub Bore Range ④	Cplg Wt with No Bore (kg)	A	B	E	F	H	L	Q	U	W ②		X	GAP
												Dowel Dia x Length	Dowel Hole-Dia +.0127 -0.0000		
1010GV	1 140	34,9 - 57,2	4,5	115,9	84,3	2,5	83,8	14,0	39,6	42,2	9,7	9,5 x 81,8	9,5	8,7	5
1015GV	2 350	41,3 - 69,8	9,1	152,40	97,5	2,5	105,2	19,0	46,2	48,8	12,7	12,7 x 103,1	12,7	11,9	5
1020GV	4 270	63,5 - 82,6	15,9	177,80	121,3	2,5	126,5	19,0	58,4	61,0	19,1	19,1 x 124,0	19,0	18,3	5
1025GV	7 470	82,6 - 101,6	27,2	212,70	152,4	2,5	154,9	21,8	73,7	76,2	25,4	25,4 x 151,9	25,4	23,8	5
1030GV	12 100	88,9 - 114,3	43,1	239,70	180,8	2,5	180,3	21,8	87,9	90,4	28,4	28,4 x 176,8	28,5	27,0	5
1035GV	18 500	101,6 - 133,4	70,3	279,40	209,3	2,5	211,3	28,4	102,1	104,6	31,8	31,8 x 208,3	31,7	30,2	5
1040GV	30 600	114,3 - 158,8	102	317,50	238,8	4,1	245,4	28,4	115,3	119,4	34,9	34,9 x 241,8	34,9	33,4	8
1045GV	42 000	127,0 - 177,8	141	346,10	261,2	4,1	274,1	28,4	130,6	134,6	38,1	38,1 x 270,3	38,1	36,5	8
1050GV	56 600	146,0 - 196,8	204	388,90	304,8	5,1	305,8	38,1	147,3	152,4	44,5	44,5 x 301,2	44,4	42,9	10
1055GV	74 000	146,0 - 215,9	281	425,40	355,6	5,1	334,3	38,1	172,7	177,8	44,5	44,5 x 330,2	44,4	42,9	10
1060GV	90 400	171,4 - 253,0	336	457,20	386,1	6,6	366,0	25,4	186,4	193,0	50,8	50,8 x 361,2	50,8	49,2	13
1070GV	135 000	171,4 - 273,1	535	527,0	457,2	8,4	424,9	28,4	220,2	228,6	50,8	50,8 x 420,6	50,8	49,2	17

① See page 11 for General Information.

② Dowels: diameters, +0,000 mm, -0,0254 mm material, AISI 4140 hardness, 310-350 HB; furnished by the Factory. Customer is responsible for checking and furnishing driven shaft with satisfactory capacity.

③ Peak torque capacity is two times the published rating.

④ Maximum bores are reduced for hubs furnished with an interference fit and a setscrew over the keyway. Maximum bores may also be reduced when puller bolt holes are required. Refer to Table 13 and Table 14, page 43. Bore capacities can be increased beyond values shown if the coupling torque rating is reduced. Refer to the Factory. Recommended key sizes for the listed maximum bores are shown in Table 35, page 52, and Table 23, page 47.

# Type GR20 Standard Flanged Sleeve Shear Pin/Double Engagement

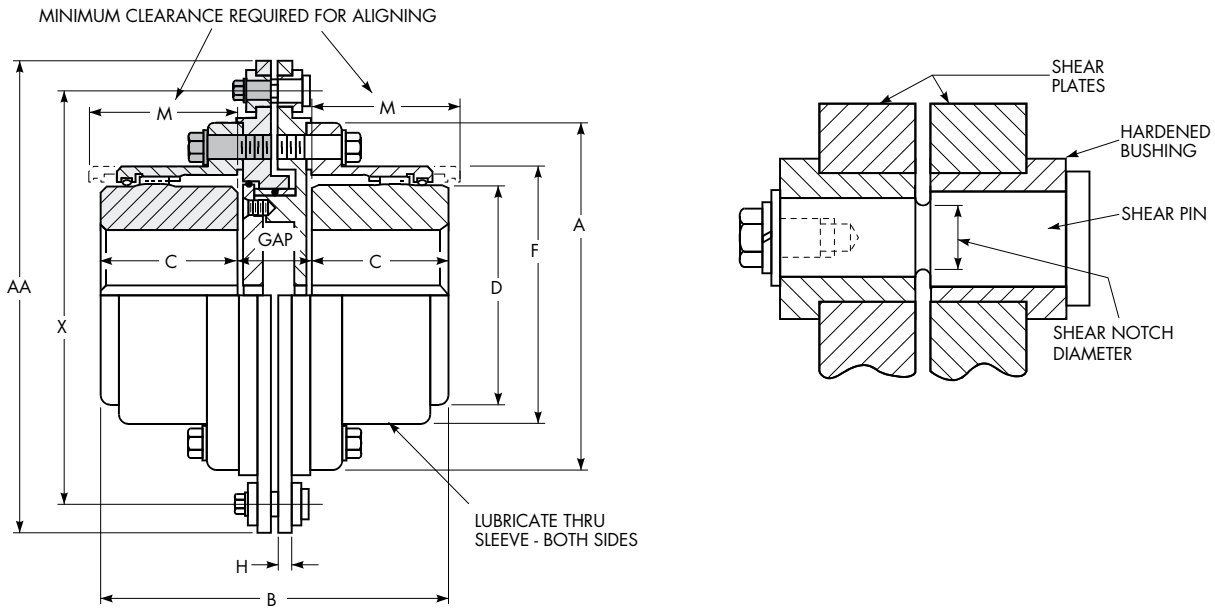

## Dimensions (mm)

Size ①	Torque Rating (Nm) ②	Shear Torque (Nm) ③		Allow Speed RPM ③	Max Bore ④	Min Bore ⑤	Cplg Wt with No Bore (kg)	Lube Wt (kg)	A	B	C	D	F	H	M	X	AA	GAP
		Min	Max															
1010GR	1 140	124	1 073	5,000	50	13	8,62	0,0408	115,9	121,7	42,9	68,6	83,8	9,1	50,8	147,6	173,0	36
1015GR	2 350	282	2 407	4,000	65	20	15,0	0,0726	152,4	138,2	49,3	86,4	105,2	9,1	61,0	184,2	209,6	40
1020GR	4 270	599	4 452	3,600	78	26	28,1	0,113	177,8	170,2	62,0	105,2	126,5	12,2	76,2	209,6	235,0	46
1025GR	7 470	1 062	8 011	2,700	98	32	49,0	0,2127	212,7	201,7	77,0	130,6	154,9	12,2	91,4	266,7	317,5	48
1030GR	12 100	1 774	13 344	2,400	111	39	66,2	0,363	239,7	234,2	91,2	152,4	180,3	12,2	106,7	293,7	338,1	52
1035GR	18 500	2 542	20 462	2,100	134	51	102	0,544	279,4	273,3	106,4	177,8	211,3	12,2	129,5	333,4	377,8	60
1040GR	30 600	3 141	31 139	1,900	160	64	138	0,907	317,5	301,8	120,6	209,6	245,4	12,2	144,8	371,5	415,9	60
1045GR	42 000	5 435	42 708	1,800	183	77	185	1,04	346,1	330,2	134,9	235,0	274,1	12,2	165,1	400,1	450,9	60
1050GR	56 600	6 982	57 837	1,750	200	89	279	1,77	388,9	394,5	153,2	254,0	305,8	24,9	182,9	438,2	482,6	88
1055GR	74 000	8 926	75 632	1,500	220	102	362	2,22	425,4	424,4	168,1	279,4	334,3	24,9	203,2	482,6	533,4	88
1060GR	90 400	12 575	100 139	1,400	244	115	441	3,18	457,2	464,6	188,2	304,8	366,0	24,9	228,6	520,7	590,8	88
1070GR	135 000	18 044	142 429	1,250	289	127	670	4,35	527,0	529,6	220,7	355,6	424,9	24,9	266,7	590,6	660,4	88

- ① See page 11 for General Information. Minimum and maximum bores are the same as those for Type G20, page 15.
- ② Peak torque capacity is two times the published rating.
- ③ Consult Factory for higher speeds. Balancing may allow up to a 50% increase in speeds shown.
- ④ Maximum bores are reduced for hubs furnished with an interference fit and a setscrew over the keyway. Maximum bores may also be reduced when puller bolt holes are required. Refer to Table 13 and Table 14, page 43. Bore capacities can be increased beyond values shown if the coupling torque rating is reduced. Refer to the Factory. Recommended key sizes for the listed maximum bores are shown in Table 35, page 52, and Table 23, page 47.
- ⑤ Minimum bore is the smallest bore to which a Rough Stock Bore (RSB) hub can be bored. Depending upon coupling size, RSB hubs may have only a blind centering hole or a through hole that will permit remachining of the hubs to the minimum bores specified.

Table 8 — Shear Pin Design Criteria

Size	Shear Torque (Nm)			
	2-Pin Design		4-Pin Design	
	Minimum	Maximum	Minimum	Maximum
1010GR	124	427	428	1 073
1015GR	282	960	962	2 407
1020GR	599	1 780	1 781	4 452
1025GR	1 062	3 203	3 204	8 011
1030GR	1 774	5 339	5 340	13 344
1035GR	2 542	8 186	8 187	20 462
1040GR	3 141	12 457	12 458	31 139
1045GR	5 435	17 083	17 084	42 708
1050GR	6 982	23 134	23 135	57 837
1055GR	8 926	30 257	30 258	75 632
1060GR	12 575	40 053	40 054	100 139
1070GR	18 044	56 944	56 945	142 429

# Type G Standard Flanged Sleeve Mill Motor & Taper Bores

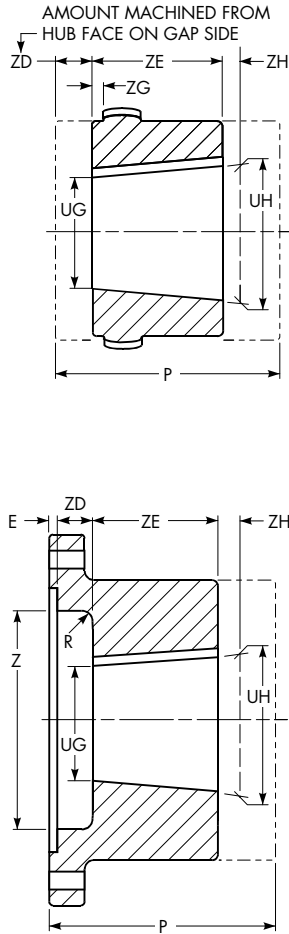

**Table 9 — Standard AISE AC & DC Mill Motor Coupling Selections – Dimension (mm)**

Motor Frame Size			Coupling Size ①	E	R	UG	UH	Keyway	Z	ZD	ZE	ZG	ZH + .000 - .000
2 602	802 A, B & C	AC 1, 2 & 4	1015G	2,5								1,5	
			1020G	2,5	7,9	36,5	44,4	12,7 x .6,4	82,6	23,9	76,2	5,6	0,6
			1025G	2,5									12,4
603 604	803 804	—	1015G	2,5								0,0	
			1020G	2,5	9,7	41,5	50,8	12,7 x 6,4	85,7	25,4	88,9	4,1	0,7
			1025G	2,5									10,9
606	806	AC 8 & 12	1030G	2,5								19,1	
			1035G	2,5	9,7	52,9	63,5	12,7 x 6,4	101,6	28,4	101,6	7,6	0,7
			1040G	2,5									15,7
608	808	—	1045G	2,5								25,4	
			1050G	2,5	12,7	64,3	76,2	19,0 x 6,4	133,4	31,8	114,3	4,6	0,7
			1055G	2,5									12,7
610	810	AC18	1060G	2,5								32,0	
			1065G	2,5	12,7	70,6	82,6	19,0 x 6,4	142,9	35,1	114,3	4,6	0,9
			1070G	2,5									19,3
612	812	AC 25 & 30	1075G	2,5								29,0	
			1080G	2,5	12,7	78,8	92,1	19,0 x 6,4	158,8	38,1	127,0	6,4	0,9
			1085G	2,5									16,0
614	814	AC 40 & 50	1090G	2,5								32,3	
			1095G	2,5	12,7	94,7	108,0	25,4 x 9,5	174,6	41,1	127,0	12,7	0,9
			1100G	2,5									22,6
616	816	—	1105G	2,5								40,6	
			1110G	2,5	15,7	102,9	115,8 ③	31,8 x 9,5	195,3 ③	44,4	123,7 ③	0,38	0,9
			1115G	2,5									0,76
618	818	—	1120G	2,5								1,02	
			1125G	2,5	15,7	111,1	127,0	31,8 x 12,7	212,7	33,5	152,4	1,46	1,0
			1130G	2,5									37,3
620	820	—	1135G	2,5								48,5	
			1140G	2,5	19,0	131,4	149,2	38,1 x 19,0	247,6	44,4	171,4	25,9	1,0
			1145G	2,5									37,3
622	822	—	1150G	2,5								51,3	
			1155G	2,5	19,0	139,6	158,8	38,1 x 19,0	247,6	60,2	184,2	10,2	1,0
			1160G	2,5									21,6
624	824	—	1165G	2,5								41,7	
			1170G	2,5	19,0	153,3	177,8	38,1 x 19,0	247,6	60,2	235,0	21,3	1,0
			1175G	2,5									35,3
			1180G	2,5							41,7		
			1185G	2,5							59,7		

① See page 11 for General Information. Minimum coupling selections are based on coupling bore capacity. Check coupling rating for all selections. Refer to pages 15 and 17 for coupling dimensions.

② Spanner wrench required for Size 1025G.

③ For rigid hub only.

**Table 10 — Taper and Counter Bore Limitations ④ – Dimension (mm)**

Size ①	Flex Hub					Rigid Hub				
	P Max ⑤	UG Min	UH Max ⑥	ZD Max	ZE Min	P Max ⑤	UG Min	UH Max ⑥	ZD Max	ZE Min
1010G	101,6	12,7	50	18,5	42,9	104,1	12,7	65	76,2	39,6
1015G	114,3	19,0	65	25,4	49,3	116,8	19,0	80	85,9	46,2
1020G	130,0	25,4	78	29,5	62,0	132,6	25,4	98	101,6	58,4
1025G	149,4	31,8	98	36,3	77,0	151,9	31,8	118	142,7	73,7
1030G	165,1	38,1	111	44,4	91,2	167,6	38,1	140	158,8	87,9
1035G	184,2	50,8	134	54,1	106,4	170,7	50,8	163	174,8	102,1
1040G	203,2	63,5	160	63,8	120,6	191,0	63,5	196	212,9	114,3
1045G	244,3	76,2	183	70,4	134,9	249,4	76,2	216	247,6	129,5
1050G	295,1	88,9	200	81,8	153,2	300,2	88,9	235	273,0	147,3
1055G	298,4	101,6	220	95,8	168,1	303,3	101,6	266	298,5	172,7
1060G	304,8	114,3	244	102,1	188,2	311,2	114,3	290	330,2	186,4
1070G	309,9	127,0	289	120,1	220,7	312,9	127,0	340	381,0	220,2

④ This table specifies the taper limitations for the usual requirements. For hubs longer than those listed, refer to the Factory.

⑤ Standard Long Hub length; consult the Factory for longer lengths.

⑥ Keyway for keys shown in Table 13, page 43.

# Type G20 Large Flanged Sleeve Double Engagement

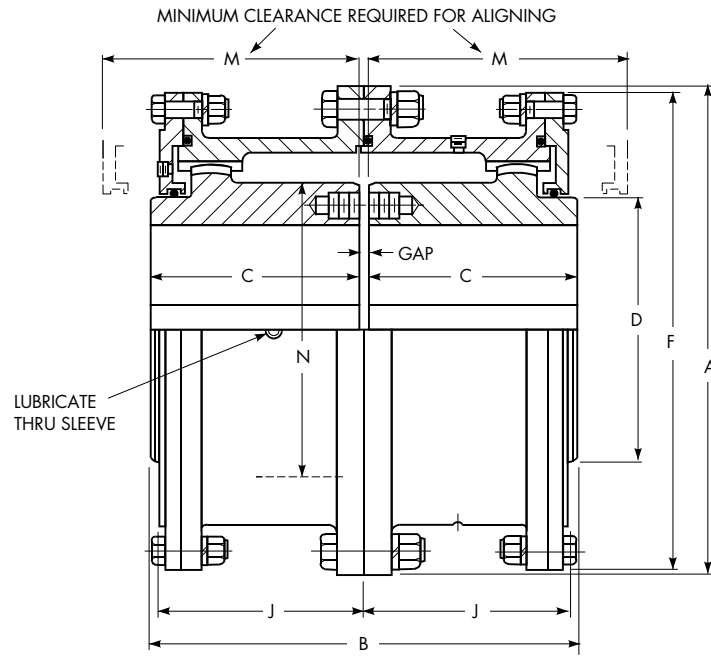

## Dimensions (mm)

Size ①	Torque Rating (Nm – millions) ③		Allow Speed RPM ④	Max Bore One Rect Key ⑤	Min Bore ⑥	Cplg Wt with No Bore (kg)	Lube Wt (kg)	A	B	C	D	F	J	M	N	GAP
	1000 Series	2000 Series														
1080/2080G	0,170	0,234	1750	266	101,60	703	9,5	590,6	508,5	249,2	355,6	571,5	242,8	300,0	368,3	10
1090/2090G	0,226	0,315	1550	290	114,30	984	12,2	660,4	565,4	276,4	393,7	641,4	265,2	327,2	419,1	13
1100/2100G	0,310	0,443	1450	320	127,00	1 302	15,0	711,2	622,3	304,8	444,5	698,5	293,6	355,6	469,9	13
1110/2110G	0,413	0,609	1330	373	139,70	1 678	17,7	774,7	679,2	333,2	495,3	749,3	322,3	384,0	520,7	13
1120/2120G	0,555	0,777	1200	400	152,40	2 114	20,9	838,2	717,8	352,6	546,1	825,5	341,4	403,4	571,5	13
1130/2130G	0,719	0,925	1075	440	165,10	2 595	32,7	911,4	761,7	371,3	584,2	886,0	362,0	434,8	609,6	19
1140/2140G	0,911	1,140	920	460	177,80	3 107	33,1	965,2	806,4	393,2	635,0	939,8	378,0	457,2	660,4	19
1150/2150G	1,100	1,350	770	490	190,50	3 765	40,8	1 028,7	857,2	419,1	685,8	1 003,3	407,9	482,6	711,2	19
1160/2160G	1,310	1,640	650	525 ②	254,00	4 708	43,1	1 111,2	908,0	441,3	736,6	1 085,9	419,1	501,6	762,0 ②	25
1180/2180G	1,660	2,140	480	600 ②	285,75	6 260	49,9	1 219,2	939,8	457,2	838,2	1 193,8	434,8	520,7	863,6 ②	25
1200/2200G	2,140	2,850	370	660 ②	317,50	8 582	68,0	1 358,9	1 098,6	536,6	927,1	1 308,1	514,4	635,0	965,2 ②	25
1220/2220G	2,720	3,560	290	725 ②	349,25	11 685	107	1 511,3	1 193,8	584,2	1 016,0	1 473,2	565,2	685,8	1 066,8 ②	25
1240/2240G	3,470	4,480	270	810 ②	381,00	14 606	109	1 632,0	1 282,7	628,6	1 130,3	1 581,2	606,6	723,9	1 168,4 ②	25
1260/2260G	4,490	5,480	250	880 ②	412,75	17 799	122	1 746,2	1 371,6	673,1	1 231,9	1 695,4	647,7	774,7	1 270,0 ②	25
1280/2280G	5,840	6,760	230	950 ②	444,50	21 192	136	1 866,9	1 409,7	692,9	1 333,5	1 803,4	666,8	793,8	1 371,6 ②	25
1300/2300G	6,760	8,190	220	1 025 ②	476,25	24 807	150	1 974,8	1 447,8	711,2	1 435,1	1 911,4	685,8	800,1	1 473,2 ②	25

- ① See page 11 for General Information.
- ② Reduced shank diameter hubs are available where required bore permits. See Table 32, page 50 for selection.
- ③ Peak torque capacity is two times the published rating.
- ④ Consult Factory for higher speeds. Balancing may allow up to a 50% increase in speeds shown.
- ⑤ Maximum bores are reduced for hubs furnished with an interference fit and a setscrew over the keyway. Refer to Table 13 and Table 14, page 43. Bore capacities can be increased beyond values shown if the coupling torque rating is reduced. Refer to the Factory. Recommended key sizes for the listed maximum bores are shown in Table 35, page 52, and Table 23, page 47.
- ⑥ Minimum bore is the smallest bore to which a Rough Stock Bore (RSB) hub can be bored. Depending upon coupling size, RSB hubs may have only a blind centering hole or a through hole that will permit remachining of the hubs to the minimum bores specified.

Table 11 — Limited End Float & Standard Gap Disc Dimensions (mm)

Size	B	End Float ⑦	Gap Disc ⑧		GAP
			Thickness	Dia	
1080/2080G	517,1	4,78	16	416	18
1090/2090G	577,3	4,78	22	470	25
1100/2100G	634,2	4,78	22	521	25
1110/2110G	691,1	4,78	22	568	25
1120/2120G	729,7	4,78	22	622	25
1130/2130G	778,5	4,78	33	676	36
1140/2140G	822,2	4,78	33	727	36
1150/2150G	874,0	4,78	33	778	36

- ⑦ If this value exceeds one-half rotor end float or equivalent manufacturer's specifications, refer to the Factory.
- ⑧ Gap disc material: Neoprene, 70 durometer.

# Type G52 Large Flanged Sleeve Single Engagement

**IMPORTANT:** When couplings are mounted on a floating shaft, do not exceed allowable shaft speed for the assembly. Use a gap disc in each coupling.

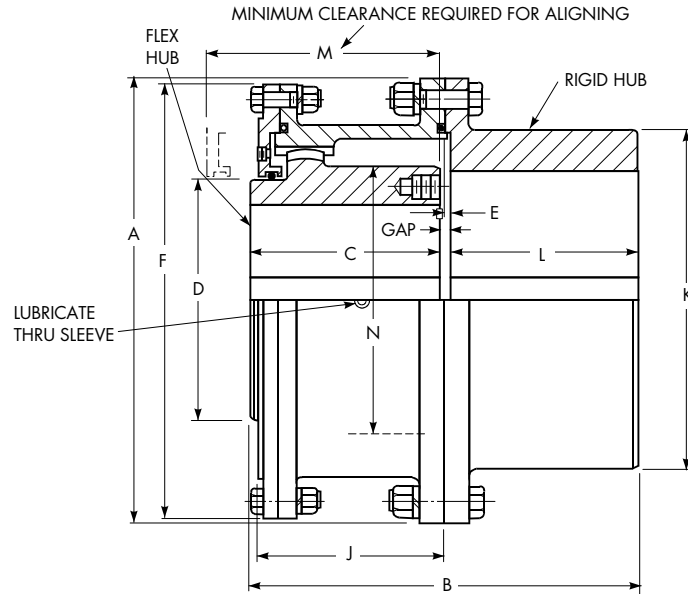

## Dimensions (mm)

Size ①	Torque Rating (Nm – millions) ④		Allow Speed RPM ⑤	Max Bore One Rect Key ⑥		Min Bore ⑦	Cplg Wt with No Bore(kg)	Lube Wt (kg)	A	B	C	D	E	F	J	K ③	L	M	N	GAP
	1000 Series	2000 Series		Flex Hub	Rigid Hub															
1080/2080G	0,170	0,234	1750	266	340	101,60	699	5	590,6	511,0	249,4	355,6	8,1	571,5	242,8	450,8	248,9	300,0	368,3	13
1090/2090G	0,226	0,315	1550	290	380	114,30	984	6	660,4	566,4	276,4	393,7	8,1	641,4	265,2	508,0	275,8	327,2	419,1	14
1100/2100G	0,310	0,443	1450	320	400	127,00	1 252	8	711,2	625,3	304,8	444,5	9,7	698,5	293,6	530,4	304,8	355,6	469,9	16
1110/2110G	0,413	0,609	1330	373	440	139,70	1 637	9	774,7	682,2	333,2	495,3	9,7	749,3	322,3	584,2	333,2	384,0	520,7	16
1120/2120G	0,555	0,777	1200	400	483	152,40	2 077	11	838,2	720,6	352,6	546,1	9,7	825,5	341,4	647,7	352,3	403,4	571,5	16
1130/2130G	0,719	0,925	1075	440	500	165,10	2 572	17	911,4	761,7	371,3	584,2	9,7	886,0	362,0	708,2	371,3	434,8	609,6	19
1140/2140G	0,911	1,140	920	460	535	177,80	3 062	17	965,2	805,9	393,2	635,0	9,7	939,8	378,0	749,3	393,7	457,2	660,4	19
1150/2150G	1,100	1,350	770	490	580	190,50	3 751	21	1 028,7	857,2	419,1	685,8	9,7	1 003,3	407,9	812,8	419,1	482,6	711,2	19
1160/2160G	1,310	1,640	650	525 ②	630 ②	254,00	4 631	22	1 111,2	908,3	441,3	736,6	12,7	1 085,8	419,1	886,0 ②	441,5	501,6	762,0 ②	25
1180/2180G	1,660	2,140	480	600 ②	710 ②	285,75	6 069	25	1 219,2	939,8	457,2	838,2	12,7	1 193,8	434,8	993,6 ②	457,2	520,7	863,6 ②	25
1200/2200G	2,140	2,850	370	660 ②	780 ②	317,50	8 482	34	1 358,9	1 098,6	536,6	927,1	12,7	1 308,1	514,4	1 095,2 ②	536,4	635,0	965,2 ②	25
1220/2220G	2,720	3,560	290	725 ②	890 ②	349,25	11 680	54	1 511,3	1 196,8	584,2	1 016,0	15,7	1 473,2	565,2	1 244,6 ②	584,2	685,8	1 066,8 ②	28
1240/2240G	3,470	4,480	270	810 ②	940 ②	381,00	14 388	57	1 632,0	1 285,7	628,6	1 130,3	15,7	1 581,2	606,6	1 314,7 ②	628,6	723,9	1 168,4 ②	28
1260/2260G	4,490	5,480	250	880 ②	1 015 ②	412,75	17 722	61	1 746,2	1 374,6	673,1	1 231,9	15,7	1 695,5	647,7	1 422,4 ②	673,1	774,7	1 270,0 ②	28
1280/2280G	5,840	6,760	230	950 ②	1 090 ②	444,50	21 110	70	1 866,9	1 412,2	691,9	1 333,5	15,7	1 803,4	666,8	1 530,6 ②	691,9	793,8	1 371,6 ②	28
1300/2300G	6,760	8,190	220	1 025 ②	1 170 ②	476,25	24 712	77	1 974,8	1 450,8	711,2	1 435,1	15,7	1 911,4	685,8	1 638,3 ②	711,2	800,1	1 473,2 ②	28

- ① See page 11 for General Information.
- ② Reduced shank diameter hubs are available where required bore permits. See Table 32, page 50 for selection.
- ③ Dimension K may be an “as-cast” surface, depending upon coupling size and bore.
- ④ Peak torque capacity is two times the published rating.
- ⑤ Consult Factory for higher speeds. Balancing may allow up to a 50% increase in speeds shown.
- ⑥ Maximum bores are reduced for hubs furnished with an interference fit and a setscrew over the keyway. Refer to Table 13 and Table 14, page 43. Bore capacities can be increased beyond values shown if the coupling torque rating is reduced. Refer to the Factory. Recommended key sizes for the listed maximum bores are shown in Table 35, page 52, and Table 23, page 47.
- ⑦ Minimum bore is the smallest bore to which a Rough Stock Bore (RSB) hub can be bored. Depending upon coupling size, RSB hubs may have only a blind centering hole or a through hole that will permit remachining of the hubs to the minimum bores specified.

# Type G52 Large Flanged Sleeve Single Engagement

## Floating Shaft

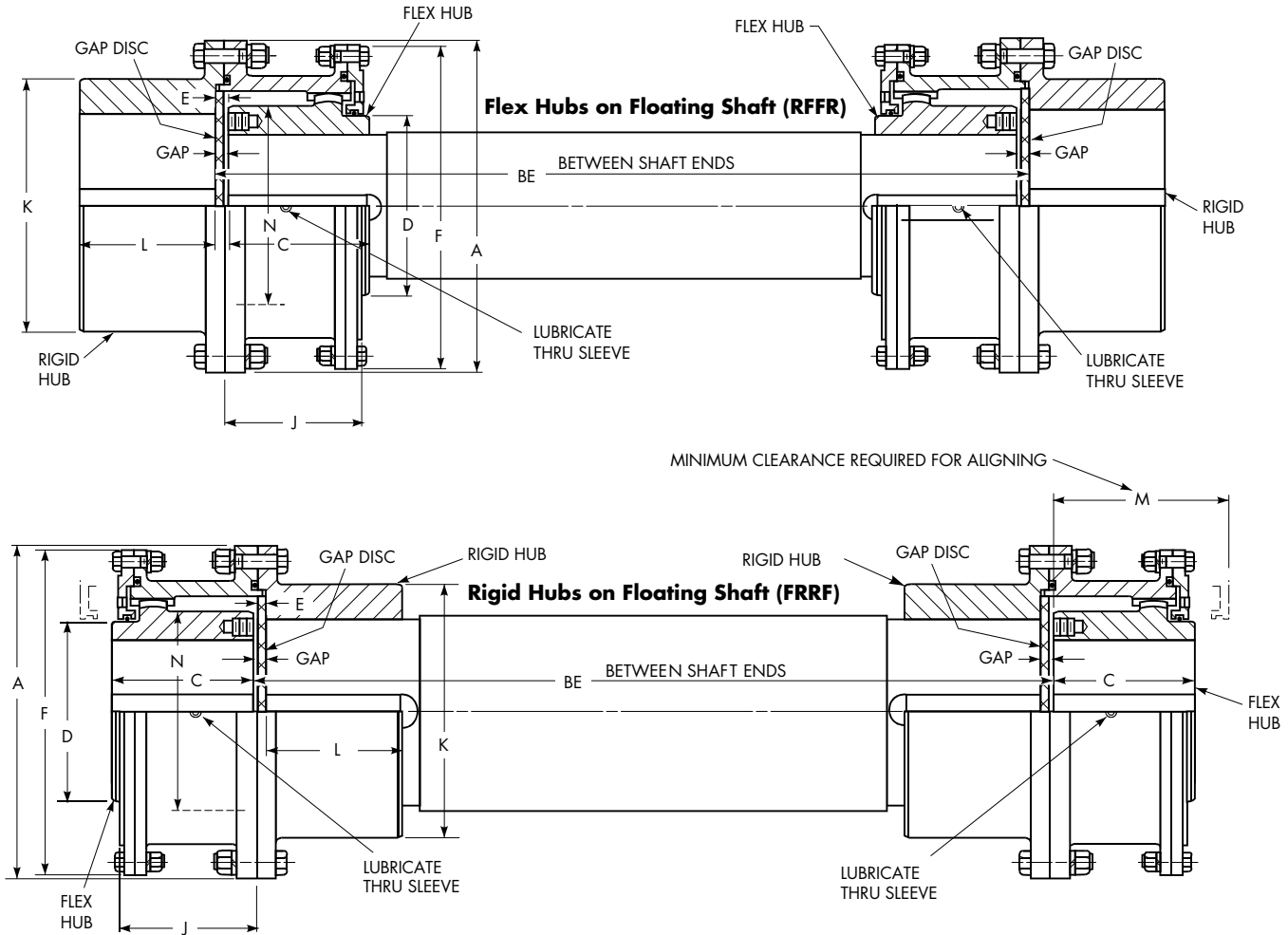

## Dimensions (mm)

Size ①	Torque Rating (Nm – millions) ⑤		Allow Speed RPM ③	Max Bore One Rect Key ⑥		Cplg Wt with No Bore (kg)	Lube Wt (kg)	A	BE Min		C	D	E	F	J	K ④	L	M	N	GAP
	1000 Series	2000 Series		Flex Hub	Rigid Hub				RFRF	FRRF										
	1080/2080G	0,170		0,234	1300				266	340										
1090/2090G	0,226	0,315	1160	290	380	984	6	660,4	825,5	606,6	276,4	393,7	8,1	641,4	265,2	508,0	275,8	327,2	419,1	14
1100/2100G	0,310	0,443	1090	320	400	1 252	8	711,2	927,1	666,8	304,8	444,5	9,7	698,5	293,6	530,4	304,8	355,6	469,9	16
1110/2110G	0,413	0,609	1000	373	440	1 637	9	774,7	1 028,7	723,9	333,2	495,3	9,7	749,3	322,3	584,2	333,2	384,0	520,7	16
1120/2120G	0,555	0,777	900	400	483	2 077	11	838,2	1 104,9	762,0	352,6	546,1	9,7	825,5	341,4	647,7	352,3	403,4	571,5	16
1130/2130G	0,719	0,925	800	440	500	2 572	17	911,4	1 130,3	806,4	371,3	584,2	9,7	886,0	362,0	708,2	371,3	434,8	609,6	19
1140/2140G	0,911	1,140	700	460	535	3 062	17	965,2	1 181,1	850,9	393,2	635,0	9,7	939,8	378,0	749,3	393,7	457,2	660,4	19
1150/2150G	1,100	1,350	580	490	580	3 751	21	1 028,7	1 295,4	901,7	419,1	685,8	9,7	1 003,3	407,9	812,8	419,1	482,6	711,2	19
1160/2160G	1,310	1,640	490	525 ⌀	630 ⌀	4 631	22	1 111,2	1 320,8	958,8	441,3	736,6	12,7	1 085,7	419,1	886,0 ⌀	441,5	501,7	762,0 ⌀	25
1180/2180G	1,660	2,140	360	600 ⌀	710 ⌀	6 069	25	1 219,2	1 358,9	990,6	457,2	838,2	12,7	1 193,8	434,8	993,6 ⌀	457,2	520,7	863,6 ⌀	25
1200/2200G	2,140	2,850	280	660 ⌀	780 ⌀	8 482	34	1 358,9	1 651,0	1 149,4	536,6	927,1	12,7	1 308,1	514,4	1 095,2 ⌀	536,4	635,0	965,2 ⌀	25
1220/2220G	2,720	3,560	220	725 ⌀	890 ⌀	11 680	54	1 511,3	1 828,8	1 251,0	584,2	1 016,0	15,7	1 473,2	565,2	1 244,6 ⌀	584,2	685,8	1 066,8 ⌀	28
1240/2240G	3,470	4,480	200	810 ⌀	940 ⌀	14 388	57	1 632,0	1 993,9	1 339,8	628,6	1 130,3	15,7	1 581,2	606,6	1 314,7 ⌀	628,6	723,9	1 168,4 ⌀	28
1260/2260G	4,490	5,480	190	880 ⌀	1 015 ⌀	17 722	61	1 746,2	2 159,0	1 428,8	673,1	1 231,9	15,7	1 695,4	647,7	1 422,4 ⌀	673,1	774,7	1 270,0 ⌀	28
1280/2280G	5,840	6,760	175	950 ⌀	1 090 ⌀	21 110	70	1 866,9	2 222,5	1 454,2	691,9	1 333,5	15,7	1 803,4	666,8	1 530,6 ⌀	691,9	793,8	1 371,6 ⌀	28
1300/2300G	6,760	8,190	165	1 025 ⌀	1 170 ⌀	24 712	77	1 974,8	2 286,0	1 505,0	711,2	1 435,1	15,7	1 911,4	685,8	1 638,3 ⌀	711,2	800,1	1 473,2 ⌀	28

- ① See page 11 for General Information.
- ② Reduced shank diameter hubs are available where required bore permits. See Table 32, page 50 for selection.
- ③ Dimension K may be an “as-cast” surface, depending upon coupling size and bore.
- ④ The allowable speed for floating shaft assemblies is the smaller value of either the critical speed of the selected shaft or the cataloged speed of the selected size coupling. The allowable operating speed should be based on torque, misalignment, balance and other operating requirements for the specific application. If higher speeds are required or special application requirements must be met, consult the Factory for assistance.
- ⑤ Peak torque capacity is two times the published rating.
- ⑥ Maximum bores are reduced for hubs furnished with an interference fit and a setscrew over the keyway. Refer to Table 13 and Table 14, page 43. Bore capacities can be increased beyond values shown if the coupling torque rating is reduced. Refer to the Factory. Recommended key sizes for the listed maximum bores are shown in Table 35, page 52, and Table 23, page 47.

NOTE: Dimensions subject to change. Certified dimensions of ordered material furnished on request.

## Type GV20 Large Flanged Sleeve Vertical Double Engagement

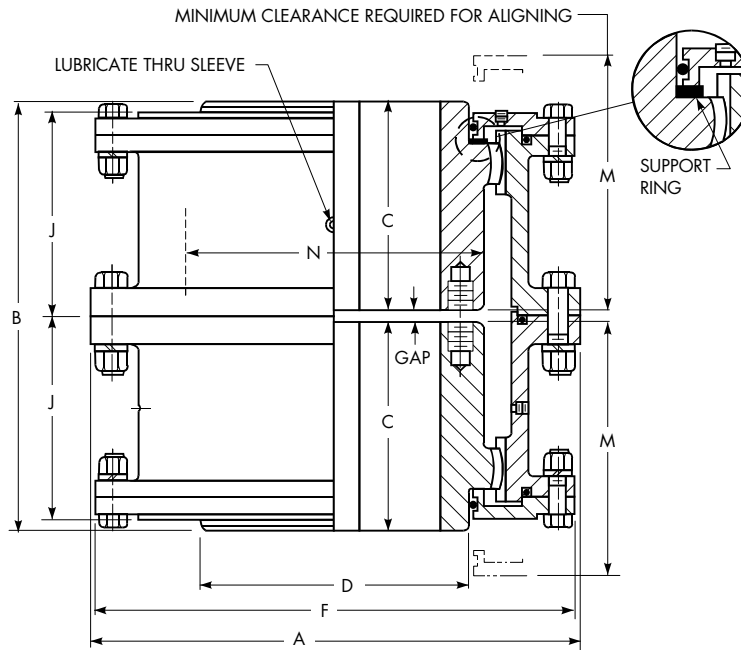

### Dimensions (mm)

Size ①	Torque Rating (Nm – millions) ③		Allow Speed RPM ④	Max Bore One Rect Key ⑤	Min Bore ⑥	Cplg Wt with No Bore (kg)	Lube Wt (kg)	A	B	C	D	F	J	M	N	GAP
	1000 Series	2000 Series														
1080/2080GV	0,170	0,234	1,750	266	102	703	9,5	590,6	508,5	249,4	355,6	571,5	242,8	300,0	368,3	10
1090/2090GV	0,226	0,315	1,550	290	114	984	12,2	660,4	565,4	276,4	393,7	641,4	265,2	327,2	419,1	13
1100/2100GV	0,310	0,443	1,450	320	127	1302	15,0	711,2	622,3	304,8	444,5	698,5	293,6	355,6	469,9	13
1110/2110GV	0,413	0,609	1,330	373	140	1678	17,7	774,7	679,2	333,2	495,3	749,3	322,3	384,0	520,7	13
1120/2120GV	0,555	0,777	1,200	400	152	2114	20,9	838,2	717,8	352,6	546,1	825,5	341,4	403,4	571,5	13
1130/2130GV	0,719	0,925	1,075	440	165	2595	32,7	911,4	761,7	371,3	584,2	886,0	362,0	434,8	609,6	19
1140/2140GV	0,911	1,140	920	460	178	3107	33,1	965,2	805,4	393,2	635,0	939,8	378,0	457,2	660,4	19
1150/2150GV	1,100	1,350	770	490	190	3765	40,8	1028,7	857,3	419,1	685,8	1003,3	407,9	482,6	711,2	19
1160/2160GV	1,310	1,640	650	525 Ⓣ	254	4708	43,1	1111,3	908,1	441,3	736,6	1085,9	419,1	501,7	762,0 Ⓣ	25
1180/2180GV	1,660	2,140	480	600 Ⓣ	286	6260	49,9	1219,2	939,8	457,2	838,2	1193,8	434,8	520,7	863,6 Ⓣ	25
1200/2200GV	2,140	2,850	370	660 Ⓣ	317	8582	68,0	1358,9	1098,6	536,6	927,1	1308,1	514,4	635,0	965,2 Ⓣ	25
1220/2220GV	2,720	3,560	290	725 Ⓣ	349	11685	107	1511,3	1193,8	584,2	1016,0	1473,2	565,2	685,8	1066,8 Ⓣ	25
1240/2240GV	3,470	4,480	270	810 Ⓣ	381	14606	109	1632,0	1282,7	628,7	1130,3	1581,2	606,6	723,9	1168,4 Ⓣ	25
1260/2260GV	4,490	5,480	250	880 Ⓣ	413	17799	122	1746,3	1371,6	673,1	1231,9	1695,5	647,7	774,7	1270,0 Ⓣ	25
1280/2280GV	5,840	6,760	230	950 Ⓣ	445	21192	136	1866,9	1409,2	691,9	1333,5	1803,4	666,8	793,8	1371,6 Ⓣ	25
1300/2300GV	6,760	8,190	220	1025 Ⓣ	476	24807	150	1974,9	1447,8	711,2	1435,1	1911,4	685,8	800,1	1473,2 Ⓣ	25

① See page 11 for General Information.

② Reduced shank diameter hubs are available where required bore permits. See Table 32, page 50 for selection.

③ Peak torque capacity is two times the published rating.

④ Consult Factory for higher speeds. Balancing may allow up to a 50% increase in speeds shown.

⑤ Maximum bores are reduced for hubs furnished with an interference fit and a setscrew over the keyway. Refer to Table 13 and Table 14, page 43. Bore capacities can be increased beyond values shown if the coupling torque rating is reduced. Refer to the Factory. Recommended key sizes for the listed maximum bores are shown in Table 35, page 52, and Table 23, page 47.

⑥ Minimum bore is the smallest bore to which a Rough Stock Bore (RSB) hub can be bored. Depending upon coupling size, RSB hubs may have only a blind centering hole or a through hole that will permit remachining of the hubs to the minimum bores specified.

# Type GV52 Large Flanged Sleeve Vertical Single Engagement

**IMPORTANT:** When couplings are mounted on a floating shaft, do not exceed allowable shaft speed for the assembly.

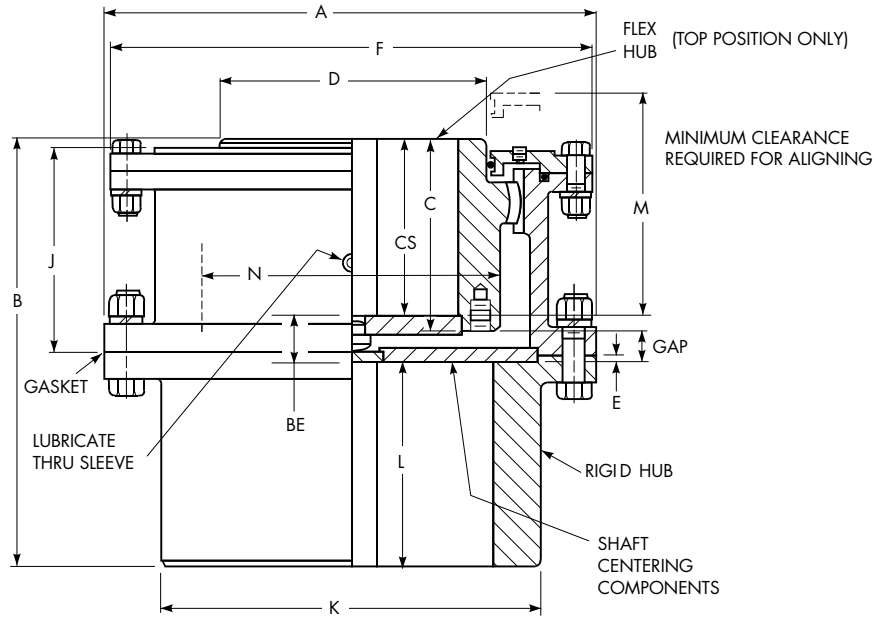

## Dimensions (mm)

Size ①	Torque Rating (Nm – millions) ④		Allow Speed RPM ⑤	Max Bore One Rect Key ②		Min Bore Both Hubs ⑥	Cplg Wt with No Bore (kg) ⑥	Lube Wt (kg) ⑥	A	B	C	D	E	F	J	K ③	L	M	N	BE	CS	GAP
	1000 Series	2000 Series		Flex Hub	Rigid Hub																	
1080/2080G	0,170	0,234	1750	266	340	101,60	699	4,99	590,6	511,6	236,7	355,6	8,1	571,5	242,8	450,8	248,9	287,3	368,3	38,6	224,0	26
1090/2090G	0,226	0,315	1550	290	380	114,30	984	6,35	660,4	567,2	261,9	393,7	8,1	641,4	265,2	508,0	275,8	314,5	419,1	42,2	249,2	29
1100/2100G	0,310	0,443	1450	320	400	127,00	1252	7,71	711,2	625,3	288,8	444,5	9,7	698,5	293,6	530,4	304,8	339,9	469,9	48,3	273,1	33
1110/2110G	0,413	0,609	1330	373	440	139,70	1637	9,07	774,7	682,8	317,2	495,3	9,7	749,3	322,3	584,2	333,2	368,3	520,7	48,3	301,5	33
1120/2120G	0,555	0,777	1200	400	483	152,40	2077	10,9	838,2	721,4	336,6	546,1	9,7	825,5	341,4	647,7	352,3	387,4	571,5	48,3	320,8	33
1130/2130G	0,719	0,925	1075	440	500	165,10	2572	16,8	911,4	762,0	352,0	584,2	9,7	886,0	362,0	708,2	371,3	419,1	609,6	54,9	336,3	39
1140/2140G	0,911	1,140	920	460	535	177,80	3062	17,2	965,2	806,4	373,9	635,0	9,7	939,8	378,0	749,3	393,7	441,5	660,4	54,9	358,1	39
1150/2150G	1,100	1,350	770	490	580	190,50	3751	20,9	1 028,7	857,2	399,8	685,8	9,7	1 003,3	407,9	812,8	419,1	466,9	711,2	54,9	384,0	39
1160/2160G	1,310	1,640	650	525 ⊗	630 ⊗	254,00	4631	21,8	1 111,2	908,0	416,1	736,6	12,7	1 085,8	419,1	886,0 ⊗	441,5	482,6	762,0 ⊗	70,4	397,0	51
1180/2180G	1,660	2,140	480	600 ⊗	710 ⊗	285,75	6069	25,4	1 219,2	939,8	431,8	838,2	12,7	1 193,8	434,8	993,6 ⊗	457,2	501,6	863,6 ⊗	70,4	412,8	51
1200/2200G	2,140	2,850	370	660 ⊗	780 ⊗	317,50	8482	34,5	1 358,9	1 098,6	511,0	927,1	12,7	1 308,1	514,4	1 095,2 ⊗	536,4	616,0	965,2 ⊗	70,4	492,3	51
1220/2220G	2,720	3,560	290	725 ⊗	890 ⊗	349,25	11 680	54,4	1 511,3	1 196,8	555,8	1 016,0	15,7	1 473,2	565,2	1 244,6 ⊗	584,2	660,4	1 066,8 ⊗	83,3	530,4	58
1240/2240G	3,470	4,480	270	810 ⊗	940 ⊗	381,00	14 388	56,7	1 632,0	1 285,7	599,9	1 130,3	15,7	1 581,2	606,6	1 314,7 ⊗	628,6	698,5	1 168,4 ⊗	83,3	574,5	58
1260/2260G	4,490	5,480	250	880 ⊗	1 015 ⊗	412,75	17 722	61,2	1 746,2	1 374,6	644,7	1 231,9	15,7	1 695,4	647,7	1 422,4 ⊗	673,1	749,3	1 270,0 ⊗	83,1	619,3	58
1280/2280G	5,840	6,760	230	950 ⊗	1 090 ⊗	444,50	21 110	70,3	1 866,9	1 412,7	663,4	1 333,5	15,7	1 803,4	666,8	1 530,6 ⊗	691,9	768,4	1 371,6 ⊗	83,1	638,0	58
1300/2300G	6,760	8,190	220	1 025 ⊗	1 170 ⊗	476,25	24 712	77,1	1 974,8	1 450,8	682,8	1 435,1	15,7	1 911,4	685,8	1 638,3 ⊗	711,2	774,7	1 473,2 ⊗	83,1	657,4	58

① See page 11 for General Information. Downward thrust capacity of lower supporting button for Sizes 1080 and larger is 39 463 kilograms.

② Reduced shank diameter hubs are available where required bore permits. See Table 32, page 50 for selection.

③ Dimension K may be an "as-cast" surface, depending upon coupling size and bore.

④ Peak torque capacity is two times the published rating.

⑤ Consult Factory for higher speeds. Balancing may allow up to a 50% increase in speeds shown.

⑥ Minimum bore is the smallest bore to which a Rough Stock Bore (RSB) hub can be bored. Depending upon coupling size, RSB hubs may have only a blind centering hole or a through hole that will permit remachining of the hubs to the minimum bores specified.

# Type GL20-4 Large Flanged Sleeve Slide Double Engagement

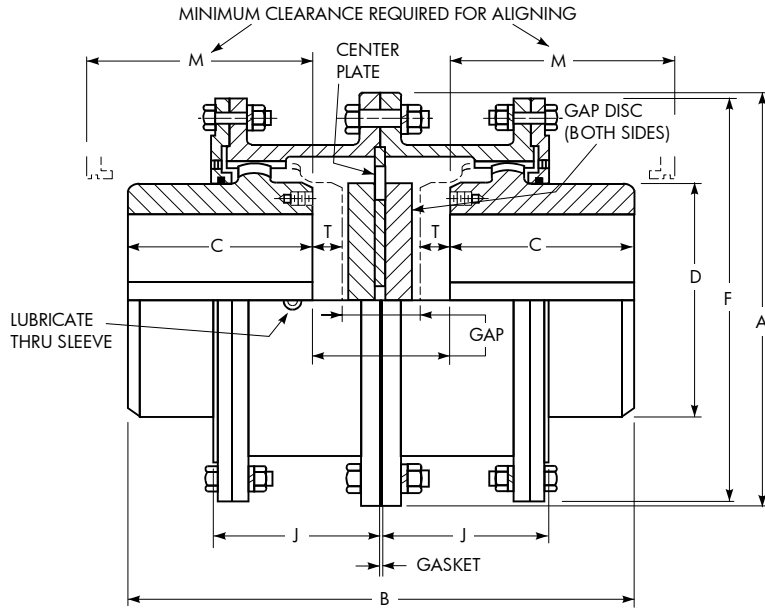

## Dimensions (mm)

Size ①	Torque Rating (Nm – millions) ②		Allow Speed RPM ③	Max Bore One Rect Key ④	Min Bore ⑤	Cplg Wt with No Bore (kg)	Lube Wt (kg)	A	B Max	C	D	F	J	M	T (Max)		GAP	
	1000 Series	2000 Series													Each	Total	Min	Max
1080/2080GL	0,170	0,234	1160	266	101,60	685	9,53	590,6	740,2	249,4	355,6	571,5	242,8	300,0	14,0	27,9	213	241
1090/2090GL	0,226	0,315	1030	290	114,30	943	12,2	660,4	793,0	276,4	393,7	641,4	265,2	327,2	22,9	45,7	195	240
1100/2100GL	0,310	0,443	960	320	127,00	1 247	15,0	711,2	893,6	304,8	444,5	698,5	293,6	355,6	21,1	42,2	242	284
1110/2110GL	0,413	0,609	880	373	139,70	1 610	17,7	774,7	994,2	333,2	495,3	749,3	322,3	384,0	19,0	38,1	290	328
1120/2120GL	0,555	0,777	800	400	152,40	2 037	20,9	838,2	1 061,2	352,6	546,1	825,5	341,4	403,4	19,0	38,1	318	356

① See **page 11** for General Information.

② Peak torque capacity is two times the published rating.

③ Consult Factory for higher speeds. Balancing may allow up to a 50% increase in speeds shown.

④ Maximum bores are reduced for hubs furnished with an interference fit and a setscrew over the keyway. Refer to **Table 13 and Table 14, page 43**. Bore capacities can be increased beyond values shown if the coupling torque rating is reduced. Refer to the Factory. Recommended key sizes for the listed maximum bores are shown in **Table 35, page 52, and Table 23, page 47**.

⑤ Minimum bore is the smallest bore to which a Rough Stock Bore (RSB) hub can be bored. Depending upon coupling size, RSB hubs may have only a blind centering hole or a through hole that will permit remachining of the hubs to the minimum bores specified.

# Type G70 Large Disconnect

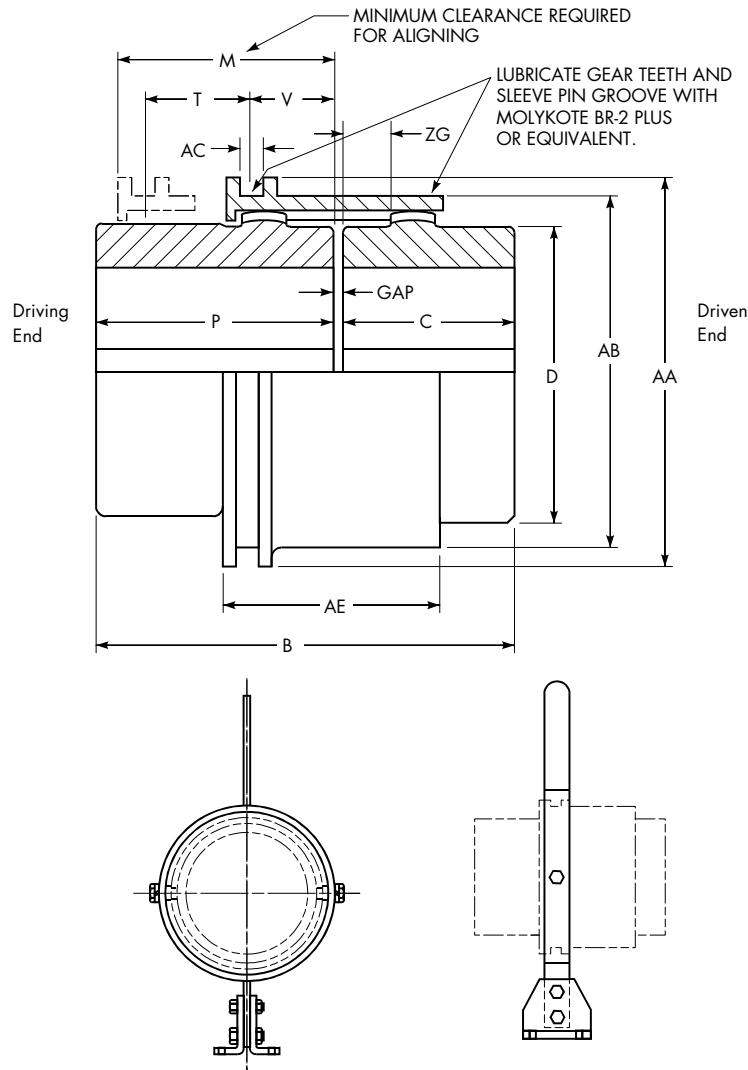

Optional hand-operated shifter mechanism to shift and secure the proper position of the sleeve assembly.

## Dimensions (mm)

Size <sup>①</sup>	Torque Rating (Nm – millions) <sup>②</sup>	Allow Speed RPM <sup>③</sup>	Max Bore One Rect Key <sup>④</sup>	Min Bore <sup>⑤</sup>	Cplg Wt with No Bore (kg)	B	C	D	M	P	T	V	AA	AB	AC	AE	ZG	GAP
1080G	0,170	110	266	102	498	508,0	249,4	368,3	228,6	249,4	108,2	88,4	491,7	461,3	19,3	215,9	41,4	10
1090G	0,226	100	290	114	698	559,3	276,4	419,1	263,7	270,3	130,6	95,0	556,3	515,6	25,4	251,0	52,8	13
1100G	0,310	90	320	127	956	622,3	304,8	469,9	283,0	304,8	137,2	107,7	607,1	566,4	25,4	270,3	52,8	13
1110G	0,413	80	373	140	1256	679,2	333,2	520,7	296,2	333,2	143,8	114,3	655,3	614,7	25,4	283,5	52,8	13
1120G	0,555	75	400	152	1559	702,6	352,6	571,5	292,1	337,3	149,4	104,6	711,2	670,6	25,4	279,4	52,3	13
1130G	0,719	70	440	165	1779	697,0	338,8	609,6	288,5	338,8	141,7	102,6	778,3	727,5	31,5	275,8	32,0	19
1140G	0,911	65	460	178	2127	719,3	350,0	660,4	288,5	350,0	141,7	102,6	828,0	777,2	31,5	275,8	26,9	19
1150G	1,100	60	490	190	2623	770,1	375,4	711,2	288,5	375,4	141,7	102,6	882,4	831,6	31,5	275,8	21,3	19

① See page 11 for General Information.

② Peak torque capacity is two times the published rating.

③ Consult Factory for higher speeds. Balancing may allow up to a 50% increase in speeds shown.

④ Maximum bores are reduced for hubs furnished with an interference fit and a setscrew over the keyway. Refer to **Table 13 and Table 14, page 43**. Bore capacities can be increased beyond values shown if the coupling torque rating is reduced. Refer to the Factory. Recommended key sizes for the listed maximum bores are shown in **Table 35, page 52, and Table 23, page 47**.

⑤ Minimum bore is the smallest bore to which a Rough Stock Bore (RSB) hub can be bored. Depending upon coupling size, RSB hubs may have only a blind centering hole or a through hole that will permit remachining of the hubs to the minimum bores specified.

# Type G82 Large Flanged Sleeve Rigid

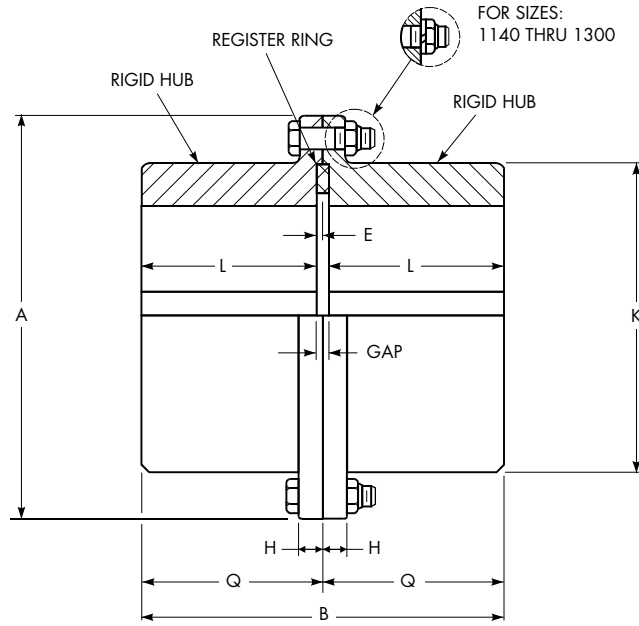

## Dimensions (mm)

Size ①	Torque Rating (Nm – millions) ④	Allow Speed RPM ⑤	Max Bore One Rect Key ⑥	Min Bore ⑦	Cplg Wt with No Bore (kg)	A	B	E	H	K ③	L	Q	GAP
1080G	0,170	1,750	340	102	699	590,6	514,1	8,1	31,5	450,8	248,9	257,0	16
1090G	0,226	1,550	380	114	984	660,4	567,9	8,1	38,1	508,0	275,8	284,0	16
1100G	0,310	1,450	400	127	1207	711,2	628,9	9,7	44,2	530,4	304,8	314,5	19
1110G	0,413	1,330	440	140	1601	774,7	685,8	9,7	50,8	584,2	333,2	342,9	19
1120G	0,555	1,200	483	152	2050	838,2	723,9	9,7	53,8	647,7	352,3	362,0	19
1130G	0,719	1,075	500	165	2558	911,4	762,0	9,7	53,8	708,2	371,3	381,0	19
1140G	0,911	920	535	178	3030	965,2	806,7	9,7	53,8	749,3	393,7	403,4	19
1150G	1,100	770	580	191	3747	1028,7	857,5	9,7	53,8	812,8	419,1	428,8	19
1160G	1,310	650	630 Ⓣ	254	4681	1111,3	908,3	12,7	57,2	886,0 Ⓣ	441,5	454,2	25
1180G	1,660	480	710 Ⓣ	286	6024	1219,2	929,8	12,7	57,2	993,6 Ⓣ	457,2	469,9	25
1200G	2,140	370	780 Ⓣ	318	8573	1358,9	1098,3	12,7	63,5	1095,2 Ⓣ	536,4	549,1	25
1220G	2,720	290	890 Ⓣ	350	11893	1511,3	1199,9	15,7	63,5	1244,6 Ⓣ	584,2	599,9	31
1240G	3,470	270	940 Ⓣ	381	14524	1632,0	1289,3	15,7	76,2	1314,7 Ⓣ	628,9	644,7	31
1260G	4,490	250	1015 Ⓣ	413	18035	1746,3	1377,7	15,7	76,2	1422,4 Ⓣ	673,1	688,8	31
1280G	5,840	230	1090 Ⓣ	445	21473	1866,9	1415,3	15,7	82,3	1530,6 Ⓣ	691,9	707,6	31
1300G	6,760	220	1170 Ⓣ	477	25124	1974,9	1453,9	15,7	82,3	1638,3 Ⓣ	711,2	726,9	31

① See page 11 for General Information.

② Dimension K may be an “as-cast” surface, depending upon coupling size and bore.

③ For standard shank diameter hubs.

④ Peak torque capacity is two times the published rating.

⑤ Consult Factory for higher speeds. Balancing may allow up to a 50% increase in speeds shown.

⑥ Maximum bores are reduced for hubs furnished with an interference fit and a setscrew over the keyway. Refer to **Table 13 and Table 14, page 43**. Bore capacities can be increased beyond values shown if the coupling torque rating is reduced. Refer to the Factory. Recommended key sizes for the listed maximum bores are shown in **Table 35, page 52, and Table 23, page 47**.

⑦ Minimum bore is the smallest bore to which a Rough Stock Bore (RSB) hub can be bored. Depending upon coupling size, RSB hubs may have only a blind centering hole or a through hole that will permit remachining of the hubs to the minimum bores specified.

## Type GR20 Large Flanged Sleeve Shear/Pin Double Engagement

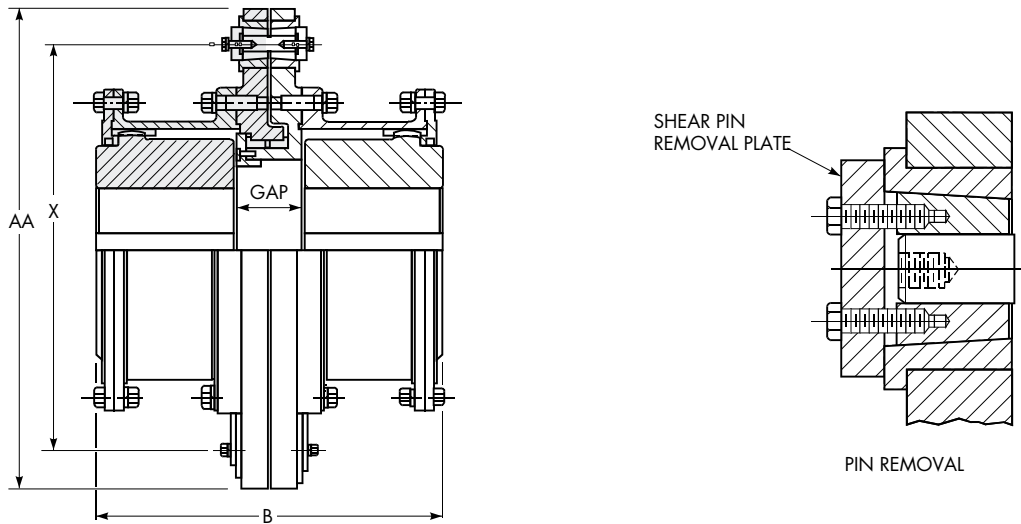

### Dimensions (mm)

Size ①	1000 Series Shear Torque (Nm x 10 <sup>6</sup> )		2000 Series Shear Torque (Nm x 10 <sup>6</sup> )		Allow Speed RPM ②	Max Bore One Rect Key ③	Min Bore ④	Approximate Values			
	Min	Max	Min	Max				AA	X	Gap	B
1080/2080GR	0,052	0,235	0,081	0,366	880	266	101,6	990,6	812,8	121	619,8
1090/2090GR	0,071	0,319	0,107	0,495	780	290	114,3	1 066,8	889,0	127	679,7
1100/2100GR	0,099	0,449	0,156	0,696	730	320	127,0	1 117,6	939,8	146	755,9
1110/2110GR	0,137	0,617	0,215	0,960	670	373	139,7	1 168,4	990,6	165	831,6
1120/2120GR	0,176	0,795	0,271	1,22	600	400	152,4	1 244,6	1 066,8	178	882,9
1130/2130GR	0,216	0,983	0,327	1,47	540	440	165,1	1 346,2	1 143,0	184	927,1
1140/2140GR	0,258	1,16	0,403	1,82	460	460	177,8	1 409,7	1 193,8	197	984,5
1150/2150GR	0,299	1,34	0,460	2,07	390	490	190,5	1 485,9	1 257,3	203	1 041,4
1160/2160GR	0,384	1,71	0,571	2,57	330	525	254,0	1 600,2	1 346,2	229	1 111,5
1180/2180GR	0,498	2,23	0,747	3,35	240	600	285,8	1 651,0	1 447,8	241	1 155,7
1200/2200GR	0,647	3,02	1,00	4,47	190	660	317,5	1 803,4	1 600,2	261	1 333,5
1220/2220GR	0,847	3,80	1,25	5,59	150	725	349,2	1 930,4	1 727,2	273	1 441,7
1240/2240GR	1,05	4,69	1,57	7,04	140	810	381,0	2 057,4	1 854,2	305	1 562,1
1260/2260GR	1,29	5,81	1,92	8,60	130	880	412,8	2 184,4	1 981,2	324	1 670,3
1280/2280GR	1,54	6,93	2,37	10,62	120	950	444,5	2 311,4	2 108,2	337	1 721,1
1300/2300GR	1,87	8,38	2,87	12,85	110	1 025	476,2	2 413,0	2 209,8	362	1 784,6

① See page 11 for General Information.

② Consult Factory for higher speeds. Balancing may allow up to a 50% increase in speeds shown.

③ Maximum bores are reduced for hubs furnished with an interference fit and a setscrew over the keyway. Refer to Table 13 and Table 14, page 43. Bore capacities can be increased beyond values shown if the coupling torque rating is reduced. Refer to the Factory. Recommended key sizes for the listed maximum bores are shown in Table 35, page 52, and Table 23, page 47.

④ Minimum bore is the smallest bore to which a Rough Stock Bore (RSB) hub can be bored. Depending upon coupling size, RSB hubs may have only a blind centering hole or a through hole that will permit remachining of the hubs to the minimum bores specified.

## Engineering Data — Standard Flanged Sleeve & Continuous Sleeve

Table 12 — Shaft Diameters & Ratings for NEMA 60 Hertz & 50 Hertz Metric Motors

Frame Size		NEMA 60 Hertz Motors (HP)																	
		T Frames																	
		143	145	182	184	213	215	254	256	284	286	324	326	364	365	404	405	444	445
Shaft	Diameter	0.88	0.88	1.13	1.13	1.38	1.38	1.63	1.63	1.88	1.88	2.13	2.13	2.38	2.38	2.88	2.88	3.38	3.38
3600 RPM	Drip Proof	1-1/2	2-3	5	7-1/2	10	15	20	25	30	40	50	60	75	100	125	150	200	250
	Enclosed	1-1/2	2	3	5	7-1/2	10	15	20	25	30	40	50	60	75	—	100	125	150
1800 RPM	Drip Proof	1	1-1/2-2	3	5	7-1/2	10	15	20	25	30	40	50	60	75	100	125	150	200
	Enclosed	1	1-1/2-2	3	5	7-1/2	10	15	20	25	30	40	50	60	75	—	100	125	150
1200 RPM	Drip Proof & Enclosed	3/4	1	1-1/2	2	3	5	7-1/2	10	15	20	25	30	40	50	60	75	100	125
900 RPM	Drip Proof & Enclosed	1/2	3/4	1	1-1/2	2	3	5	7-1/2	10	15	20	25	30	40	50	60	75	100

Frame Size		NEMA 60 Hertz Motors (HP)									
		TS Frames									
		284	286	324	326	364	365	404	405	444	445
Shaft	Diameter	1.63	1.63	1.88	1.88	1.88	1.88	2.13	2.13	2.38	2.38
3600 RPM	Drip Proof	30	40	50	60	75	100	125	150	200	250
	Enclosed	25	30	40	50	60	75	—	100	125	150
1800 RPM	Drip Proof	25	30	40	50	60	75	100	125	150	200
	Enclosed	25	30	40	50	60	75	—	100	125	150
1200 RPM	Drip Proof & Enclosed	15	20	25	30	40	50	60	75	100	125
900 RPM	Drip Proof & Enclosed	10	15	20	25	30	40	50	60	75	100

Frame Size		50 Hertz Metric Motors (kW)																	
		80	90S	90L	100L	112M	132S	132M	160M	160L	180M	180L	200M/L	225S	225M	250S	250M	280S	280M
Shaft Diameter		19	24	24	28	28	38	38	42	42	48	48	55	55	55	60.65	60.65	65, 75	65, 75
														60	60	70	70	80	80
3000 RPM	0.75	1.5	2.2	3.0	4	5.5	9.3	11	18.5	22	—	30	45	45	55	55	75	90	
	7.5					15		37				75				90	110		
1500 RPM	0.55	1.1	1.5	2.2	4	5.5	7.5	11	15	18.5	22	30	37	45	55	55	75	90	
	3.0			45									75			90	110		
1000 RPM	0.37	0.75	1.1	1.5	2.2	3	4	7.5	11	—	15	18.5	30	30	37	37	45	55	
	5.5						22					45				50	75		
750 RPM	0.18	0.37	0.55	0.75	1.5	2.2	3	4	7.5	—	11	15	18.5	22	30	30	37	45	
	1.1			5.5				37								45	55		

# Engineering Data — Standard Flanged Sleeve & Continuous Sleeve

**Table 13 — Type G & GC Flex/Pilot Hub Maximum Bores (mm/in)**

Size ①	Millimeters — Fits Per Table 12				Inches										
	Min Bore ④	Max Bore ③			With One Square Key			With One Rectangular Key					Max Bore ③		
		Std Bore Fits per Table 15	Int Fit w/ Set Screw Over Keyway	With Puller Holes per Table 17	Max Bore ③	Y=X		Max Bore ③	Y=X		Max Bore ③	Y=W/2		Int Fit w/ Set Screw Over Keyway	With Puller Holes per Table 17
						W	X		W	X		W	X		
1010G/GC	13	50	45	38	1.875 Ⓣ	0.500	0.250	2.000	0.500	0.187	2.125	0.500	0.125	1.750	1.500
1015G/GC	20	65	60	54	2.375 Ⓣ	0.625	0.312	2.500	0.625	0.218	2.750	0.625	0.125	2.250	2.125
1020G/GC	26	78	75	72	2.875 Ⓣ	0.750	0.375	3.125	0.750	0.250	3.250	0.750	0.125	2.750	2.875
1025G/GC	32	98	88	92	3.625 Ⓣ	0.875	0.437	3.875	1.000	0.375	4.000	1.000	0.250	3.250	3.625
1030G/GC	39	111	101	104	4.125 Ⓣ	1.000	0.500	4.375	1.000	0.375	4.750	1.250	0.250	3.750	4.125
1035G/GC	51	134	121	124	4.875 Ⓣ	1.250	0.625	5.250	1.250	0.437	5.750	1.500	0.250	4.500	4.875
1040G	64	160	150	146	5.750 Ⓣ	1.500	0.750	6.250	1.500	0.500	6.500	1.500	0.250	5.500	5.750
1045G	77	183	160	171	6.500	1.500	0.750	6.750 Ⓣ	1.750	0.750	—	—	—	5.750	6.750
1050G	89	200	177	187	7.000	1.750	0.875	7.375 Ⓣ	1.750	0.750	—	—	—	6.500	7.375
1055G	102	220	200	209	7.750	2.000	1.000	8.250 Ⓣ	2.000	0.750	—	—	—	7.500	8.250
1060G	115	244	212	232	8.750	2.000	1.000	9.125 Ⓣ	2.500	0.875	—	—	—	8.000	9.125
1070G	127	289	235	276	10.000	2.500	1.250	10.875 Ⓣ	2.500	0.875	—	—	—	9.000	10.875

**Table 14 — Type G & GC Rigid Hub & Maximum Bores (mm/in)**

Size ①	Millimeters — Fits Per Table 12				Inches										
	Min Bore ④	Max Bore ③			With One Square Key			With One Rectangular Key					Max Bore ③		
		Std Bore Fits per Table 15	Int Fit w/ Set Screw Over Keyway	With Puller Holes per Table 17	Max Bore ③	Y=X		Max Bore ③	Y=X		Max Bore ③	Y=W/2		Int Fit w/ Set Screw Over Keyway	With Puller Holes per Table 17
						W	X		W	X		W	X		
1010G	13	65	60	51	2.375 Ⓣ	0.625	0.312	2.500	0.625	0.218	2.750	0.625	0.125	2.250	2.000
1015G	20	80	75	70	2.937 Ⓣ	0.750	0.375	3.250	0.750	0.250	3.375	0.875	0.187	2.750	2.750
1020G	26	98	88	92	3.625 Ⓣ	0.875	0.437	3.875	1.000	0.375	4.000	1.000	0.250	3.250	3.625
1025G	32	118	107	111	4.375 Ⓣ	1.000	0.500	4.625	1.250	0.437	4.875	1.250	0.250	3.875	4.375
1030G	39	140	121	130	5.125 Ⓣ	1.250	0.625	5.500	1.250	0.437	5.875	1.500	0.250	4.500	5.125
1035G	51	163	150	150	5.875 Ⓣ	1.500	0.750	6.500	1.500	0.500	—	—	—	5.500	5.875
1040G	64	196	167	185	6.750	1.750	0.875	7.250 Ⓣ	1.750	0.750	—	—	—	6.000	7.250
1045G	77	216	190	205	7.625	1.750	0.875	8.125 Ⓣ	2.000	0.750	—	—	—	7.000	8.125
1050G	89	235	220	228	8.750	2.000	1.000	9.000 Ⓣ	2.000	0.750	—	—	—	8.250	9.000
1055G	102	266	230	250	9.750	2.000	1.000	10.000 Ⓣ	2.500	0.875	—	—	—	8.750	10.000
1060G	115	290	260	280	10.500	2.500	1.250	11.000 Ⓣ	2.500	0.875	—	—	—	9.750	11.000
1070G	127	340	290	330	12.000	3.000	1.500	13.000 Ⓣ	3.000	1.000	—	—	—	11.000	13.000

① See page 11 for General Information.

② Maximum bores for standard keys recommended in Table 34.

③ Maximum bores are reduced for hubs furnished with an interference fit and a setscrew over the keyway. Maximum bores may also be reduced when puller bolt holes are required. Refer to Table 13 and Table 14, page 43. Bore capacities can be increased beyond values shown if the coupling torque rating is reduced. Refer to the Factory. Recommended key sizes for the listed maximum bores are shown in Table 34, page 51, and Table 23, page 47.

④ Minimum bore is the smallest bore to which a Rough Stock Bore (RSB) hub can be bored. Depending upon coupling size, RSB hubs may have only a blind centering hole or a through hole that will permit remachining of the hubs to the minimum bores specified.

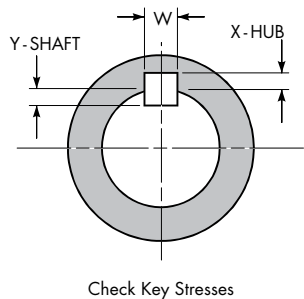
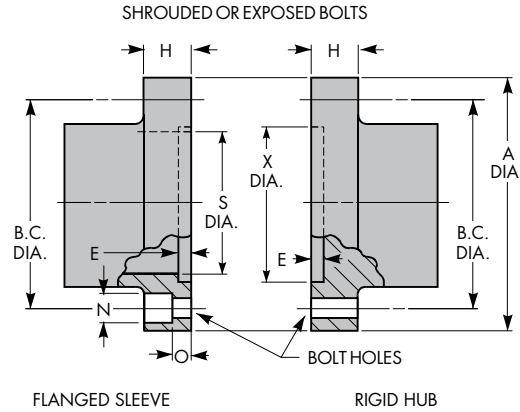

**Table 15 — Recommended Bore Tolerances Rexnord Steel Coupling Hubs (mm)**

Shaft Diameter (ISO/R775-1969)		Bore Diameter Tolerance		
Nominal	Tolerance	Clearance	Transitional	Interference
6 to 30	j6/k6 Ⓣ	F7	H7	M6
Over 30 to 50	k6	F7	H7	K6
Over 50 to 80	m6	F7	H7	K7
Over 80 to 100	m6	F7	H7	M7
Over 100 to 200	m6	F7	H7	P7
Over 200 to 355	m6	F7	H7	R7
Over 355 to 500	m6	F7	H7	R8

Ⓣ Per DIN 748 — Differs with ISO/R775.

# Engineering Data — Standard Flanged Sleeve & Continuous Sleeve

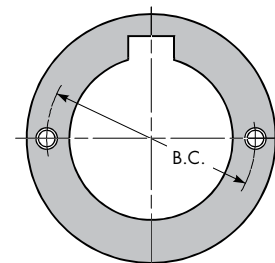

**Table 16 — Flanged Sleeve and Rigid Hub Details (mm)**

Size ①	Shrouded or Exposed Bolts					Shrouded				Exposed	
	A + 0,000 - 0,010	E ± 0,25	H	S ± 0,25	X ± 0,25	B.C.	Bolt No.-Dia (in)	N	O	B.C.	Bolt No.-Dia (in)
1010G	115,87	2,54	14,0	77,72	80,77	95,25	6- .250	11,7	6,35	95,25	6- .250
1015G	152,40	2,54	19,0	96,77	99,57	122,22	8- .375	14,7	6,35	122,22	8- .375
1020G	177,80	2,54	19,0	117,86	121,92	147,62	10- .375	14,7	6,35	149,23	6- .500
1025G	212,73	2,54	19,0	144,78	148,84	177,80	10- .500	19,8	8,13	180,98	6- .625
1030G	239,73	2,54	21,8	169,16	173,22	203,20	12- .500	19,8	8,13	206,38	8- .625
1035G	279,40	2,54	21,8	195,33	199,64	235,74	12- .625	24,6	10,16	241,30	8- .750
1040G	317,50	4,06	28,4	230,12	234,95	269,88	14- .625	24,6	10,16	279,40	8- .750
1045G	346,08	4,06	28,4	255,52	260,35	298,45	14- .625	24,6	10,16	304,80	10- .750
1050G	388,95	5,08	38,1	280,92	390,07	334,98	14- .750	29,5	14,22	342,90	8- .875
1055G	425,45	5,08	38,1	307,09	315,47	366,73	16- .750	29,5	14,22	368,30	14- .875
1060G	457,20	6,60	25,4	337,31	353,57	—	—	—	—	400,05	14- .875
1070G	527,05	8,38	28,4	388,62	404,88	—	—	—	—	463,55	16- 1.00

**Table 17 — Puller Bolt Holes (Conforms to API 610 Specifications) (mm)**

Size ①	B.C.		Tap Size UNC
	Flex Hub/Pilot Hub	Rigid Hub	
1010G/GC ②	52,32	66,68	M10 x 1,5 x 13
1015G/GC ②	69,85	85,73	M10 x 1,5 x 13
1020G/GC	88,90	107,95	M10 x 1,5 x 13
1025G/GC	112,78	133,10	M10 x 1,5 x 13
1030G/GC	128,52	156,46	M10 x 1,5 x 13
1035G/GC	152,40	182,37	M12 x 1,75 x 16
1040G	180,98	209,80	M16 x 2,0 x 20
1045G	200,03	233,17	M16 x 2,0 x 20
1050G	215,90	259,08	M20 x 2,5 x 22
1055G	238,13	284,48	M20 x 2,5 x 22
1060G	263,53	316,48	M20 x 2,5 x 22
1070G	311,15	368,30	M24 x 3,0 x 30



Puller bolt holes are available for an extra charge.

① See page 11 for General Information.

② See Table 13 and Table 14, page 43 for maximum bore limitations.

# Engineering Data — Standard Flanged Sleeve & Continuous Sleeve

**Table 18 — Torsional Stiffness—Nm/Radian (10<sup>6</sup>) with No Bores**

Size ①	Exposed Bolt Types				Shrouded Bolt Types				Continuous Sleeves	
	Half Couplings		Complete Couplings		Half Couplings		Complete Couplings		GC02	GC05
	Flex Half	Rigid Half	G20 GP20	G52 GP52	Flex Hub	Rigid Hub	G10	G51		
1010G/GC	4,7	10,3	2,4	3,2	3,2	9,5	1,6	2,4	3,3	3,2
1015G/GC	12,1	24,1	6,0	8,0	8,9	21,2	4,4	6,2	6,8	6,7
1020G/GC	18,3	39,4	9,2	12,4	14,5	35,8	7,2	10,3	11,6	11,5
1025G/GC	27,8	69,0	13,9	20,0	22,3	62,9	11,2	16,5	21,9	22,0
1030G/GC	40,1	103,0	20,0	28,8	33,1	95,8	16,5	24,6	34,3	34,6
1035G/GC	53,0	169,6	26,4	40,3	56,0	154,9	28,0	41,1	48,9	49,9
1040G	108,8	268,5	54,3	77,4	78,9	241,6	39,4	59,4	—	—
1045G	138,2	355,2	69,0	99,4	114,9	332,4	57,4	85,4	—	—
1050G	222,1	477,5	111,1	151,6	177,7	457,8	88,8	128,0	—	—
1055G	244,9	607,3	122,4	175,6	220,8	564,3	110,4	158,6	—	—
1060G	292,4	743,9	146,2	209,8	—	—	—	—	—	—
1070G	483,1	1152,7	241,6	340,4	—	—	—	—	—	—

**Table 19 — WR<sup>2</sup> (Kgm<sup>2</sup>) Values with No Bores**

Size ①	Type G and GP											Type GL		Type GV				Type GC	
	G10	G20 GP20	G32 ②		Spacer WR <sup>2</sup> per mm ③	G51	G52 GP52	G70	G72	G81	G82 GP82 GV82	GL20	GL52	GV10	GV20	GV51	GV52	GC02	GC05
			Min BE	Cplg. WR <sup>2</sup>															
1010G/GC	0,0047	0,0056	82,55	0,0102	0,0004	0,0050	0,0059	0,0032	0,0061	0,0050	0,0059	0,0059	0,0059	0,0047	0,0056	0,0050	0,0059	0,0030	0,0030
1015G/GC	0,0161	0,0205	82,55	0,0366	0,0005	0,0164	0,0208	0,0085	0,0225	0,0167	0,214	0,0211	0,0211	0,0158	0,0202	0,0167	0,0211	0,0085	0,0088
1020G/GC	0,0360	0,0439	82,55	0,0717	0,0012	0,0380	0,0454	0,0234	0,0497	0,0395	0,0468	0,454	0,0454	0,0366	0,0424	0,0380	0,0468	0,0225	0,0234
1025G/GC	0,0884	0,1127	95,25	0,1785	0,0023	0,0936	0,1170	0,0614	0,1244	0,0995	0,1229	0,1156	0,1185	0,0892	0,1127	0,0951	0,1185	0,0644	0,0658
1030G/GC	0,1697	0,2063	95,25	0,3175	0,0034	0,1814	0,2180	0,1317	0,2341	0,1931	0,2297	0,2165	0,2224	0,1697	0,2063	0,1829	0,2195	0,1369	0,1399
1035G/GC	0,3862	0,4755	120,65	0,7300	0,0078	0,4067	0,4960	0,2750	0,5208	0,4213	0,5164	0,4930	0,5033	0,3833	0,4725	0,4053	0,4989	0,2663	0,2712
1040G	0,7593	0,9085	120,65	1,32	0,0144	0,8003	0,9510	0,5764	0,9817	0,8339	0,9948	0,9539	0,9656	0,7549	0,9041	0,8047	0,9612	—	—
1045G	1,24	1,47	146,05	2,07	0,0258	1,31	1,52	1,01	1,51	1,37	1,57	1,54	1,54	1,23	1,46	1,32	1,53	—	—
1050G	2,20	2,63	146,05	3,87	0,0351	2,35	2,79	1,64	2,78	2,50	2,94	2,76	2,83	2,21	2,64	2,39	2,82	—	—
1055G	3,65	4,03	146,05	5,78	0,0465	3,97	4,39	2,40	4,18	4,28	4,74	4,23	4,45	3,65	4,04	4,01	4,44	—	—
1060G	—	5,33	146,05	6,61	0,0661	—	5,79	3,96	6,09	—	6,25	5,69	5,91	—	5,37	—	5,90	—	—
1070G	—	11,3	146,05	14,8	0,0971	—	12,3	8,29	11,8	—	13,3	12,0	12,5	—	11,4	—	12,5	—	—

① See page 11 for General Information.

② To determine total WR<sup>2</sup> of spacer couplings with a BE (distance between shaft ends) greater than minimum:

1. Subtract minimum BE from required BE.

2. Multiply the result of Step 1 by the appropriate spacer WR<sup>2</sup> and add to coupling WR<sup>2</sup> at minimum BE.

③ Values apply to the tube portion only. Flange WR<sup>2</sup> is included in the spacer WR<sup>2</sup> for minimum BE.

**Table 20 — Standard Filleted Keyways & Chamfered Keys (mm) (Per ISO R773 Standard)**

Nominal		Size (Nominal)	Key		Width	Hub Keyway			
Over	Thru		Chamfer			Depth (T <sub>2</sub> ) ④		Fillet Radius	
			Minimum	Maximum		Minimum	Maximum	Minimum	Maximum
12	17	5 x 5	0,25	0,40	5	2,3	2,4	0,16	0,25
17	22	6 x 6	0,25	0,40	6	2,8	2,9	0,16	0,25
22	30	8 x 7	0,25	0,40	8	3,3	3,5	0,16	0,25
30	38	10 x 8	0,40	0,60	10	3,3	3,5	0,25	0,40
38	44	12 x 8	0,40	0,60	12	3,3	3,5	0,25	0,40
44	50	14 x 9	0,40	0,60	14	3,8	4,0	0,25	0,40
50	58	16 x 10	0,40	0,60	16	4,3	4,5	0,25	0,40
58	65	18 x 11	0,40	0,60	18	4,4	4,6	0,25	0,40
65	75	20 x 12	0,60	0,80	20	4,9	5,1	0,40	0,60
75	85	22 x 14	0,60	0,80	22	5,4	5,6	0,40	0,60
85	95	25 x 14	0,60	0,80	25	5,4	5,6	0,40	0,60
95	110	28 x 16	0,60	0,80	38	6,4	6,6	0,40	0,60
110	130	32 x 18	0,60	0,80	32	7,4	7,6	0,40	0,60
130	150	36 x 20	1,00	1,20	36	8,4	8,7	0,70	1,00
150	170	40 x 22	1,00	1,20	40	9,4	9,7	0,70	1,00
170	200	45 x 25	1,00	1,20	45	10,4	10,7	0,70	1,00
200	230	50 x 28	1,00	1,20	50	11,4	11,7	0,70	1,00
230	260	56 x 32	1,60	2,00	56	12,4	12,7	1,20	1,60
260	290	63 x 32	1,60	2,00	63	12,4	12,7	1,20	1,60
290	330	70 x 36	1,60	2,00	70	14,4	14,7	1,20	1,60

④ T<sub>2</sub> is from the top of the bore to the top of the hub keyway.

# Engineering Data — Standard Flanged Sleeve & Continuous Sleeve

**Variable Gap** — Normally it is not necessary to overhang gear coupling hubs since the hubs can readily be reversed to produce different gap dimensions as illustrated in **Figures 1, 2 and 4** below. Also, long hubs from **Table 10, page 32**, can be cut off to suit required gap as illustrated in **Figures 3 and 5** below.

However when the distance between shafts is greater than the allowable coupling gap, overhang one or both hubs. It must be remembered that this practice reduces shaft-hub engagement. If the overhang with a standard hub results in less than 0.75 times the shaft diameter engagement, a coupling with long hubs is recommended. Use the standard interference fit and check key strength.

**CAUTION:** The effect of open keyways on coupling balance should always be considered.

If axial shaft movement is required, use the Type GL slide coupling.

### Double Engagement Couplings

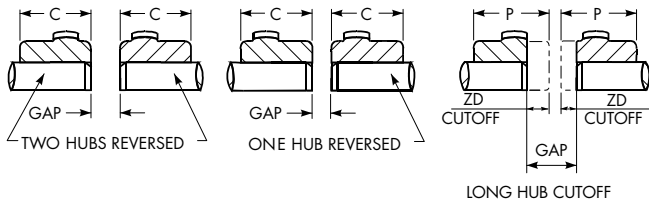

Figure 1

Figure 2

Figure 3

### Single Engagement Couplings

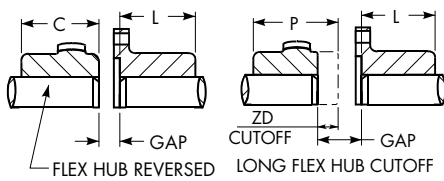

Figure 4

Figure 5

**Misalignment Capacity** — Shaft misalignment can be due to the combined effects of both parallel and angular shaft displacement. Falk 1000 Series gear couplings are designed to accommodate a static misalignment of 1-1/2° per gear mesh. The recommended installation misalignment is limited to 1/8° per gear mesh. Axial movement of connected shafts is also accommodated.

It is important that flexible couplings are properly aligned so that the maximum benefits of the equipment can be obtained. These benefits include the following:

1. Longer coupling life with minimum maintenance.
2. Longer life of the connected equipment as a result of reduced bending moments and radial forces which are related to the amount of misalignment.
3. Permit drive systems to have reserve misalignment capacity to accommodate unavoidable alignment changes caused by bearing wear foundation settling, thermal expansion, etc.

Dimension Y must be equal to or greater than Dimension X times 0.75. If not, use long hubs.

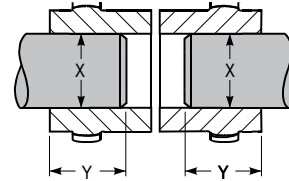

### Double Engagement

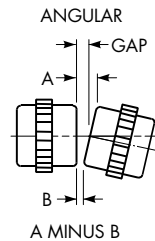

### Single Engagement

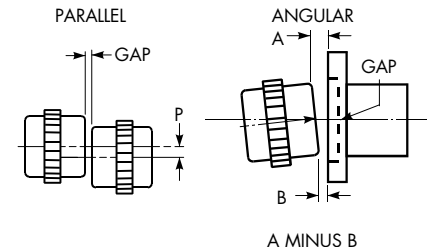

Table 21 — Type G Only Variable Gap (mm)

Size ①	C Std	L Std	P Max	ZG Max ②	Coupling Gap						
					Double Engagement			Single Engagement			
					Std	Fig 1	Fig 2	Fig 3	Std	Fig 4	Fig 5
1010G	42,9	39,6	101,6	18,5	3	10	7	40	4	8	23
1015G	49,3	46,2	114,3	25,4	3	29	16	54	4	17	29
1020G	62,0	58,4	130,0	29,5	3	27	15	62	4	16	33
1025G	77,0	73,7	149,4	36,3	5	34	19	77	5	19	41
1030G	91,2	87,9	165,1	44,4	5	45	25	94	5	25	49
1035G	106,4	102,1	184,2	54,1	6	61	34	115	6	33	60
1040G	120,6	115,3	203,2	63,8	6	61	43	134	7	44	71
1045G	134,9	130,6	244,3	70,4	8	86	47	149	8	47	78
1050G	153,2	147,3	295,1	81,8	8	102	55	172	9	56	91
1055G	168,1	172,7	298,4	95,8	8	134	71	199	9	72	105
1060G	188,2	186,4	304,8	102,1	8	127	68	212	10	70	112
1070G	220,7	220,2	309,9	120,1	10	150	80	250	13	83	133

① See page 11 for General Information.

② Standard gap must be increased by the amount cut off the hub, or hubs, to maintain the correct flex hub tooth position.

Table 22 — Misalignment Capacity (mm) ③

Size ①	Double Engagement				Single Engagement Angular Maximum ④	
	Recommended Installation Maximum		Maximum Operating ③		Recommended Installation A Minus B	Maximum Operating A Minus B ③
	Parallel Offset P	Angular A Minus B	Parallel Offset P	Angular A Minus B		
1010G	0,05	0,15	0,66	1,80	0,15	0,89
1010GC	0,04	0,08	0,28	1,80	0,15	0,89
1015G	0,08	0,18	0,86	2,26	0,18	1,14
1015GC	0,04	0,18	0,43	2,26	0,18	1,14
1020G	0,08	0,23	1,02	2,74	0,23	1,37
1020GC	0,04	0,23	0,48	2,74	0,23	1,37
1025G	0,10	0,28	1,27	3,43	0,28	1,70
1025GC	0,05	0,28	0,61	3,43	0,28	1,70
1030G	0,13	0,33	1,52	3,99	0,33	2,01
1030GC	0,05	0,33	0,69	3,99	0,33	2,01
1035G	0,15	0,38	1,83	4,65	0,38	2,34
1035GC	0,08	0,33	0,81	4,65	0,38	2,34
1040G	0,18	0,46	2,13	5,49	0,46	2,74
1045G	0,20	0,51	2,39	6,15	0,51	3,07
1050G	0,23	0,56	2,72	6,65	0,56	3,33
1055G	0,28	0,61	3,12	7,32	0,61	3,66
1060G	0,28	0,66	3,35	7,98	0,66	3,99
1070G	0,33	0,79	3,94	9,32	0,79	4,65

③ These maximum operating alignment limits are each based on 3/4° per flex half coupling. Combined values of parallel and angular misalignment should not exceed 3/4°. Type GL slide couplings are limited to 1/4° per flex half.

④ Do not use single engagement couplings to compensate for parallel offset misalignment.

# Engineering Data — Large Flanged Sleeve

**Table 23 — Recommended Commercial Keys for Bores with One & Two Keys (in) (Per ANSI B17.1 Standard)**

Shaft Diameter – Inches		One Key (in)	Shaft Diameter – Inches		Two Keys (in)
Over	Thru		Over	Thru	
3.750	4.500	1.000 x 1.000	9.000	10.500	1.500 x 1.000
4.500	5.500	1.250 x 1.250	10.500	12.000	1.750 x 1.500
5.500	6.500	1.500 x 1.500	12.000	13.500	2.000 x 1.500
6.500	7.500	1.750 x 1.500	13.500	16.000	2.500 x 1.750
7.500	9.000	2.000 x 1.500	16.000	19.500	3.000 x 2.000
9.000	11.000	2.500 x 1.750	19.500	23.000	3.500 x 2.500
11.000	13.000	3.000 x 2.000	23.000	28.000	4.000 x 3.000
13.000	15.000	3.500 x 2.500	28.000	34.000	5.000 x 3.500
15.000	18.000	4.000 x 3.000	34.000	41.000	6.000 x 4.000
18.000	22.000	5.000 x 3.500	41.000	49.000	7.000 x 5.000
22.000	26.000	6.000 x 4.000	49.000	55.000	8.000 x 5.500
26.000	30.000	7.000 x 5.000			
30.000	34.000	8.000 x 5.500			
34.000	38.000	9.000 x 6.000			
38.000	42.000	10.000 x 7.000			
42.000	46.000	11.000 x 7.500			
46.000	50.000	12.000 x 8.000			
50.000	54.000	13.000 x 9.000			

# Engineering Data — Large Flanged Sleeve

**Table 24 — Flange Details (mm)**

Size	A	B	C	E	DD	F	G	H	J-Bolts No. Dia x Length (Per Flange) (in)	K-Bolts No. Dia x Length (in)	T
1080/2080G	590,6	527,05	441,33	7,9	6,4	571,5	527,05	31,8	16-.875 x 3.25	16- 1.125 x 4.125	441,27
1090/2090G	660,4	590,55	495,30	7,9	6,4	641,4	590,55	38,1	18- 1.000 x 3.50	18- 1.250 x 4.75	495,25
1100/2100G	711,2	641,35	546,10	9,7	7,9	698,5	641,35	44,4	18- 1.000 x 3.50	18- 1.250 x 5.25	546,05
1110/2110G	774,7	698,50	596,90	9,7	7,9	749,3	698,50	50,8	18- 1.000 x 3.50	18- 1.500 x 6.00	596,85
1120/2120G	838,2	762,00	654,05	9,7	7,9	825,5	762,00	53,8	18- 1.125 x 3.50	18- 1.500 x 6.25	654,00
1130/2130G	911,4	822,33	708,03	9,7	7,9	886,0	822,33	53,8	18- 1.250 x 4.50	18- 1.500 x 6.25	707,97
1140/2140G	965,2	876,30	758,83	9,7	7,9	939,8	876,30	53,8	18- 1.250 x 4.50	18- 1.750 x 6.50	758,77
1150/2150G	1 028,7	933,45	815,98	9,7	7,9	1 003,3	933,45	53,8	20- 1.250 x 4.50	20- 1.750 x 6.50	815,92
1160/2160G	1 111,2	1 009,65	863,60	12,7	9,7	1 085,9	1 009,65	57,2	20- 1.250 x 4.50	20- 2.000 x 7.00	863,50
1180/2180G	1 219,2	1 117,60	984,25	12,7	9,7	1 193,8	1 117,60	57,2	22- 1.250 x 4.50	22- 2.000 x 7.00	984,15
1200/2200G	1 358,9	1 231,90	1 085,85	12,7	9,7	1 308,1	1 231,90	63,5	22- 1.500 x 5.00	22- 2.250 x 7.75	1 085,75
1220/2220G	1 511,3	1 384,30	1 212,85	15,7	12,7	1 473,2	1 384,30	63,5	24- 1.500 x 5.00	24- 2.250 x 7.75	1 212,75
1240/2240G	1 632,0	1 479,55	1 289,05	15,7	12,7	1 581,2	1 479,55	76,2	22- 1.500 x 5.00	22- 2.750 x 9.75	1 288,95
1260/2260G	1 746,2	1 593,85	1 390,65	15,7	12,7	1 695,5	1 593,85	76,2	24- 1.500 x 5.00	24- 2.750 x 9.75	1 390,55
1280/2280G	1 866,9	1 701,80	1 492,25	15,7	12,7	1 803,4	1 701,80	82,6	22- 1.500 x 5.00	22- 3.000 x 10.50	1 492,15
1300/2300G	1 974,8	1 809,75	1 593,85	15,7	12,7	1 911,4	1 809,75	82,6	24- 1.500 x 5.00	24- 3.000 x 10.50	1 593,75

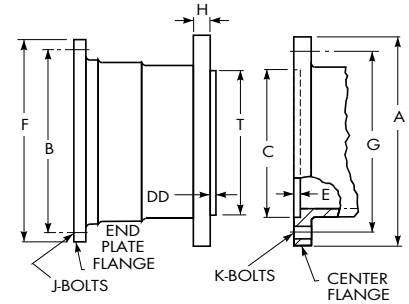

**Table 25 — Sleeve Jack Screw Holes**

Size	B.C. (mm)	Tap Size (in)
1080/2080G	527,0	.875-9 UNC
1090/2090G	590,6	1.000-8 UNC
1100/2100G	641,4	1.000-8 UNC
1110/2110G	698,5	1.000-8 UNC
1120/2120G	762,0	1.125-7 UNC
1130/2130G	822,3	1.250-7 UNC
1140/2140G	876,3	1.250-7 UNC
1150/2150G	933,4	1.250-7 UNC
1160/2160G	1 009,6	1.250-7 UNC
1180/2180G	1 117,6	1.250-7 UNC
1200/2200G	1 231,9	1.500-6 UNC
1220/2220G	1 384,3	1.500-6 UNC
1240/2240G	1 479,6	1.500-6 UNC
1260/2260G	1 593,8	1.500-6 UNC
1280/2280G	1 701,8	1.500-6 UNC
1300/2300G	1 809,8	1.500-6 UNC

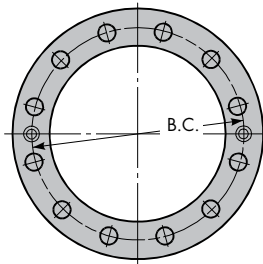

**Table 26 — Flex Hub Puller Bolt Holes for Standard Shank Diameter Hubs**

Size ①	B.C. (mm)	Tap Size – UNC (in)
1080/2080G	317,5	1.000-8 x 1.18
1090/2090G	355,6	1.250-7 x 1.50
1100/2100G	393,7	1.500-6 x 1.75
1110/2110G	444,5	1.500-6 x 1.75
1120/2120G	495,3	1.500-6 x 1.75
1130/2130G	533,4	1.500-6 x 1.75
1140/2140G	584,2	1.500-6 x 1.75
1150/2150G	635,0	1.500-6 x 1.75
1160/2160G	685,8	1.500-6 x 1.75
1180/2180G	774,7	1.500-6 x 1.75
1200/2200G	863,6	2.000-4.5 x 2.38
1220/2220G	952,5	2.000-4.5 x 2.38
1240/2240G	1 041,4	2.000-4.5 x 2.38
1260/2260G	1 143,0	2.000-4.5 x 2.38
1280/2280G	1 244,6	2.000-4.5 x 2.38
1300/2300G	1 346,2	2.000-4.5 x 2.38

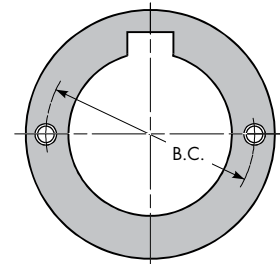

① Refer to **Table 34** for flex hub puller data on reduced shank diameter hubs, Sizes 1160/2160 thru 1300/2300.

**Table 27 — Torsional Stiffness – Nm/Radian (10<sup>6</sup>)**

Size	Half Couplings				Complete Coupling			
	Flex Half	Right Half			Type G20	Type G52		
		Large Shank	Medium Shank	Small Shank		Large Shank	Medium Shank	Small Shank
1080/2080G	510,7	1 412,4	–	–	255,4	375,1	–	–
1090/2090G	696,0	2 056,4	–	–	348,0	519,8	–	–
1100/2100G	881,3	2 248,5	–	–	440,7	632,7	–	–
1110/2110G	1 068,9	3 028,1	–	–	534,4	790,9	–	–
1120/2120G	1 423,7	4 304,9	–	–	711,8	1 070,0	–	–
1130/2130G	1 794,3	5 785,1	–	–	897,1	1 367,2	–	–
1140/2140G	2 119,7	6 835,9	–	–	1 059,9	1 615,8	–	–
1150/2150G	2 508,2	8 802,0	–	–	1 254,2	1 954,7	–	–
1160/2160G	3 457,5	12 078,7	7 412,2	2 994,2	1 728,8	2 689,2	2 361,5	1 604,5
1180/2180G	5 265,4	18 315,8	10 937,5	4 700,4	2 632,7	4 101,6	3 559,2	2 485,8
1200/2200G	5 988,5	23 004,9	13 705,8	6 022,4	2 994,2	4 745,6	4 158,1	3 005,5
1220/2220G	10 824,5	34 857,6	17 875,1	8 146,6	5 412,2	8 259,6	6 745,5	4 643,9
1240/2240G	10 508,1	40 789,6	23 106,6	10 496,8	5 254,1	8 350,0	7 220,1	5 254,1
1260/2260G	13 197,3	51 862,6	28 993,4	13 581,5	6 598,6	10 519,4	9 073,1	6 700,3
1280/2280G	17 377,9	67 737,8	37 422,5	18 055,9	8 689,0	13 830,0	11 864,0	8 858,5
1300/2300G	22 146,1	86 155,3	47 139,6	23 264,7	11 073,1	17 615,2	15 072,9	11 344,2

**Table 28 — WR<sup>2</sup> Values (Kgm<sup>2</sup>)**

WR<sup>2</sup> values are based on hubs with no bore.

Size	Type G20 Double Engagement	Type G52 Single Engagement
1080/2080G	22,2	21,2
1090/2090G	39,9	38,0
1100/2100G	61,7	55,5
1110/2110G	93,3	86,5
1120/2120G	138	130
1130/2130G	198	189
1140/2140G	269	256
1150/2150G	365	351
1160/2160G	526	514
1180/2180G	850	829
1200/2200G	1 455	1 425
1220/2220G	2 475	2 413
1240/2240G	3 565	3 492
1260/2260G	4 887	4 883
1280/2280G	6 636	6 694
1300/2300G	8 742	8 807

## Engineering Data — Large Flanged Sleeve

### Data for couplings with reduced shank diameter hubs:

Depending upon bore, a reduced shank diameter hub (Dimension “N” or “K”) is available for each coupling, sizes 1160/2160 thru 1300/2300. This provides reduced weight and WR<sup>2</sup>.

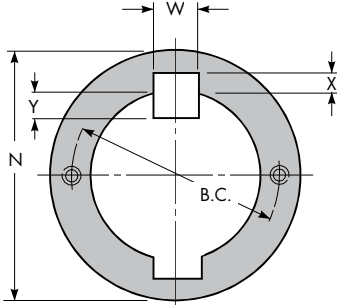

**Table 29 — Bore Ranges for Reduced Shank Diameter Hubs (mm)**

Size ①	Flex Hub			Weight (kg)		Coupling WR <sup>2</sup> (KgM <sup>2</sup> )	Rigid Hub		K ②	Weight (kg) ③			Coupling WR <sup>2</sup> (KgM <sup>2</sup> )
	Max Bore- (mm) ④	Min Bore (mm)	N ②	Sleeves, End Rings And Fasteners	Flex Hub with No Bore (Each)		Max Bore- (mm) ④	Min Bore (mm)		Sleeves, End Rings And Fasteners	Flex Hub with No Bore (Each)	Rigid Hub with No Bore (Each)	
1160/2160G	463	330	647,7	1388	1388	470	562	375	787,4	748	1388	1901	418
	376	254	527,0	1388	1193	437	426	254	596,9	***	1193	1383	338
1180/2180G	535	381	749,3	1642	1878	767	626	419	876,3	885	1878	2413	671
	435	286	609,6	1642	1601	702	481	286	673,1	***	1601	1787	543
1200/2200G	608	432	850,9	2200	2749	1315	689	470	965,2	1184	2749	3434	1152
	494	318	692,2	2200	2291	1169	535	318	749,3	***	2291	2549	922
1220/2220G	680	489	952,5	3257	3706	2275	753	515	1054,1	1724	3706	4468	1910
	558	349	781,0	3257	3093	2033	590	350	825,5	***	3093	3361	1545
1240/2240G	753	540	1054,1	3633	4826	3252	816	565	1143,0	1978	4826	5693	2808
	617	381	863,6	3633	3978	2848	644	381	901,7	***	3978	4264	2234
1260/2260G	826	591	1155,7	3978	6142	4454	880	610	1231,9	2164	6142	7013	3890
	676	413	946,2	3978	5008	4588	699	413	977,9	***	5008	5298	3038
1280/2280G	898	650	1257,3	4627	7412	6081	943	660	1320,8	2517	7412	8319	5288
	739	445	1035,0	4627	6055	5147	753	445	1054,1	***	6055	6382	4142
1300/2300G	971	700	1358,9	5185	8845	8035	1007	705	1409,7	2817	8845	9671	6961
	798	476	1117,6	5185	7199	6742	807	476	1130,3	***	7199	7466	5435

① See page 11 for General Information.

② Hubs with the least possible “K” or “N” dimension for the required bore are normally furnished.

③ Total weight of coupling varies with “K” or “N” dimension of rigid and flex hub selection. Add weight of selected hubs to “Sleeve, End Ring and Fasteners” weight.

④ Maximum bores are reduced for hubs furnished with an interference fit and a setscrew over the keyway. Refer to **Table 13 and Table 14, page 43**. Bore capacities can be increased beyond values shown if the coupling torque rating is reduced. Refer to the Factory. Recommended key sizes for the listed maximum bores are shown in **Table 34, page 51**, and **Table 23, page 47**.

**Table 30 — Flex Hub Puller Bolt Holes for Reduced Shank Diameter Hubs (mm)**

Size ①	N	B.C.	Tap Size (in)	Size ①	N	B.C.	Tap Size (in)
1160/2160G	647,7	571,5	1.500-6 UNC	1240/2240G	1 054,1	927,1	2-4.5 UNC
	527,0	450,8			863,6	749,3	
1180/2180G	749,3	660,4	1.500-6 UNC	1260/2260G	1 155,7	1 028,7	2-4.5 UNC
	609,6	520,7			946,1	819,2	
1200/2200G	850,9	749,3	2-4.5 UNC	1280/2280G	1 257,3	1 130,3	2-4.5 UNC
	692,2	590,6			1 035,0	908,0	
1220/2220G	952,5	838,2	2-4.5 UNC	1300/2300G	1 358,9	1 231,9	2-4.5 UNC
	781,1	666,8			1 117,6	990,6	

# Engineering Data — Large Flanged Sleeve

## Standard Filleted Keyways & Chamfered Keys

It is general practice in industry to supply coupling hubs with minimum fillet radii in the keyway corners to permit the use of standard commercial keys without chamfered edges. Rexnord will cut filleted keyways when specified in accordance with the established industry standards as shown in **Table 31** at no extra charge.

**Table 31 — Standard Filleted Keyways & Chamfered Keys (mm)**

Normal Bore		Key		Hub Keyway			
Over	Thru	Size (Nominal)	45° Chamfer Suggested	Width	Depth ①	Fillet Radii	
95	110	28 x 16	0,70	28	+/- 0,026	6,4 / 6,6	0,60
110	130	32 x 18	0,70			32	+/- 0,031
130	150	36 x 20	1,10	36	↓	8,4 / 8,7	
150	170	40 x 22	1,10	40		+/- 0,037	9,4 / 9,7
170	200	45 x 25	1,10	45	↓		10,4 / 10,7
200	230	50 x 28	1,10	50		+/- 0,037	11,4 / 11,7
230	260	56 x 32	1,80	56	↓		12,4 / 12,7
260	290	63 x 32	1,80	63		+/- 0,044	12,4 / 12,7
290	330	70 x 36	1,80	70	↓		14,4 / 14,7
330	380	80 x 40	2,70	80		+/- 0,044	15,4 / 15,7
380	440	90 x 45	2,70	90	↓		17,4 / 17,7
440	500	100 x 50	2,70	100		+/- 0,044	19,5 / 19,8

① Shallow keyway depths must be equal or exceed 2/3 of the full keyway depth of the square keys shown above.

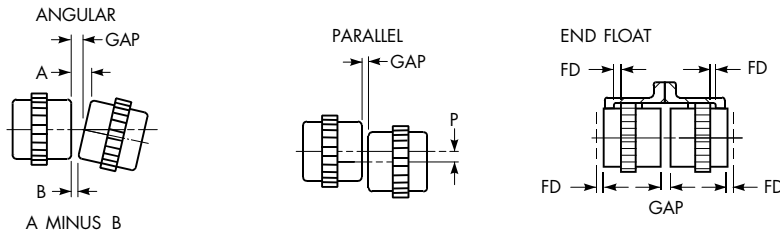

**Table 32 — Misalignment & End Float – Double Engagement Couplings**

Size	Angular Misalignment Limits						Parallel Misalignment Limits						End Float		
	Installation		Operating ②		Static ②		Installation		Operating ②		Static ②		Std FD (Min)	Normal GAP +/-10%	Physical Limit (Min) (2) FD +GAP
	A Minus B (mm)	Degrees per Mesh	A Minus B (mm)	Degrees per Mesh	A Minus B (mm)	Degrees per Mesh	P (mm)	Degrees per Mesh	P (mm)	Degrees per Mesh	P (mm)	Degrees per Mesh			
1080/2080	0,81	1/16°	4,83	3/8°	9,65	3/4°	0,41	1/16°	2,46	3/8°	4,90	3/4°	4,32	10	18
1090/2090	0,91	1/16°	5,49	3/8°	10,97	3/4°	0,43	1/16°	2,64	3/8°	5,23	3/4°	6,30	13	25
1100/2100	1,02	1/16°	6,15	3/8°	12,29	3/4°	0,48	1/16°	2,97	3/8°	5,94	3/4°	6,30	13	25
1110/2110	1,14	1/16°	6,81	3/8°	13,64	3/4°	0,56	1/16°	3,30	3/8°	6,58	3/4°	6,30	13	25
1120/2120	1,24	1/16°	7,49	3/8°	14,99	3/4°	0,58	1/16°	3,51	3/8°	7,04	3/4°	6,30	13	25
1130/2130	1,32	1/16°	7,98	3/8°	15,95	3/4°	0,61	1/16°	3,61	3/8°	7,24	3/4°	8,76	19	37
1140/2140	1,45	1/16°	8,64	3/8°	17,30	3/4°	0,64	1/16°	3,81	3/8°	7,59	3/4°	8,76	19	37
1150/2150	1,55	1/16°	9,32	3/8°	18,62	3/4°	0,69	1/16°	4,17	3/8°	8,33	3/4°	8,76	19	37
1160/2160	1,60	1/16°	9,65	3/8°	19,28	3/4°	0,71	1/16°	4,22	3/8°	8,41	3/4°	11,68	25	49
1180/2180	1,83	1/16°	10,97	3/8°	21,95	3/4°	0,74	1/16°	4,37	3/8°	8,74	3/4°	11,68	25	49
1200/2200	2,03	1/16°	12,14	3/8°	24,28	3/4°	0,89	1/16°	5,28	3/8°	10,57	3/4°	11,68	25	49
1220/2220	2,21	1/16°	13,31	3/8°	26,59	3/4°	0,99	1/16°	5,87	3/8°	11,73	3/4°	11,68	25	49
1240/2240	2,46	1/16°	14,78	3/8°	29,59	3/4°	1,07	1/16°	6,40	3/8°	12,80	3/4°	11,68	25	49
1260/2260	2,69	1/16°	16,13	3/8°	32,46	3/4°	1,17	1/16°	6,93	3/8°	13,89	3/4°	11,68	25	49
1280/2280	2,92	1/16°	17,45	3/8°	34,90	3/4°	1,19	1/16°	7,14	3/8°	14,30	3/4°	11,68	25	49
1300/2300	3,12	1/16°	18,80	3/8°	37,57	3/4°	1,22	1/16°	7,37	3/8°	14,71	3/4°	11,68	25	49

② These maximum operating alignment limits are each based on 3/8° per flex half coupling. Combined values of parallel and angular misalignment should not exceed 3/8°. Type GL slide couplings are limited to 1/4° per flex half. Application requirements in excess of these values should be referred to the Factory for review.

## Engineering Data — Large Flanged Sleeve

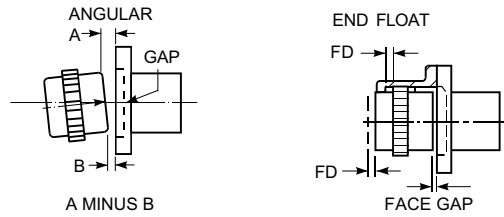

Table 33 — Misalignment & End Float – Single Engagement Couplings (mm)

Size	Angular Misalignment Limits ①						End Float			
	Installation		Operating		Static		Std FD (Min) (mm)	Normal Shaft GAP (mm)	Normal Face GAP (X) (mm)	Physical Limit (Min) FD + GAP (mm)
	A Minus B (mm)	Degrees per Mesh	A Minus B (mm)	Degrees per Mesh	A Minus B (mm)	Degrees per Mesh				
1080/2080	0,81	1/8 °	2,41	3/8°	4,83	3/4°	4,57	13	5	17
1090/2090	0,91	1/8 °	2,74	3/8°	5,49	3/4°	6,55	14	6	21
1100/2100	1,02	1/8 °	3,07	3/8°	6,15	3/4°	6,48	16	6	22
1110/2110	1,14	1/8 °	3,40	3/8°	6,81	3/4°	6,48	16	6	22
1120/2120	1,24	1/8 °	3,73	3/8°	7,49	3/4°	6,48	16	6	22
1130/2130	1,32	1/8 °	3,99	3/8°	7,98	3/4°	8,64	19	9	28
1140/2140	1,45	1/8 °	4,32	3/8°	8,64	3/4°	8,64	19	9	28
1150/2150	1,55	1/8 °	4,65	3/8°	9,32	3/4°	8,64	19	9	28
1160/2160	1,60	1/8 °	4,83	3/8°	9,65	3/4°	11,43	25	13	37
1180/2180	1,83	1/8 °	5,49	3/8°	10,97	3/4°	11,43	25	13	37
1200/2200	2,03	1/8 °	6,07	3/8°	12,14	3/4°	11,43	25	13	37
1220/2220	2,21	1/8 °	6,65	3/8°	13,31	3/4°	11,43	29	13	40
1240/2240	2,46	1/8 °	7,39	3/8°	14,78	3/4°	11,43	29	13	40
1260/2260	2,69	1/8 °	8,05	3/8°	16,13	3/4°	11,43	29	13	40
1280/2280	2,92	1/8 °	8,74	3/8°	17,45	3/4°	11,30	29	13	40
1300/2300	3,12	1/8 °	9,40	3/8°	18,80	3/4°	11,30	29	13	40

① Do not use single engagement couplings to compensate for parallel offset misalignment.

## Engineering Data — All Gear Couplings

Table 34 — Recommended Commercial Keys for Bores with One Key (in/mm)

Inches (Per ANSI B17.1 Standard)											
Shaft Diameter		Key	Shaft Diameter		Key	Shaft Diameter		Key	Shaft Diameter		Key
Over	Through		Over	Through		Over	Through		Over	Through	
0.438	0.562	0.125 x 0.125	1.750	2.250	0.500 x 0.500	4.500	5.500	1.250 x 1.250	11.000	13.000	3.000 x 2.000
0.562	0.875	0.188 x 0.188	2.250	2.750	0.625 x 0.625	5.500	6.500	1.500 x 1.500	13.000	15.000	3.500 x 2.500
0.875	1.250	0.250 x 0.250	2.750	3.250	0.750 x 0.750	6.500	7.500	1.750 x 1.500	15.000	18.000	4.000 x 3.000
1.250	1.375	0.312 x 0.312	3.250	3.750	0.875 x 0.875	7.500	9.000	2.000 x 1.500	18.000	22.000	5.000 x 3.500
1.375	1.750	0.375 x 0.375	3.750	4.500	1.000 x 1.000	9.000	11.000	2.500 x 1.750	–	–	–

Millimeters (Per ISO R773 Standard)											
Shaft Diameter		Key	Shaft Diameter		Key	Shaft Diameter		Key	Shaft Diameter		Key
Over	Through		Over	Through		Over	Through		Over	Through	
6	8	2 x 2	38	44	12 x 8	95	110	28 x 16	260	290	63 x 32
8	10	3 x 3	44	50	14 x 9	110	130	32 x 18	290	330	70 x 36
10	12	4 x 4	50	58	16 x 10	130	150	36 x 20	330	380	80 x 40
12	17	5 x 5	58	65	18 x 11	150	170	40 x 22	380	440	90 x 45
17	22	6 x 6	65	75	20 x 12	170	200	45 x 25	440	500	100 x 50
22	30	8 x 7	75	85	22 x 14	200	230	50 x 28	–	–	–
30	38	10 x 8	85	95	25 x 14	230	260	56 x 32	–	–	–

# Engineering Data — All Gear Couplings

Table 35 — Recommended Hub Inch Bores for Clearance & Interference Fit (in)

Shaft Dia	Clearance Fit ②		Interference Fit ①		Shaft Dia	Clearance Fit ②		Interference Fit ①		Shaft Dia	Interference Fit ①		Shaft Dia	Interference Fit ①	
	Hub Bore	Clearance	Hub Bore	Interference		Hub Bore	Clearance	Hub Bore	Interference		Hub Bore	Interference		Hub Bore	Interference
+ .0000	+ .0010	.0000	+ .0005	.0000	+ .0000	+ .0015	.0000	+ .0015	.0010	+ .0000	+ .0015	.0015	+ .000	+ .003	.0110
-.0005	-.0000	.0015	-.0000	.0010	-.0010	-.0000	.0025	-.0000	.0035	-.0010	-.0000	.0040	-.002	-.000	.0160
0.5000	0.5000		0.4990		4.0625	4.0625		4.0590		6.7500	6.7460		26.500	26.4840	
0.5625	0.5625		0.5615		4.1250	4.1250		4.1215		7.0000	6.9960		27.000	26.9840	
0.6250	0.6250		0.6240		4.1875	4.1875		4.1840		+ .0000	+ .0020	.0020	27.500	27.4840	
0.6875	0.6875		0.6865		4.2500	4.2500		4.2465		-.0010	-.0000	.0050	28.000	27.9840	
0.7500	0.7500		0.7490		4.3125	4.3125		4.3090		7.250	7.2450		28.500	28.4830	.0120
0.8125	0.8125		0.8115		4.3750	4.3750		4.3715		7.500	7.4950		29.000	28.9830	.0170
0.8750	0.8750		0.8740		4.4375	4.4375		4.4340		7.750	7.7450		29.500	29.4830	
0.9375	0.9375		0.9365		4.5000	4.5000		4.4965		8.000	7.9950		30.000	29.9830	
1.0000	1.0000		0.9990		4.5625	4.5625		4.5590		8.250	8.2445	.0025	+ .000	+ .004	.0110
1.0625	1.0625		1.0615		4.6250	4.6250		4.6215		8.500	8.4945	.0055	-.003	-.000	.0180
1.1250	1.1250		1.1240		4.6875	4.6875		4.6840		8.750	8.7445		30.500	30.4820	
1.1875	1.1875		1.1865		4.7500	4.7500		4.7465		9.000	8.9945		31.000	30.9820	
1.2500	1.2500		1.2490		4.8125	4.8125		4.8090		9.250	9.2440	.0030	31.500	31.4810	.0120
1.3125	1.3125		1.3115		4.8750	4.8750		4.8715		9.500	9.4940	.0060	32.000	31.9810	.0190
1.3750	1.3750		1.3740		4.9375	4.9375		4.9340		9.750	9.7440		32.500	32.4810	
1.4375	1.4375		1.4365		5.0000	5.0000		4.9965		10.000	9.9940		33.000	32.9810	
1.5000	1.5000		1.4990		5.0625	5.0625		5.0585	.0015	10.250	10.2435	.0035	33.500	33.4800	.0130
+ .0000	+ .0010	.0000	+ .0005	.0000	5.1250	5.1250		5.1210	.0040	10.500	10.4935	.0065	34.000	33.9800	.0200
-.0010	-.0000	.0020	-.0000	.0015	5.1875	5.1875		5.1835		10.750	10.7435		34.500	34.4800	
1.5625	1.5625		1.5610		5.2500	5.2500		5.2460		11.000	10.9935		35.000	34.9790	
1.6250	1.6250		1.6235		5.3125	5.3125		5.3085		11.250	11.2430	.0040	+ .000	+ .004	.0140
1.6875	1.6875		1.6860		5.3750	5.3750		5.3710		11.500	11.4930	.0070	-.003	-.000	.0210
1.7500	1.7500		1.7485		5.4375	5.4375		5.4335		11.750	11.7430		35.500	35.4790	
1.8125	1.8125		1.8110		5.5000	5.5000		5.4960		12.000	11.9930		36.000	36.9790	
1.8750	1.8750		1.8735		5.5625	5.5625		5.5585		12.500	12.4925	.0045	36.500	36.4790	
1.9375	1.9375		1.9360		5.6250	5.6250		5.6210		13.000	12.9925	.0075	37.000	36.9790	
2.0000	2.0000		1.9985		5.6875	5.6875		5.6835		13.500	13.4920	.0050	+ .000	+ .004	.0150
+ .0000	+ .0015	.0000	+ .0005	.0000	5.7500	5.7500		5.7460		14.000	13.9920	.0080	-.003	-.000	.0220
-.0010	-.0000	.0025	-.0000	.0015	5.8125	5.8125		5.8085		14.500	14.4915	.0055	37.500	37.4780	
2.0625	2.0625		2.0610		5.8750	5.8750		5.8710		15.000	14.9915	.0085	38.000	37.9780	
2.1250	2.1250		2.1235		5.9375	5.9375		5.9335		+ .000	+ .0025	.0055	38.500	38.4780	
2.1875	2.1875		2.1860		6.0000	6.0000		5.9960		-.001	-.0000	.0090	39.000	38.9780	
+ .0000	+ .0015	.0000	+ .0010	.0000	6.2500	6.2500		6.2460		15.500	15.4910		39.500	39.4970	.0160
-.0010	-.0000	.0025	-.0000	.0020	6.5000	6.5000		6.4960		16.000	15.9910		40.000	39.9770	.0230
2.2500	2.2500		2.2480							16.500	16.4905	.0060	+ .000	+ .005	.0150
2.3125	2.3125		2.3105							17.000	16.9905	.0095	-.004	-.000	.0240
2.3750	2.3750		2.3730							17.500	17.4895	.0070	40.500	40.4760	
2.4375	2.4375		2.4355							18.000	17.9895	.0105	41.000	40.9760	
2.5000	2.5000		2.4980							18.500	18.4890	.0075	41.500	41.4760	
2.5625	2.5625		2.5605							19.000	18.9890	.0110	42.000	41.9760	
2.6250	2.6250		2.6230							19.500	19.4880	.0085	42.500	42.4750	.0160
2.6875	2.6875		2.6855							20.000	19.9880	.0120	43.000	42.9750	.0250
2.7500	2.7500		2.7480							+ .000	+ .003	.0080	43.500	43.4750	
2.8125	2.8125		2.8105							-.002	-.000	.0130	44.000	43.9750	
2.8750	2.8750		2.8730							20.500	20.4870		44.500	44.4740	.0170
2.9375	2.9375		2.9355							21.000	20.9870		45.000	44.9740	.0260
3.0000	3.0000		2.9980							21.500	21.4870		45.500	45.4740	
+ .0000	+ .0015	.0000	+ .0010	.0005						22.000	21.9870		46.000	45.9740	
-.0010	-.0000	.0025	-.0000	.0025						22.500	22.4860	.0090	46.500	46.4730	.0180
3.0625	3.0625		3.0600							23.000	22.9860	.0140	47.000	46.9730	.0270
3.1250	3.1250		3.1225							23.500	23.4860		47.500	47.4730	
3.1875	3.1875		3.1850							24.000	23.9860		48.000	47.9730	
3.2500	3.2500		3.2475							+ .000	+ .003	.0100	48.500	48.4720	.0190
3.3125	3.3125		3.3100							-.002	-.000	.0150	49.000	48.9720	.0280
3.3750	3.3750		3.3725							24.500	24.4850		49.500	49.4720	
3.4375	3.4375		3.4350							25.000	24.9850		50.000	49.9720	
3.5000	3.5000		3.4975							25.500	25.4850		50.500	50.4710	.0200
3.5625	3.5625		3.5600							26.000	25.9850		51.000	50.9710	.0290
3.6250	3.6250		3.6225										51.500	51.4710	
3.6875	3.6875		3.6850										52.000	51.9710	
3.7500	3.7500		3.7475										52.500	52.4700	.0210
3.8125	3.8125		3.8100										53.000	52.9700	.0300
3.8750	3.8750		3.8725										53.500	53.4700	
3.9375	3.9375		3.9350										54.000	53.9700	
4.0000	4.0000		3.9975												

① Based on an average interference fit of 0.0005" per inch (0.5 mm per m) of shaft diameter. Tolerances and fits comply with, or are within AGMA 9002 standards.

② Rexnord gear couplings are supplied with an interference fit as a standard. Clearance fits can be provided on request.

# Engineering Data — All Gear Couplings

**Table 36 — Recommended Hub Bores for Clearance & Interference Fit on Keyed Shafting**

	Shaft Diameter	Clearance Fit		Transitional Fit		Interference Fit	
		Hub Bore	Fit <sup>①</sup>	Hub Bore	Fit <sup>①</sup>	Hub Bore	Fit <sup>①</sup>
>12	j6	F7	0,008	H7	-0,008	M6	-0,023
MM	0,008 / -0,003	0,016 / 0,034	0,037	0,000 / 0,018	0,021	-0,015 / -0,004	-0,001
12	12,008 / 11,997	12,016 / 12,034	↓	12,000 / 12,018	↓	11,985 / 11,996	↓
14	14,008 / 13,997	14,016 / 14,034	↓	14,000 / 14,018	↓	13,985 / 13,996	↓
16	16,008 / 15,997	16,016 / 16,034	↓	16,000 / 16,018	↓	15,985 / 15,996	↓
18	18,008 / 17,997	18,016 / 18,034	↓	18,000 / 18,018	↓	17,985 / 17,996	↓
>18	j6	F7	0,011	H7	-0,009	M6	-0,026
MM	0,009 / -0,004	0,020 / 0,041	0,045	0,000 / 0,021	0,025	-0,017 / -0,004	0,000
19	19,009 / 18,996	19,020 / 19,041	↓	19,000 / 19,021	↓	18,983 / 18,996	↓
20	20,009 / 19,996	20,020 / 20,041	↓	20,000 / 20,021	↓	19,983 / 19,996	↓
22	22,009 / 21,996	22,020 / 22,041	↓	22,000 / 22,021	↓	21,983 / 21,996	↓
24	24,009 / 23,996	24,020 / 24,041	↓	24,000 / 24,021	↓	23,983 / 23,996	↓
25	25,009 / 24,996	25,020 / 25,041	↓	25,000 / 25,021	↓	24,983 / 24,996	↓
28	28,009 / 27,996	28,020 / 28,041	↓	28,000 / 28,021	↓	27,983 / 27,996	↓
30	30,009 / 29,996	30,020 / 30,041	↓	30,000 / 30,021	↓	29,983 / 29,996	↓
>30	k6	F7	0,007	H7	-0,018	K6	-0,031
MM	0,018 / 0,002	0,025 / 0,050	0,048	0,000 / 0,025	0,023	-0,013 / 0,003	0,001
32	32,018 / 32,002	32,025 / 32,050	↓	32,000 / 32,025	↓	31,987 / 32,003	↓
35	35,018 / 35,002	35,025 / 35,050	↓	35,000 / 35,025	↓	34,987 / 35,003	↓
38	38,018 / 38,002	38,025 / 38,050	↓	38,000 / 38,025	↓	37,987 / 38,003	↓
40	40,018 / 40,002	40,025 / 40,050	↓	40,000 / 40,025	↓	39,987 / 40,003	↓
42	42,018 / 42,002	42,025 / 42,050	↓	42,000 / 42,025	↓	41,987 / 42,003	↓
45	45,018 / 45,002	45,025 / 45,050	↓	45,000 / 45,025	↓	44,987 / 45,003	↓
48	48,018 / 48,002	48,025 / 48,050	↓	48,000 / 48,025	↓	47,987 / 48,003	↓
50	50,018 / 50,002	50,025 / 50,050	↓	50,000 / 50,025	↓	49,987 / 50,003	↓
>50	m6	F7	0,000	H7	-0,030	K7	-0,051
MM	0,030 / 0,011	0,030 / 0,060	0,049	0,000 / 0,030	0,019	-0,021 / 0,009	-0,002
55	55,030 / 55,011	55,030 / 55,060	↓	55,000 / 55,030	↓	54,979 / 55,009	↓
56	56,030 / 56,011	56,030 / 56,060	↓	56,000 / 56,030	↓	55,979 / 56,009	↓
60	60,030 / 60,011	60,030 / 60,060	↓	60,000 / 60,030	↓	59,979 / 60,009	↓
63	63,030 / 63,011	63,030 / 63,060	↓	63,000 / 63,030	↓	62,979 / 63,009	↓
65	65,030 / 65,011	65,030 / 65,060	↓	65,000 / 65,030	↓	64,979 / 65,009	↓
70	70,030 / 70,011	70,030 / 70,060	↓	70,000 / 70,030	↓	69,979 / 70,009	↓
71	71,030 / 71,011	71,030 / 71,060	↓	71,000 / 71,030	↓	70,979 / 71,009	↓
75	75,030 / 75,011	75,030 / 75,060	↓	75,000 / 75,030	↓	74,979 / 75,009	↓
80	80,030 / 80,011	80,030 / 80,060	↓	80,000 / 80,030	↓	79,979 / 80,009	↓
>80	m6	F7	0,001	H7	-0,035	M7	-0,070
MM	0,035 / 0,013	0,036 / 0,071	0,058	0,000 / 0,035	0,022	-0,035 / 0,000	-0,013
85	85,035 / 85,013	85,036 / 85,071	↓	85,000 / 85,035	↓	84,965 / 85,000	↓
90	90,035 / 90,013	90,036 / 90,071	↓	90,000 / 90,035	↓	89,965 / 90,000	↓
95	95,035 / 95,013	95,036 / 95,071	↓	95,000 / 95,035	↓	94,965 / 95,000	↓
100	100,035 / 100,013	100,036 / 100,071	↓	100,000 / 100,035	↓	99,965 / 100,000	↓
>100	m6	F7	0,003	H7	-0,040	P7	-0,108
MM	0,040 / 0,015	0,043 / 0,083	0,068	0,000 / 0,040	0,025	-0,068 / -0,028	-0,043
110	110,035 / 110,013	110,036 / 110,071	↓	110,000 / 110,035	↓	109,941 / 109,976	↓
120	120,035 / 120,013	120,036 / 120,071	↓	120,000 / 120,035	↓	119,941 / 119,976	↓
>120	m6	F7	0,003	H7	-0,040	P7	-0,108
MM	0,040 / 0,015	0,043 / 0,083	0,068	0,000 / 0,040	0,025	-0,068 / -0,028	-0,043
125	125,040 / 125,015	125,043 / 125,083	↓	125,000 / 125,040	↓	124,932 / 124,972	↓
130	130,040 / 130,015	130,043 / 130,083	↓	130,000 / 130,040	↓	129,932 / 129,972	↓
140	140,040 / 140,015	140,043 / 140,083	↓	140,000 / 140,040	↓	139,932 / 139,972	↓
150	150,040 / 150,015	150,043 / 150,083	↓	150,000 / 150,040	↓	149,932 / 149,972	↓
160	160,040 / 160,015	160,043 / 160,083	↓	160,000 / 160,040	↓	159,932 / 159,972	↓
170	170,040 / 170,015	170,043 / 170,083	↓	170,000 / 170,040	↓	169,932 / 169,972	↓
180	180,040 / 180,015	180,043 / 180,083	↓	180,000 / 180,040	↓	179,932 / 179,972	↓

	Shaft Diameter	Clearance Fit		Transitional Fit		Interference Fit	
		Hub Bore	Fit <sup>①</sup>	Hub Bore	Fit <sup>①</sup>	Hub Bore	Fit <sup>①</sup>
>180	m6	F7	0,004	H7	-0,046	P7	-0,125
MM	0,046 / 0,017	0,050 / 0,096	0,079	0,000 / 0,046	0,029	-0,079 / -0,033	-0,050
190	190,046 / 190,017	190,050 / 190,096	↓	190,000 / 190,046	↓	189,921 / 189,967	↓
200	200,046 / 190,017	200,050 / 200,096	↓	200,000 / 200,046	↓	199,921 / 199,967	↓
>200	m6	F7	0,000	H7	-0,046	R7	-0,155
MM	0,046 / 0,017	0,050 / 0,096	0,079	0,000 / 0,046	0,029	-0,109 / -0,063	-0,080
210	210,046 / 210,017	210,050 / 210,096	↓	210,000 / 210,046	↓	209,891 / 209,937	↓
220	220,046 / 220,017	220,050 / 220,096	↓	220,000 / 220,046	↓	219,891 / 219,937	↓
225	225,046 / 225,017	225,050 / 225,096	↓	225,000 / 225,046	↓	224,891 / 224,937	↓
>225	m6	F7	0,000	H7	-0,046	R7	-0,159
MM	0,046 / 0,017	0,050 / 0,096	0,079	0,000 / 0,046	0,029	-0,113 / -0,067	-0,084
230	230,046 / 230,017	230,050 / 230,096	↓	230,000 / 230,046	↓	229,887 / 229,933	↓
240	240,046 / 240,017	240,050 / 240,096	↓	240,000 / 240,046	↓	239,887 / 239,933	↓
250	250,046 / 250,017	250,050 / 250,096	↓	250,000 / 250,046	↓	249,887 / 249,933	↓
>250	m6	F7	0,004	H7	-0,052	R7	-0,178
MM	0,052 / 0,020	0,056 / 0,108	0,088	0,000 / 0,052	0,032	-0,126 / -0,074	-0,094
260	260,052 / 260,020	260,056 / 260,108	↓	260,000 / 260,052	↓	259,874 / 259,926	↓
270	270,052 / 270,020	270,056 / 270,108	↓	270,000 / 270,052	↓	269,874 / 269,926	↓
280	280,052 / 280,020	280,056 / 280,108	↓	280,000 / 280,052	↓	279,874 / 279,926	↓
>280	m6	F7	0,000	H7	-0,052	R7	-0,182
MM	0,052 / 0,020	0,056 / 0,108	0,088	0,000 / 0,052	0,032	-0,130 / -0,078	-0,098
290	290,052 / 290,020	290,056 / 290,108	↓	290,000 / 290,052	↓	289,870 / 289,922	↓
300	300,052 / 300,020	300,056 / 300,108	↓	300,000 / 300,052	↓	299,870 / 299,922	↓
310	310,052 / 310,020	310,056 / 310,108	↓	310,000 / 310,052	↓	309,870 / 309,922	↓
315	315,052 / 315,020	315,056 / 315,108	↓	315,000 / 315,052	↓	314,870 / 314,922	↓
>315	m6	F7	0,005	H7	-0,057	R7	-0,201
MM	0,057 / 0,021	0,062 / 0,119	0,098	0,000 / 0,057	0,036	-0,144 / -0,087	-0,108
320	320,057 / 320,021	320,062 / 320,119	↓	320,000 / 320,057	↓	319,856 / 319,913	↓
330	330,057 / 330,021	330,062 / 330,119	↓	330,000 / 330,057	↓	329,856 / 329,913	↓
340	340,057 / 340,021	340,062 / 340,119	↓	340,000 / 340,057	↓	339,856 / 339,913	↓
350	350,057 / 350,021	350,062 / 350,119	↓	350,000 / 350,057	↓	349,856 / 349,913	↓
355	355,057 / 355,021	355,062 / 355,119	↓	355,000 / 355,057	↓	354,856 / 354,913	↓
>355	m6	F7	0,000	H7	-0,057	R8	-0,260
MM	0,057 / 0,021	0,062 / 0,119	0,098	0,000 / 0,057	0,036	-0,203 / -0,114	-0,135
360	360,057 / 360,021	360,062 / 360,119	↓	360,000 / 360,057	↓	359,797 / 359,886	↓
370	370,057 / 370,021	370,062 / 370,119	↓	370,000 / 370,057	↓	369,797 / 369,886	↓
380	380,057 / 380,021	380,062 / 380,119	↓	380,000 / 380,057	↓	379,797 / 379,886	↓
390	390,057 / 390,021	390,062 / 390,119	↓	390,000 / 390,057	↓	389,797 / 389,886	↓
400	400,057 / 400,021	400,062 / 400,119	↓	400,000 / 400,057	↓	399,797 / 399,886	↓
>400	m6	F7	0,005	H7	-0,063	R8	-0,296
MM	0,063 / 0,023	0,068 / 0,131	0,108	0,000 / 0,063	0,040	-0,233 / -0,126	-0,149
410	410,063 / 410,023	410,068 / 410,131	↓	410,000 / 410,063	↓	409,767 / 409,874	↓
420	420,063 / 420,023	420,068 / 420,131	↓	420,000 / 420,063	↓	419,767 / 419,874	↓
430	430,063 / 430,023	430,068 / 430,131	↓	430,000 / 430,063	↓	429,767 / 429,874	↓
440	440,063 / 440,023	440,068 / 440,131	↓	440,000 / 440,063	↓	439,767 / 439,874	↓
450	450,063 / 450,023	450,068 / 450,131	↓	450,000 / 450,063	↓	449,767 / 449,874	↓
>450	m6	F7	0,000	H7	-0,063	R8	-0,292
MM	0,063 / 0,023	0,068 / 0,131	0,108	0,000 / 0,063	0,040	-0,229 / -0,132	-0,155
460	460,063 / 460,023	460,068 / 460,131	↓	460,000 / 460,063	↓	459,771 / 459,868	↓
470	470,0						

# Lifalign Gear Coupling Nomenclature

## Type GC (pages 54-54 & pages 54-54)

**1010**

SIZE

**GC**

PRODUCT CLASSIFICATION

Gear — Continuous Sleeve

**02**

TYPE

GC02 = Double Engagement

GC05 = Single Engagement/Floating Shaft

## Type G (pages 54-54 and pages 54-54)

**1010**

SIZE

**G**

PRODUCT CLASSIFICATION

Gear — Standard Flanged Sleeve

**20**

TYPE (Shrouded and Exposed Bolts)

G10/20 = Double Engagement (Shrouded/Exposed)

G51/52 = Single Engagement/Floating Shaft (Shrouded/Exposed)

GV10/20 = Vertical Double Engagement (Shrouded/Exposed)

GV51/52 = Vertical Single Engagement/Floating Shaft (Shrouded/Exposed)

G62 = Brakewheel Double Engagement (Exposed)

G63 = Disc Brake Double Engagement (Exposed)

G66 = Brakewheel Single Engagement (Exposed)

GL20 = Slide Double Engagement (Exposed)

GL52 = Slide Single Engagement/Floating Shaft (Exposed)

G70 = Disconnect Inching Drives

G72 = Disconnect (Exposed)

G31/32 = Spacer (Shrouded/Exposed)

GP20 = Insulated Double Engagement (Exposed)

GP52 = Insulated Single Engagement/Floating Shaft (Exposed)

GP82 = Insulated Rigid (Exposed)

G81/82 = Rigid (Shrouded/Exposed)

GV82 = Vertical Rigid (Exposed)

GR20 = Shear Pin (Exposed)

## Type G (pages 54-54 and pages 54-54)

**1080**

SIZE

**G**

PRODUCT CLASSIFICATION

Gear — Large Flanged Sleeve

**20**

TYPE (Exposed Bolts Only)

Type G20 = Double Engagement

Type G52 = Single Engagement/Floating Shaft

Type GV20 = Vertical Double Engagement

Type GV52 = Vertical Single Engagement/Floating Shaft

Type GL20 = Slide Double Engagement

Type G70 = Disconnect/Inching Drives

Type G32 = Spacer

Type G82 = Rigid

Type GV82 = Vertical Rigid

Type GR20 = Shear Pin

# Interchange Guide

## Flanged Sleeve Gear Couplings®

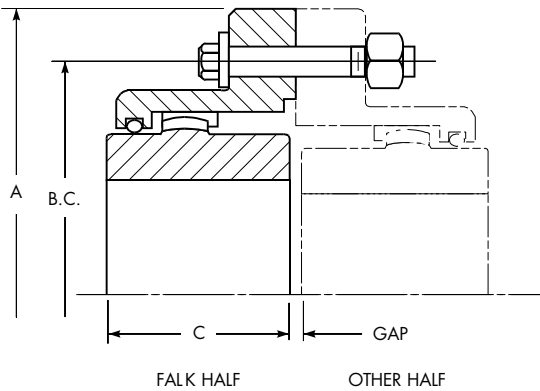

Exposed Bolt — Falk G20 (1000 Series) Half & Other Half

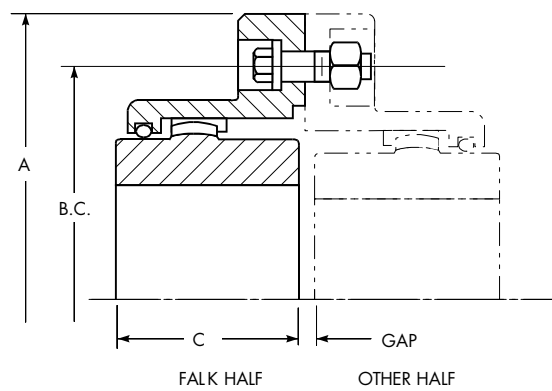

Shrouded Bolt — Falk G10 (1000 Series) Half & Other Half

### Exposed & Shrouded Bolts (in)

Common Dimensions				Falk G20 Exposed Falk G10 Shrouded (1000 Series)				Kop-Flex® (Koppers) HM (Exposed) HS (Shrouded)				Falk GF Steel Mill Exposed & Shrouded ①				Zurn® Amerigear-F Exposed & Shrouded (200 Series)						
A	Exposed		Shrouded		GAP	Size	Torque Rating (lb-in)	Max Bore Std Key	C	Size	Torque Rating (lb-in)	Max Bore	C	Size	Torque Rating (lb-in)	Max Bore	C	Size	Torque Rating (lb-in)	Max Bore	C	
	B.C.	Cap Screw Size & Qty	B.C.	Cap Screw Size & Qty																		
4.562	3.562	6-0.312	3.562	6-0.312	0.125	—	—	—	—	—	—	—	—	—	—	—	—	—	—	—	—	—
4.562	3.750	6-0.250	3.750	6-0.250	0.125	1010G	10,080	1.875	1.690	1HM/HS	7,560	1.625	1.687	1GF	7,600	1.625	1.69	—	—	—	—	
6.000	4.812	8-0.375	4.812	8-0.375	0.125	1015G	20,790	2.375	1.940	1-1/2 HM/HS	17,010	2.250	1.937	1-1/2GF	18,900	2.125	1.94	F201-1/2	17,010	2.250	1.937	
7.000	5.875	6-0.500	5.812	10-0.375	0.125	1020G	37,800	2.875	2.440	2HM/HS	31,500	2.750	2.437	2GF	31,500	2.750	2.44	F202	31,500	2.750	2.437	
8.375	7.125	6-0.625	7.000	10-0.500	0.187	1025G	66,150	3.625	3.030	2-1/2HM/HS	56,700	3.500	3.031	2-1/2GF	56,700	3.250	3.03	F202-1/2	53,550	3.500	3.031	
9.437	8.125	8-0.625	8.000	12-0.500	0.187	1030G	107,100	4.125	3.590	3HM/HS	88,200	4.000	3.593	3GF	101,000	4.000	3.59	F203	94,500	4.000	3.593	
11.000	9.500	8-0.750	9.281	12-0.625	0.250	1035G	163,800	4.875	4.190	3-1/2HM/HS	129,150	4.500	4.187	3-1/2GF	151,300	4.500	4.19	F203-1/2	141,750	4.500	4.187	
12.500	11.000	8-0.750	10.625	14-0.625	0.125	1040G	270,900	5.750	4.750	4HM/HS	204,750	5.500	4.750	4GF	236,000	5.375	4.75	F204	214,200	5.500	4.750	
13.625	12.000	10-0.750	11.750	14-0.625	0.312	1045G	371,700	6.750	5.310	4-1/2HM/HS	277,200	6.000	5.312	4-1/2GF	324,000	6.500	5.31	F204-1/2	324,450	6.250	5.312	
15.312	13.500	8-0.875	13.187	14-0.750	0.312	1050G	500,900	7.375	6.030	5HM/HS	384,300	6.875	6.031	5GF	441,000	7.000	6.03	F205	415,800	6.750	6.031	
16.750	14.500	14-0.875	14.437	16-0.750	0.312	1055G	655,200	8.250	6.620	5-1/2HM/HS	504,000	7.750	6.906	5-1/2GF	580,000	7.750	6.91	F205-1/2	551,250	7.620	6.625	
18.000	15.750	14-0.875	NA	NA	0.312	1060G	800,100	9.125	7.410	6HM	661,500	8.625	7.406	6GF	759,000	8.750	7.41	F206	749,700	8.620	7.406	
20.750	18.250	16-1	NA	NA	0.375	1070G	1,197,000	10.875	8.690	7HM	1,008,000	10.375	8.687	7GF	1,160,000	9.750	8.69	F207	1,033,200	10.250	8.687	

Lovejoy® Sier-Bath-F® Exposed & Shrouded ①				Kop-Flex (Waldron®) EB (Exposed) SB (Shrouded)				Falk G20 Exposed & Falk G20 Shrouded (10 Series)				Kop-Flex (Fast®) EB (Exposed) SB (Shrouded)				Renold® Metal Seal Exposed & Shrouded			
Size	Torque Rating (lb-in)	Max Bore	C	Size	Torque Rating (lb-in)	Max Bore	C	Size	Torque Rating (lb-in)	Max Bore	C	Size	Torque Rating (lb-in)	Max Bore	C	Size	Torque Rating (lb-in)	Max Bore	C
—	—	—	—	—	—	—	—	10G	5,040	1.375	1.500	—	—	—	—	—	—	—	—
F-1	7,560	1.625	1.687	1EB/SB	6,300	1.625	1.687	—	—	—	—	—	—	—	—	—	—	—	—
F-1-1/2	18,900	2.125	1.937	1-1/2EB/SB	15,120	2.187	2.062	15G	15,120	2.125	2.000	1-1/2EB/SB	17,010	1.625	1.937	1-1/2	2,016	1.750	1.937
F-2	31,500	2.750	2.437	2EB/SB	31,500	2.750	2.437	20G	31,500	2.625	2.437	2EB/SB	31,500	2.125	2.437	2	34,650	2.250	2.437
F-2-1/2	56,700	3.250	3.031	2-1/2EB/SB	56,700	3.250	3.031	25G	56,700	3.250	3.031	2-1/2EB/SB	56,700	2.750	3.031	2-1/2	59,850	2.750	3.031
F-3	94,500	4.000	3.593	3EB/SB	94,500	4.000	3.593	30G	94,500	3.750	3.593	3EB/SB	100,800	3.125	3.593	3	99,540	3.250	3.593
F-3-1/2	151,200	4.500	4.187	3-1/2EB/SB	144,900	4.750	4.187	35G	126,000	4.500	4.187	3-1/2EB/SB	148,050	3.750	4.187	3-1/2	149,940	3.750	4.187
F-4	220,500	5.375	4.750	4EB/SB	220,500	5.375	4.750	40G	189,000	5.125	4.750	4EB/SB	236,250	4.250	4.750	4	269,640	4.250	4.750
F-4-1/2	302,400	6.500	5.312	4-1/2EB/SB	302,400	6.000	5.375	45G	267,750	5.500	5.312	4-1/2EB/SB	318,150	4.750	5.312	4-1/2	369,810	4.750	5.312
F-5	434,700	7.000	6.031	5EB/SB	409,500	7.000	6.125	50G	368,550	6.375	6.031	5EB/SB	441,000	5.500	6.031	5	499,590	5.500	6.031
F-5-1/2	573,300	7.750	6.906	5-1/2EB/SB	535,500	7.750	6.625	55G	491,400	7.250	6.625	5-1/2EB/SB	579,600	5.875	6.906	5-1/2	650,160	6.250	6.906
F-6	749,700	8.750	7.406	6EB	693,000	8.750	7.375	60G	630,000	8.250	7.375	6EB	759,150	6.500	7.406	6	749,700	7.375	7.406
F-7	1,008,000	9.850	8.687	7EB	1,010,000	9.750	8.687	70G	1,008,000	9.000	8.687	7EB	1,159,200	8.000	8.687	7	926,100	8.750	8.687

① Based on the original Sier-Bath design. Component parts are interchangeable.

② Competitive complete half couplings are interchangeable because O.D., bolt circle, quantity and size are the same.

**IMPORTANT:** Exposed bolt sleeves will not mate to shrouded bolt designs regardless of the manufacturer. Shrouded bolt designs have a different bolt circle and a greater number of smaller diameter fasteners.

# Interchange Guide

## Continuous Sleeve Gear Couplings (in) ①

Size	Max Bore	Torque (lb-in)	RPM ②	O.D.	Overall Length	Gap	Size	Max Bore	Torque (lb-in)	RPM	O.D.	Overall Length	Gap	Size	Max Bore	Torque (lb-in)	RPM	O.D.	Overall Length	Gap
Falk							Lovejoy Sier-Bath							Kop-Flex Waldron						
–	–	–	–	–	–	–	7/8C	1.25	2,520	6,000	3.31	3.13	0.125	1-1/8PL	1.250	2,520	14,000	2.94	3.00	0.125
1010GC	1.875	10,800	5,300	3.50	3.50	0.125	1-1/2C	1.63	7,560	5,000	3.75	3.75	0.125	1-5/8PL	1.750	7,560	11,000	3.56	3.62	0.125
1015GC	2.375	20,790	4,300	4.30	4.08	0.125	2C	2.13	20,160	4,200	4.75	4.25	0.125	1-1/2P	2.19	15,120	9,000	4.12	4.25	0.125
1020GC	2.875	37,800	3,700	5.20	5.07	0.125	2-1/2C	2.63	30,240	3,750	5.50	4.75	0.250	2P	2.75	31,500	7,200	5.19	5.00	0.125
–	–	–	–	–	–	–	3C	3.13	50,400	3,000	6.63	5.50	0.250	–	–	–	–	–	–	–
1025GC	3.625	66,150	3,300	6.44	6.25	0.188	3-1/2C	3.63	88,200	2,800	7.50	8.75	0.250	2-1/2P	3.25	56,700	6,000	6.00	6.25	0.188
1030GC	4.125	107,100	2,900	7.50	7.37	0.188	4C	4.13	126,000	2,400	8.75	9.00	0.250	3P	4.00	94,500	5,200	7.00	7.38	0.188
1035GC	4.875	163,800	2,600	8.50	8.63	0.250	4-1/2C	4.75	183,960	2,200	9.50	10.25	0.250	3-1/2P	4.75	144,900	4,600	8.25	8.62	0.250
–	–	–	–	–	–	–	5C	5.75	270,900	2,100	10.75	12.25	0.250	4P	5.38	220,500	4,200	9.25	9.75	0.250
Falk							Zurn							System Components						
–	–	–	–	–	–	–	201CS	1.250	3,150	9,800	2.69	2.88	0.125	8S	1.310	4,410	9,600	2.81	1.41	0.094
1010GC	1.875	10,800	5,300	3.50	3.50	0.125	201-1/4CS	1.625	7,560	8,900	3.19	3.50	0.125	10S	1.630	9,765	7,560	3.44	1.84	0.094
–	–	–	–	–	–	–	–	–	–	–	–	–	–	12S	1.940	13,860	6,900	3.94	1.84	0.094
1015GC	2.375	20,790	4,300	4.30	4.08	0.125	201-1/2CS	2.250	17,010	7,700	4.38	4.00	0.125	15S	2.130	19,530	6,600	4.13	2.78	0.125
1020GC	2.875	37,800	3,700	5.20	5.07	0.125	202CS	2.750	31,500	6,200	5.38	5.00	0.125	20S	2.750	32,130	5,280	5.13	3.19	0.125
1025GC	3.625	66,150	3,300	6.44	6.25	0.188	202-1/2CS	3.500	53,500	6,000	6.50	6.25	0.188	25S	3.250	56,700	4,500	6.03	3.88	0.188
–	–	–	–	–	–	–	–	–	–	–	–	–	–	30S	3.750	95,760	3,960	6.84	4.53	0.188
1030GC	4.125	107,100	2,900	7.50	7.37	0.188	203CS	4.000	94,500	5,200	7.44	7.37	0.188	35S	4.250	151,200	3,480	7.88	5.41	0.250
1035GC	4.875	163,800	2,600	8.50	8.63	0.250	203-1/2CS	4.500	141,750	4,400	8.32	8.63	0.250	40S	5.000	226,800	2,940	9.13	5.59	0.250
–	–	–	–	–	–	–	204CS	5.500	214,200	3,550	9.86	9.75	0.250	45S	5.500	333,900	2,640	10.41	6.66	0.312

① Couplings are functionally interchangeable only; components are not interchangeable. Verify interchange against specific application selection criteria.

② Refer to the Factory for higher speeds.







## Why Choose Rexnord?

When it comes to providing highly engineered products that improve productivity and efficiency for industrial applications worldwide, Rexnord is the most reliable in the industry. Commitment to customer satisfaction and superior value extend across every business function.

### Delivering Lowest Total Cost of Ownership

The highest quality products are designed to help prevent equipment downtime and increase productivity and dependable operation.

### Valuable Expertise

An extensive product offering is accompanied by global sales specialists, customer service and maintenance support teams, available anytime.

### Solutions to Enhance Ease of Doing Business

Commitment to operational excellence ensures the right products at the right place at the right time.

## REXNORD

### Rexnord Corporation

Rexnord is a growth-oriented, multi-platform industrial company with leading market shares and highly trusted brands that serve a diverse array of global end markets.

### Process and Motion Control

The Rexnord Process & Motion Control platform designs, manufactures, markets and services specified, highly engineered mechanical components used within complex systems where our customers' reliability requirements and the cost of failure or downtime are extremely high.

### Water Management

The Rexnord Water Management platform designs, procures, manufactures and markets products that provide and enhance water quality, safety, flow control and conservation.

# Morskate®

Gedreven door techniek



Any questions? Please contact us.

**Morskate Aandrijvingen BV**

Oosterveldsingel 47A  
7558 PJ Hengelo (Ov)  
The Netherlands

**NL**

T +31 (0)74 - 760 11 11  
info@morskateaandrijvingen.nl  
www.morskateaandrijvingen.nl

**DE**

T +49 692 - 222 34 95  
info@morskateantriebstechnik.de  
www.morskateantriebstechnik.de

**EN**

T +31 (0)74 - 760 11 11  
info@morskatedrivetechnology.com  
www.morskatedrivetechnology.com