

## Installation and Operating Instruction for Complete Freewheels FA

E 08.651 e



Any questions? Please contact us.

### Morskate Aandrijvingen BV

Oosterveldsingel 47A  
7558 PJ Hengelo (Ov)  
The Netherlands

NL  
T +31 (0)74 - 760 11 11  
info@morskateaandrijvingen.nl  
www.morskateaandrijvingen.nl

DE  
T +49 692 - 222 34 95  
info@morskateantriebstechnik.de  
www.morskateantriebstechnik.de

EN  
T +31 (0)74 - 760 11 11  
info@morskatedrivetechnology.com  
www.morskatedrivetechnology.com

<b>RINGSPANN</b>	<b>Installation and Operating Instruction for Complete Freewheels FA</b>	<b>E 08.651 e</b>			
Stand: 28.01.2011	Version : 04	gez.: Su	gepr.: Ei	Seitenzahl: 7	Seite: 2

---

## Important

Please read these instructions carefully before installing and operating the product. Your particular attention is drawn to the notes on safety.

These installation and operating instructions are valid on condition that the product meets the selection criteria for its proper use. Selection and design of the product is not the subject of these installation and operating instructions.

Disregarding or misinterpreting these installation and operating instructions invalidates any product liability or warranty by RINGSPANN; the same applies if the product is taken apart or changed.

These installation and operating instructions should be kept in a safe place and should accompany the product if it is passed on to others – either on its own or as part of a machine – to make it accessible to the user.

---

## Safety Notice

- Installation and operation of this product should only be carried out by skilled personnel.
- Repairs may only be carried out by the manufacturer or accredited RINGSPANN agents.
- If a malfunction is indicated, the product or the machine into which it is installed, should be stopped immediately and either RINGSPANN or an accredited RINGSPANN agent should be informed.
- Switch off the power supply before commencing work on electrical components.
- Rotating machine elements must be protected by the purchaser to prevent accidental contact.
- Supplies abroad are subject to the safety laws prevailing in those countries.

<b>RINGSPANN</b>	<b>Installation and Operating Instruction for Complete Freewheels FA</b>			<b>E 08.651 e</b>	
Stand: 28.01.2011	Version : 04	gez.: Su	gepr.: Ei	Seitenzahl: 7	Seite: 3

## 1. General introduction

Complete Freewheels FA are machine elements with particular characteristics:

- In one direction of rotation there is no contact between the inner and outer ring; the freewheel is in freewheeling operation.
- In the other direction of rotation there is contact between the inner and outer ring; in this direction it is possible to transmit high torque.

Complete Freewheels FA are used as:

- Backstops
- Indexing Freewheels



### Caution!

As Freewheels can be used as safety components, it is important to observe these installation and operating instructions carefully.

## 2. Applications of Freewheels

### 2.1 Application as Backstop

Freewheels are used as backstops if reverse rotation of the operating direction is to be prevented. In many machines and installations, for technical safety or functional reasons, it is necessary to ensure that you are working in just one specified direction of rotation. This is why there are legal stipulations requiring a mechanical safety device for the operation of, e.g. conveyor systems.

The normal operating mode of a backstop is freewheeling operation; the locking (torque transmission) is performed at zero speed. The immediate engagement of the clamping elements ensures the required high operating safety.

Freewheels FA can be used as backstops for applications with low speed in freewheeling operation.

### 2.2 Application as Indexing Freewheel

The indexing freewheel transmits a back-and-forth motion into a stepped rotation (indexed feed). The RINGSPANN indexing freewheel works precisely and quietly and enables an infinitely adjustable setting of the feed.

Freewheels FA can be used as indexing freewheels for applications with a low to medium total number of actuation.

### 3. Design

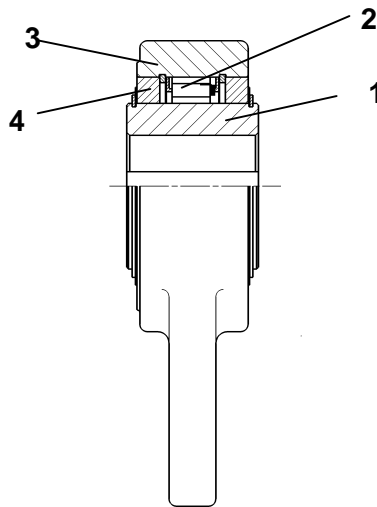

Fig. [1]

Die Complete Freewheels FA are designed as shown in Fig. [1]. The essential functional components are the inner ring (1), the sprags (2), the outer ring (3), the sleeve bearings (4) and the lubricant.

### 4. Types

Complete Freewheels FA are available in 3 different types:

#### 4.1 Standard type

This type is designed for universal use.

It is identified by the suffix "F" at the end of the product designation.

Example: FA 57... F

#### 4.2. Type with RIDUVIT®

This type is designed for extended service life using sprag coating

It is identified by the suffix "T" at the end of the product designation.

Example: FA 57... T

#### 4.3. Type with P-grinding

This type is designed for extended service life and indexing accuracy when used as indexing freewheel.

It is identified by the suffix "P" at the end of the product designation.

Example: FA 57... P



#### **Please note!**

Further information especially on design, function and selection, permissible torques or permissible speeds of these freewheels is provided in RINGSPANN Catalog 84 "Freewheels". Please contact RINGSPANN GmbH if you need assistance.

<b>RINGSPANN</b>	<b>Installation and Operating Instruction for Complete Freewheels FA</b>			<b>E 08.651 e</b>	
Stand: 28.01.2011	Version : 04	gez.: Su	gepr.: Ei	Seitenzahl: 7	Seite: 5

## 5. General instructions



### **Danger to life and limb!**

**Do not release the lever arm for the backstop until the machine or system is load-free.**

**Release of the freewheel under load conditions results in uncontrolled reverse movement of the machine or system.**

**Explosive destruction of machine or system components may result.**



### **Caution!**

The maximum permissible freewheel torque must not be exceeded due to torque peaks in specific applications.

The maximum freewheel torque should be calculated according to RINGSPANN Catalog 84. Please contact RINGSPANN if you need assistance.

**Freewheel damage resulting by excessive torque peaks impair component function and can result in excessive overheating of the freewheel!**



### **Caution!**

The built-in bearings must not be clamped. They are not designed for axial and tilting forces. It is essential to ensure that bearings will not be damaged.

**Bearing damage can result in overheating and the impairment of freewheel function!**



### **Caution!**

Torsion vibrations (amplitudes and frequencies which result in engagement and release of the freewheel in rapid succession) must be avoided.

**Torsion vibrations can result in overheating and the impairment of freewheel function!**

<b>RINGSPANN</b>	<b>Installation and Operating Instruction for Complete Freewheels FA</b>			<b>E 08.651 e</b>	
Stand: 28.01.2011	Version : 04	gez.: Su	gepr.: Ei	Seitenzahl: 7	Seite: 6

## 6. Condition at delivery

The freewheels are delivered ready to install and filled with grease. They are packed in anti-corrosion paper..

## 7. Storage

Storage max. 1 year in dry rooms.

## 8. Technical requirements for safe operation

The bore in the inner ring normally has a tolerance of ISO H7. The tolerance of the shaft must be in this case ISO h6 or j6.

The key must have back play and may have only minimal width oversize, as otherwise the inner ring may be deformed.

When the freewheel is used as a backstop, the lever arm serves as a torque support. It must not be clamped tightly but must have 0.5 – 2 mm axial and circumferential play.

When the freewheel is used as an indexing freewheel the lever arm serves and an indexing lever. It must be allowed to expose the bearings in the freewheel to tension.

The lever arm is not hardened and thus allows for the drilling of bores by the customer.



### Caution!

**Clamping the lever arm tightly when the freewheel is used as a backstop can result in an impairment of function and excessive overheating of the freewheel!**

**Exposing the bearings in the freewheel to tension from the lever arm during use as an indexing freewheel can result in an impairment of function and excessive overheating of the freewheel!**



### Caution!

When drilling bores in the lever arm, it is important to ensure than no metal particles or coolants intrude into the freewheel!

**Metal particles or coolants can result in an impairment of function and excessive overheating of the freewheel!**

<b>RINGSPANN</b>	<b>Installation and Operating Instruction for Complete Freewheels FA</b>			<b>E 08.651 e</b>	
Stand: 28.01.2011	Version : 04	gez.: Su	gepr.: Ei	Seitenzahl: 7	Seite: 7

## 9. Installation

The direction of machine or system rotation must be determined prior to freewheel installation. Mark this direction with an arrow on the shaft to which the inner ring of the freewheel is to be mounted.

Ensure that the freewheeling direction of the freewheel matches the direction marked on the shaft.



### Caution!

When a freewheel is used as a backstop, the drive must not be started in the direction opposite the freewheeling direction of the freewheel, as otherwise the freewheel may be destroyed!



### Caution!

Please observe the instructions in Section 8 "Technical requirements for safe operation" of these installation and operating instructions!

Apply only uniformly distributed pressure (without heating) to the front face of the inner ring when mounting the freewheel to the shaft.

Secure the freewheel to the shaft axially with a safety ring or a screw with washer.

Support the lever arm with a bolt or an limit stop.

## 10. Inspection prior to commissioning

Turn the freewheel-outer ring against to the freewheel-inner ring by hand in the freewheeling direction (freewheeling operation). If the freewheel turns roughly, apply a light hammer blow to the outer ring while turning the freewheel by hand in the freewheeling direction.

## 11. Maintenance

Complete Freewheels FA are pre-greased for the life of the freewheel (KLÜBER ISOFLEX LDS 18 Special A). They are maintenance-free and require no re-lubrication in most cases.