

Installation and Operating Instruction for Complete Freewheels FBE

E 08.644 e

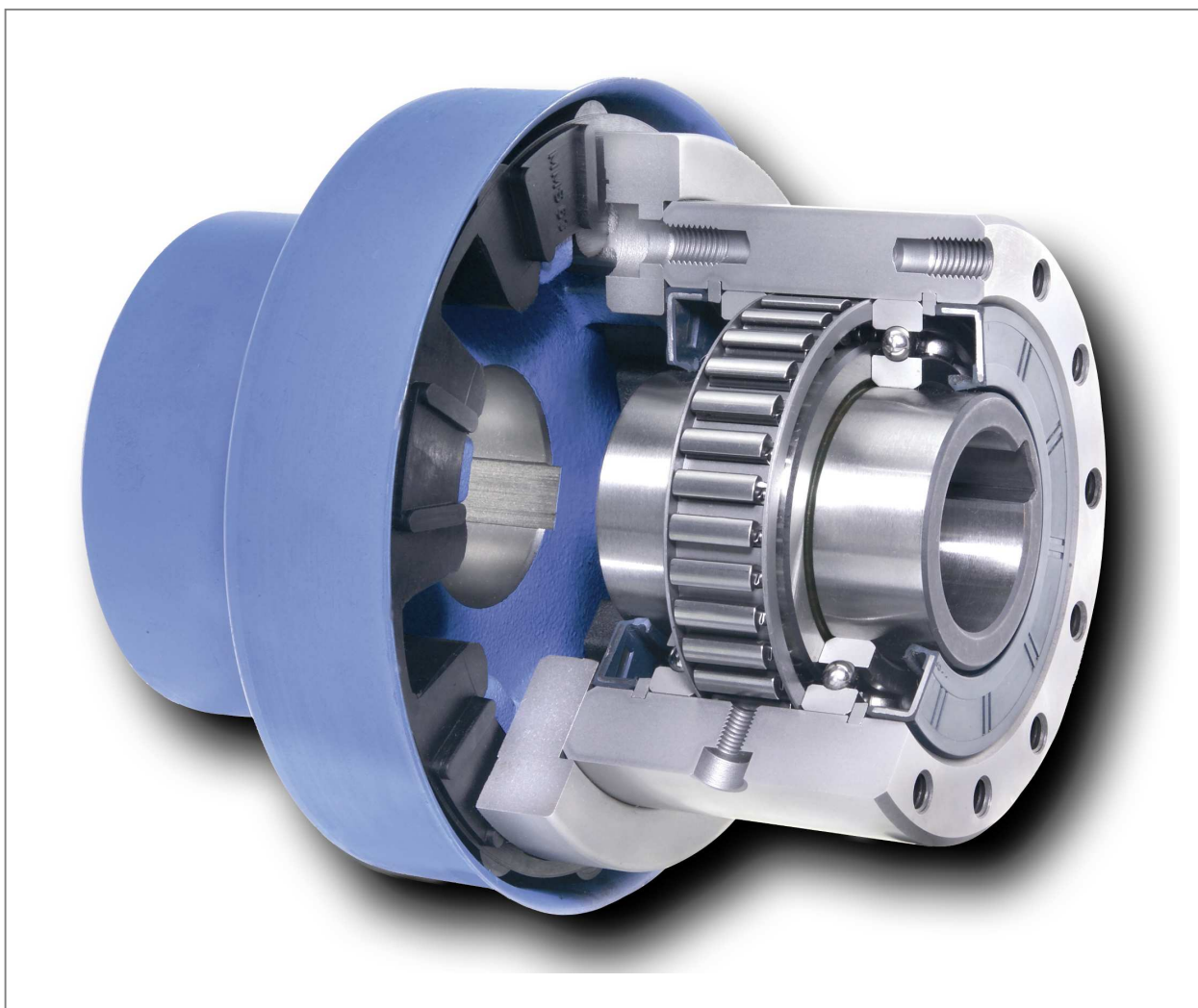

Any questions? Please contact us.

Morskate Aandrijvingen BV

Oosterveldsingel 47A
7558 PJ Hengelo (Ov)
The Netherlands

NL
T +31 (0)74 - 760 11 11
info@morskateaandrijvingen.nl
www.morskateaandrijvingen.nl

DE
T +49 692 - 222 34 95
info@morskateantriebstechnik.de
www.morskateantriebstechnik.de

EN
T +31 (0)74 - 760 11 11
info@morskatedrivetechnology.com
www.morskatedrivetechnology.com

RINGSPANN	Installation and Operating Instruction for Complete Freewheels FBE	E 08.644 e			
Issue: 08.06.2011	version : 04	drawn.: Su	checked.: Ei	pages: 12	page: 2

Important

Please read these instructions carefully before installing and operating the product. Your particular attention is drawn to the notes on safety.

These installation and operating instructions are valid on condition that the product meets the selection criteria for its proper use. Selection and design of the product is not the subject of these installation and operating instructions.

Disregarding or misinterpreting these installation and operating instructions invalidates any product liability or warranty by RINGSPANN; the same applies if the product is taken apart or changed.

These installation and operating instructions should be kept in a safe place and should accompany the product if it is passed on to others – either on its own or as part of a machine – to make it accessible to the user.

Safety Notice

- Installation and operation of this product should only be carried out by skilled personnel.
- Repairs may only be carried out by the manufacturer or accredited RINGSPANN agents.
- If a malfunction is indicated, the product or the machine into which it is installed, should be stopped immediately and either RINGSPANN or an accredited RINGSPANN agent should be informed.
- Switch off the power supply before commencing work on electrical components.
- Rotating machine elements must be protected by the purchaser to prevent accidental contact.
- Supplies abroad are subject to the safety laws prevailing in those countries.

RINGSPANN	Installation and Operating Instruction for Complete Freewheels FBE			E 08.644 e	
Issue: 08.06.2011	version : 04	drawn.: Su	checked.: Ei	pages: 12	page: 3

Contents

1. General introduction
2. Applications of Freewheels
3. Design
4. Types
5. General instructions
6. Condition of delivery
7. Technical requirements for safe operation
8. Installation
 - 8.1 Alignment of the shaft coupling
9. Inspection prior to commissioning
10. Maintenance
11. Lubricants

1. General introduction

Complete Freewheels FBE are machine elements with particular characteristics:

- In one direction of rotation there is no contact between the inner and outer ring; the freewheel is in freewheeling operation.
- In the other direction of rotation there is contact between the inner and outer ring; in this direction it is possible to transmit high torque.

Complete Freewheels FBE are used as:

- Overrunning Clutches



Caution!

As Freewheels can be used as safety components, it is important to observe these installation and operating instructions carefully.

2. Applications of Freewheels

Application as Overrunning Clutch

The overrunning clutch engages machines or machine parts and automatically interrupts their contact as soon as the driven part of the overrunning clutch is turned faster than the driving part. In many cases, this can replace a more expensive externally actuated clutch.

With overrunning clutches the engagement take place in the driving operation (torque transmission), while in freewheeling operation the torque transmission between the inner and outer ring is interrupted. In driving operation the speeds of the inner and outer ring are equal, while in freewheeling operation they are different.

3. Design

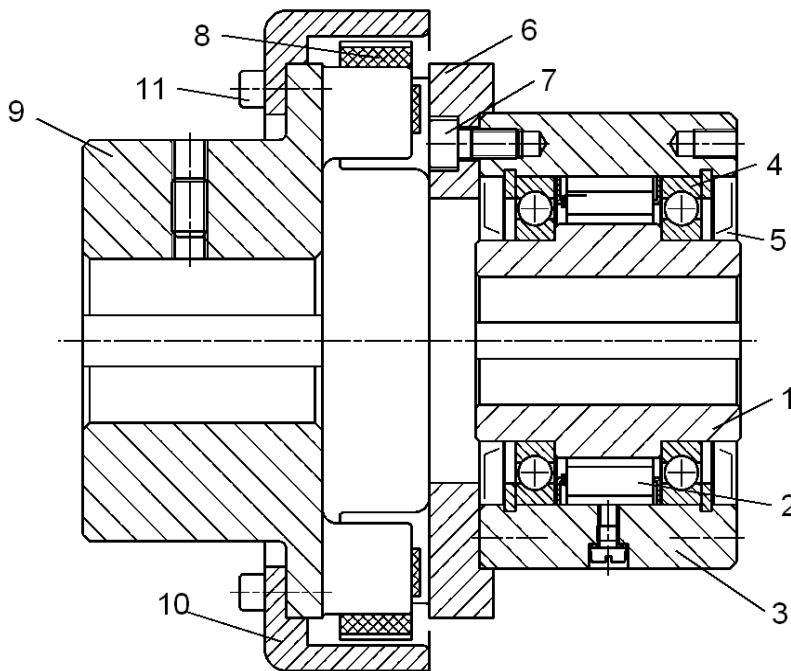

Fig. [1]

Complete Freewheels FBE are designed as shown in Fig. [1]. The essential functional components are the inner ring (1), the sprags (2), the outer ring (3), the bearings (4), the seals (5), the coupling flange on the freewheel side (6), the mounting screws (7), the flexible disk (8), the coupling hub (9), the retaining cap (10) with fastening screws (11) and the lubricant.

4. Types

Complete Freewheels FBE are available in 4 different types.

4.1 Standard type

This type is designed for universal use.

It is identified by the suffix "F" at the end of the product designation.

Example: FBE 57 .F

4.2. Type with RIDUVIT®

This type is designed for extended service life using sprag coating

It is identified by the suffix "T" at the end of the product designation.

Example: FBE 57 ..T

4.3. Type with sprag lift-off Z

This type is designed for extended service life using sprag lift-off at high speed rotating outer ring.

It is identified by the suffix "Z" at the end of the product designation.

Example: FBE 57 ..Z

RINGSPANN	Installation and Operating Instruction for Complete Freewheels FBE			E 08.644 e	
Issue: 08.06.2011	version : 04	drawn.: Su	checked.: Ei	pages: 12	page: 5

4.4. Type with sprag lift-off X

This type is designed for extended service life using sprag lift-off at high speed rotating inner ring.

It is identified by the suffix "X" at the end of the product designation.

Example: FBE 57 .X



Please note!

Further information especially on design, function and selection, permissible torques or permissible speeds of these freewheels is provided in RINGSPANN catalog 84 "Freewheels". Please contact RINGSPANN GmbH if you need assistance.

5. General instructions



Caution!

Reliable torque transmission between the freewheel is guaranteed only if the maximum permissible speed in driving operation of the freewheel is not exceeded.

Operation at speeds in excess of the speeds permitted for the different operating modes can result in damage and overheating of the freewheel!



Caution!

The maximum permissible freewheel torque must not be exceeded due to torque peaks in specific applications.

The maximum freewheel torque should be calculated according to RINGSPANN catalog 84. Please contact RINGSPANN if you need assistance.

Freewheel damage resulting by excessive torque peaks impair component function and can result in excessive overheating of the freewheel!



Caution!

If the system is exposed to axial and/or radial loads, the roller bearings in the freewheel should be checked with reference to the rules for calculation provided by the bearing manufacturer. It is essential to ensure that bearings will not be damaged.

Bearing damage can result in overheating and the impairment of freewheel function!

RINGSPANN	Installation and Operating Instruction for Complete Freewheels FBE	E 08.644 e		
Issue: 08.06.2011	version : 04	drawn.: Su	checked.: Ei	pages: 12 page: 6

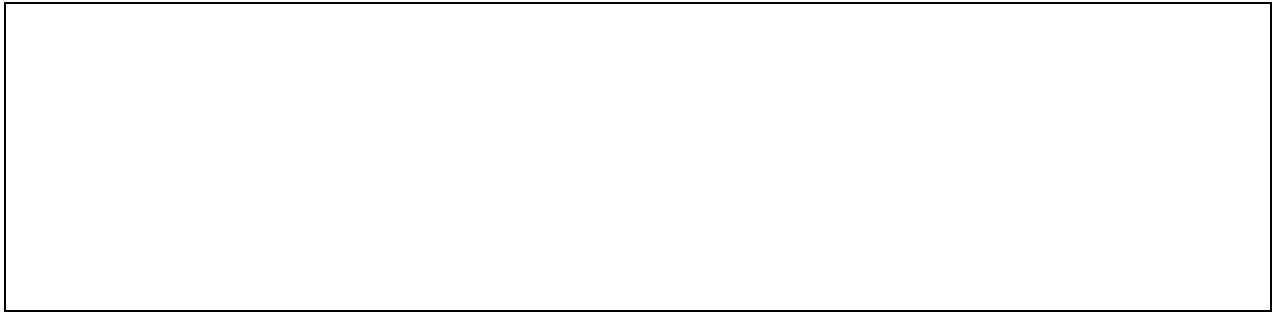

Caution!

Torsion vibrations (amplitudes and frequencies which result in engagement and release of the freewheel in rapid succession) must be avoided.

Torsion vibrations can result in overheating and the impairment of freewheel function!



Caution!

Seals must be correctly installed during the entire service life of the freewheel and must not be excessively worn. Seals should be replaced as needed.

Seal damage can result in overheating and the impairment of freewheel function!



Caution!

Operation of freewheels with centrifugal sprag lift-off below the lift-off speed results in sprag wear. Occasional start and stop operations during operation below lift-off speed for periods of less than 20 second are permitted.

Excessive sprag wear can result in overheating and the impairment of freewheel function!

6. Condition at delivery

The freewheels are delivered oil-filled and ready for installation. They are packed in anti-corrosion paper.

The shaft coupling is delivered loose. According to the direction of rotation wanted it may be fixed either on the left or right side of the freewheel.

RINGSPANN	Installation and Operating Instruction for Complete Freewheels FBE			E 08.644 e	
Issue: 08.06.2011	version : 04	drawn.: Su	checked.: Ei	pages: 12	page: 7

7. Technical requirements for safe operation

The bore in the inner ring normally has a tolerance of ISO H7. The tolerance of the shaft must be in this case ISO h6 or j6.

The key must have back play and may have only minimal width oversize, as otherwise the inner ring may be deformed.

The bore of the coupling hub usually has the ISO tolerance H7. The RINGSPANN recommendation for shaft tolerance is ISO h6 or j6.

8. Installation

The direction of machine or system rotation must be determined prior to freewheel installation.

Mark this direction with an arrow on the shaft to which the inner ring of the freewheel is to be mounted.

Ensure that the freewheeling direction of the freewheel matches the direction marked on the shaft.

Apply only uniformly distributed pressure (without heating) to the front face of the inner ring when mounting the freewheel to the shaft.

If the freewheel is mounted with its outer ring on the centering device of the customer, this operation must be performed by applying uniform pressure to the front face of the outer ring around the entire circumference.



Caution!

The freewheel may not be driven onto the shaft by applying hammer blows, as the built-in roller bearings may be damaged in the process!

Secure the inner ring of the freewheel along the axial plane of the shaft.

The flange of the shaft coupling is screwed to the freewheel. Tightening torques are to be selected in accordance with VDI 2230 on the basis of the actual friction coefficients in a given case.

Then the other parts of the shaft coupling mounted.

During assembly of the elastic elements are important to ensure that the coupling halves can not be mounted close to the elastic elements are not exposed to lateral pressure and the clutch remains in operation axial yielding. Likewise the coupling halves are not too far apart, so that the packages have rubber over the entire width between the coupling claws.

For installation help push over the retaining cap inlaid with semi-tunnel before they can be on the periphery with talcum powder or soap (no fat or oil coated). As an auxiliary tool to slide the retaining cap is a threaded rod may be used.

For the sizes FBE 37 to FBE 127 for screwing the screws retaining cap may only be used with the associated washers to DIN 7349.

8.1 Alignment of the shaft coupling

After the freewheel and the shaft coupling are inserted, the adjustment of the shaft coupling must be accomplished as follows with solved and pushed back retaining cap:

a) Radial Alignment

The radial alignment R of the respective coupling halves has to be determined at least four measuring points each displaced by 90° and to be reduced to a minimum by aligning the connected machines (Maximum values see following table). If the shafts can be rotated, after each measurement the shafts with the hubs have to be turned by 90° in order to ensure that the four measurements are always conducted at the same point of the coupling.

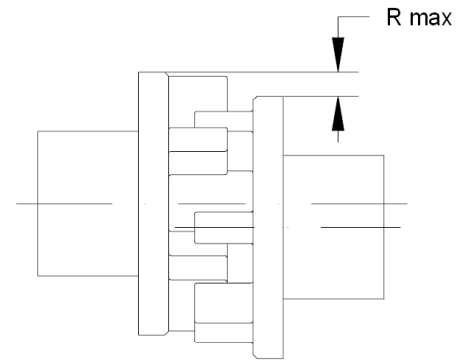

b) Angular Alignment

After the same measuring procedure caused extent deviation W is to be determined by the circumferential misalignment, the permissible maximum value, according to following table, not to be exceeded may.

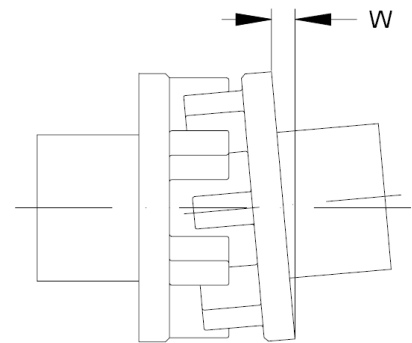

c) Axial Alignment

The axial fitting dimension S is to be likewise controlled at four measuring points shifted by 90°, it must lie within the tolerance values indicated down.

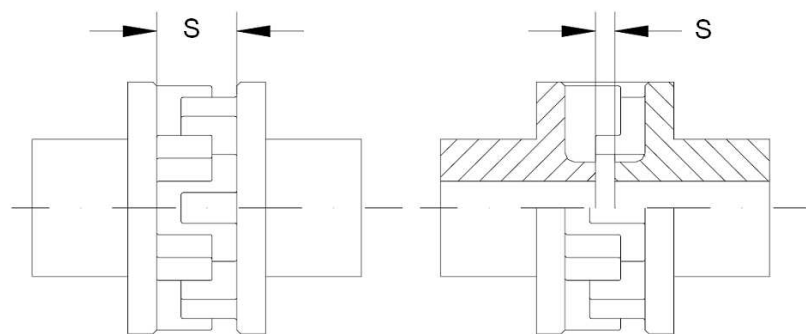

to size 200

from size 200

Freewheel size	24	29	37	44	57	72	82	107	127	140	200	270	340	440
R _{max.} [mm]	0,1 5	0,1 5	0,1 5	0,1 5	0,2 0	0,2 0	0,2 0	0,2 0	0,3 0	0,3 0	0,4 0	0,4 5	0,5 0	0,6 0
W _{max.} [mm]	0,2 5	0,2 5	0,2 5	0,3 0	0,3 0	0,4 0	0,5 0	0,5 0	0,7 0	0,8 0	1,0 0	1,0 0	1,2 0	1,5 0
S ± 1 [mm]	18	20	17	19	26	30	35	41	56	64	85	8	10	15

Before commissioning of the coupling bolts with a torque wrench with respect to their correct torque check. If you want an extra screws securing, we recommend using anaerobic adhesives (such as Loctite, etc.). Tightening torque in the following table:

Thread diameter	M 6	M 8	M 10	M 12	M 16	M 20	M 24	M 27	M 30
Tightening torque [Nm]	10	25	49	86	210	410	710	1050	1450

9. Inspection prior to commissioning

The oil level must be checked prior to initial operation of the freewheel. (see Fig [2]).

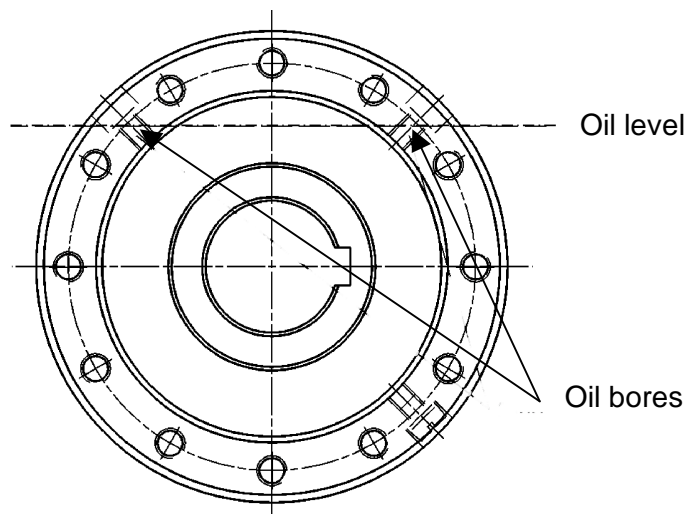

Fig. [2]

Three oil bores on the circumference of the freewheel are provided for this purpose.

- Turn the outer ring of the freewheel until two of the oil bores point upward at 45° angle to the middle axis.
- Remove the screws from these two oil bores and take out the gaskets.
- Pour oil into one of the oil bores until its runs out of the opposite bore. See the oil selection table in Section 11 "Lubricants" for the appropriate grade of oil.
- Close the two oil bores with the gaskets and screws.
- Turn the freewheel-outer ring against to the freewheel-inner ring by hand in the freewheeling direction (freewheeling operation). If the freewheel turns roughly, apply a light hammer blow to the outer ring while turning the freewheel by hand in the freewheeling direction.



Caution!

A certain degree of friction is caused by the seals. This is reduced after a short operation time.

RINGSPANN	Installation and Operating Instruction for Complete Freewheels FBE	E 08.644 e		
Issue: 08.06.2011	version : 04	drawn.: Su	checked.: Ei	pages: 12 page: 10



Caution!

All bolted connections should be checked prior to commissioning and after a test run!

10. Maintenance



Caution!

The first oil change must be performed after 20 hours of operation!

During the first oil change, all particles accumulated during the “running in” procedure should be removed from the freewheel. That is why this oil change is required to ensure the service life of the freewheel.

Subsequent oil changes must be performed after every 2,000 operating hours, at a minimum



Information!

If oil is changed at longer intervals, we recommend using the synthetic lubricant MOBIL SHC 626.

If this lubricant is used, it must be changed after every 4,000 operating hours.

When speed differences between the inner ring and outer ring of less than 100 min^{-1} longer oil change intervals are allowed after consultation.

Oil change procedure:

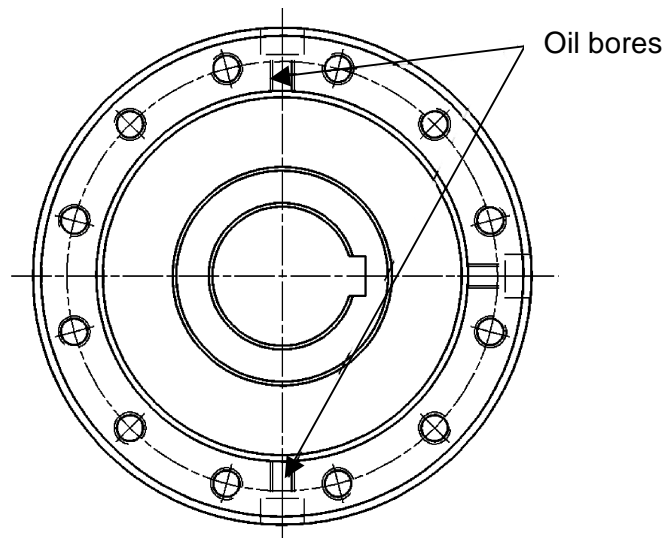

Fig. [3]

- Turn the freewheel until the two of the three oil bores are positioned one above the other (see Fig. [3]).
- Remove the screws and gaskets from all three oil bores.
- Collect and dispose of the old oil in accordance with applicable regulations.
- Clean the freewheel with cleaning oil and dispose of the cleaning oil in accordance with applicable regulations.
- Close the lower oil bore with a gasket and screw.
- Turn the outer ring of the freewheel until the two open bores point upward at 45° angle to the middle axis (see Fig. [2]).
- Pour oil into one of the oil bores until its runs out of the opposite bore. See the oil selection table in Section 11 "Lubricants" for the appropriate grade of oil.
- Close the two oil bores with the gaskets and screws.



Caution!

If seal problems occur (leakage) during operation, the machine or system must be shut down immediately. Determine the cause of the leak and replace the freewheel if necessary!

11. Lubricants

The freewheels are delivered oil-filled. Please follow the instructions in Section 9 before commissioning. We recommend the following grades of oil for lubrication or oil changes:

Oil table			
Ambient temperature	For ambient temperatures from 0° to 50° C	For ambient temperatures from - 15° to + 15° C	For ambient temperatures from - 40° to 0° C
Kinematic viscosity at 40° C, ISO-VG	46/68 [mm²/s]	32 [mm²/s]	10 [mm²/s]
AGIP	OSO 46/68	OSO 32	OSO 10
ARAL	VITAM GF 46/68	VITAM GF 32	VITAM GF 10
BP	ENERGOL HLP 46/68	ENERGOL HLP 32	AERO HYDRAULIC 1
CASTROL	VARIO HDX	VARIO HDX	ALPHASYNTH 15
CHEVRON	EP HYDRAULIC OIL 46/68	EP HYDRAULIC OIL 32	HYJET IV
DEA	ASTRON HLP 46	ASTRON HLP 32	ASTRON HLP 10
ELF	ELFOLNA 46	ELFOLNA 32	ELF AVIATION HYDRAULIC OIL 20
ESSO	NUTO H 46/68	NUTO H 32	UNIVIS J 13
KLÜBER	LAMORA HLP 46/68	LAMORA HLP 32	Klüberoil 4 UH1-15
MOBIL	D.T.E. 25/26	D.T.E. 24	AERO HF A
SHELL	TELLUS OIL 46/68	TELLUS OIL 32	TELLUS OIL 10
Other manufacturers	Gearbox- or hydraulic oils without solid lubricants ISO-VG 46/68	Gearbox- or hydraulic oils without solid lubricants ISO-VG 32; Automatic transmission fluids [ATF]	Gearbox- or hydraulic oils without solid lubricants ISO-VG 10; Note setting point! Aviation hydraulic oils ISO-VG 10

Please contact us if temperatures exceed + 50 °C or fall below – 40 °C..



Caution!

Oils that contain friction-reducing additives like molybdenum disulfide or the like, may only be used with our authorisation.