

Installation and Operating Instruction for Complete Freewheels FKh

E 08.602 e



Any questions? Please contact us.

Morskate Aandrijvingen BV

Oosterveldsingel 47A
7558 PJ Hengelo (Ov)
The Netherlands

NL

T +31 (0)74 - 760 11 11
info@morskateaandrijvingen.nl
www.morskateaandrijvingen.nl

DE

T +49 692 - 222 34 95
info@morskateantriebstechnik.de
www.morskateantriebstechnik.de

EN

T +31 (0)74 - 760 11 11
info@morskatedrivetechnology.com
www.morskatedrivetechnology.com

RINGSPANN	Installation and Operating Instruction for Complete Freewheels FK_h	E 08.602 e			
Issue: 08.07.2011	version : 04	drawn.: Su	checked.: Ei	pages: 10	page: 2

Important

Please read these instructions carefully before installing and operating the product. Your particular attention is drawn to the notes on safety.

These installation and operating instructions are valid on condition that the product meets the selection criteria for its proper use. Selection and design of the product is not the subject of these installation and operating instructions.

Disregarding or misinterpreting these installation and operating instructions invalidates any product liability or warranty by RINGSPANN; the same applies if the product is taken apart or changed.

These installation and operating instructions should be kept in a safe place and should accompany the product if it is passed on to others – either on its own or as part of a machine – to make it accessible to the user.

Safety Notice

- Installation and operation of this product should only be carried out by skilled personnel.
- Repairs may only be carried out by the manufacturer or accredited RINGSPANN agents.
- If a malfunction is indicated, the product or the machine into which it is installed, should be stopped immediately and either RINGSPANN or an accredited RINGSPANN agent should be informed.
- Switch off the power supply before commencing work on electrical components.
- Rotating machine elements must be protected by the purchaser to prevent accidental contact.
- Supplies abroad are subject to the safety laws prevailing in those countries.

RINGSPANN	Installation and Operating Instruction for Complete Freewheels FK_h			E 08.602 e	
Issue: 08.07.2011	version : 04	drawn.: Su	checked.: Ei	pages: 10	page: 3

1. General introduction

Complete Freewheels FK_h are machine elements with particular characteristics:

- In one direction of rotation there is no contact between the inner and outer ring; the freewheel is in freewheeling operation.
- In the other direction of rotation there is contact between the inner and outer ring; in this direction it is possible to transmit high torque.

Complete Freewheels FK_h are used as:

- Overrunning Clutches



Caution!

As Freewheels can be used as safety components, it is important to observe these installation and operating instructions carefully.

2. Applications of Freewheels

Application as Overrunning Clutch

The overrunning clutch engages machines or machine parts and automatically interrupts their contact as soon as the driven part of the overrunning clutch is turned faster than the driving part. In many cases, this can replace a more expensive externally actuated clutch.

With overrunning clutches the engagement take place in the driving operation (torque transmission), while in freewheeling operation the torque transmission between the inner and outer ring is interrupted. In driving operation the speeds of the inner and outer ring are equal, while in freewheeling operation they are different.

3. Design

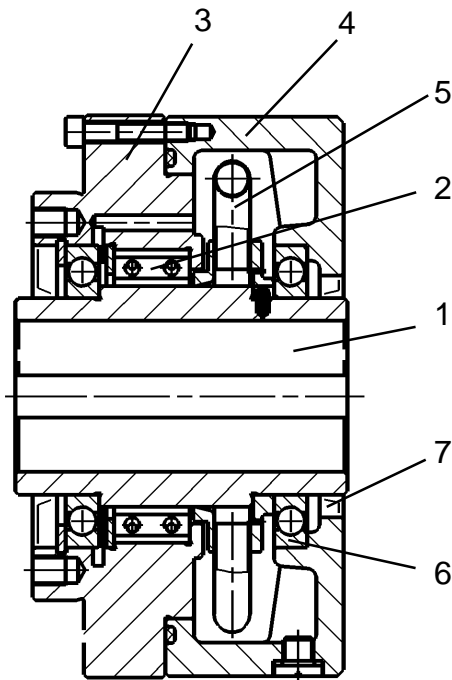

Fig. [1]

Complete Freewheels FK_h are designed as shown in Fig. [1]. The essential functional components are the inner ring (1), the sprags (2), the outer ring (3), the oil chamber (4) the pitot tube (5), the bearings (6), the seals (7) and the lubricant.

4. Types

Complete Freewheels FK_h are designed for extended service life using sprag lift-off at high speed rotating outer ring.

Hydrodynamic sprag lift-off is the ideal solution for overrunning clutches at high speeds, not only in the freewheeling operation, but also in the driving operation, as can occur, for example, in multimotor drives. In the case of the hydrodynamic sprag lift-off, the lifting force is generated by an oil flow. The relative speed between the inner and outer rings is decisive for the lifting-off function. In this case, the driving speed can be just as high as the freewheeling speed.



Please note!

Further information especially on design, function and selection, permissible torques as well the lifting speeds and maximum drive speeds of these freewheels is provided in RINGSPANN Catalog 84 "Freewheels". Please contact RINGSPANN GmbH if you need assistance.

5. General instruction



Caution!

Reliable torque transmission between the freewheel is guaranteed only if the maximum permissible speed in driving operation of the freewheel is not exceeded.

Operation at speeds in excess of the speeds permitted for the different operating modes can result in damage and overheating of the freewheel!



Caution!

The maximum permissible freewheel torque must not be exceeded due to torque peaks in specific applications.

The maximum freewheel torque should be calculated according to RINGSPANN Catalog 84. Please consult with RINGSPANN if you need assistance.

Freewheel damage resulting by excessive torque peaks impair component function and can result in excessive overheating of the freewheel!



Caution!

If the system is exposed to axial and/or radial loads, the roller bearings in the freewheel should be checked with reference to the rules for calculation provided by the bearing manufacturer. It is essential to ensure that bearings will not be damaged.

Bearing damage can result in overheating and the impairment of freewheel function!



Caution!

Torsion vibrations (amplitudes and frequencies which result in engagement and release of the freewheel in rapid succession) must be avoided.

Torsion vibrations can result in overheating and the impairment of freewheel function!

RINGSPANN	Installation and Operating Instruction for Complete Freewheels FK_h			E 08.602 e	
Issue: 08.07.2011	version : 04	drawn.: Su	checked.: Ei	pages: 10	page: 6



Caution!

Seals must be correctly installed during the entire service life of the freewheel and must not be excessively worn.
Seals should be replaced as needed.

Seal damage can result in overheating and the impairment of freewheel function!

6. Condition at delivery

The freewheels are delivered oil-filled and ready for installation. They are packed in anti-corrosion paper.

7. Technical requirements for safe operation

The bore in the inner ring normally has a tolerance of ISO H7. The correct shaft tolerance is then ISO h6 or j6.

The key must have back play and may have only minimal width oversize, as otherwise the inner ring may be deformed.

The tolerance for the pilot diameter of the attachment part must be ISO H7 or J7.

8. Installation

The direction of machine or system rotation must be determined prior to freewheel installation.

Mark this direction with an arrow on the shaft to which the inner ring of the freewheel is to be mounted.

Ensure that the freewheeling direction of the freewheel matches the direction marked on the shaft.

Apply only uniformly distributed pressure (without heating) to the front face of the inner ring when mounting the freewheel to the shaft.

Secure the axial position of the freewheel inner ring on the shaft.

If the freewheel is mounted with its outer ring on the centering device of the customer, this operation must be performed by applying uniform pressure to the front face of the outer ring around the entire circumference.



Caution!

The freewheel may not be driven onto the shaft by applying hammer blows, as the built-in roller bearings may be damaged in the process!

For the fastening screws a material quality of 8.8 is sufficient. Tightening torques are to be selected in accordance with VDI 2230 on the basis of the existing friction values in a given case.



Caution!

Screws with material grade 12.9 should not be used because of their low breaking elongation.

9. Inspection prior to commissioning

The oil level must be checked prior to initial operation of the freewheel. (see Fig. [2])

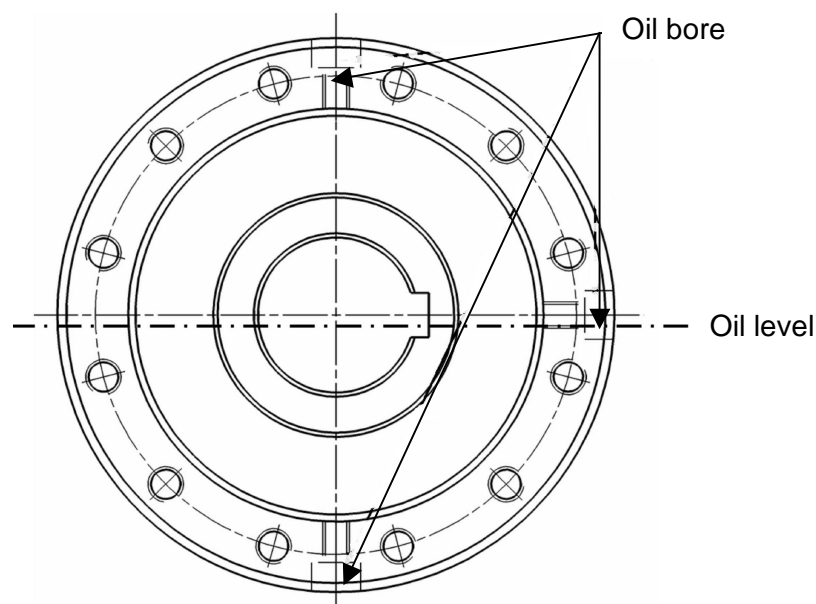

Fig. [2]

Three oil bores on the circumference of the freewheel are provided for this purpose.

- Turn the outer ring of the freewheel until the two opposite oil bores are positioned vertically, one above the other. This aligns three oil bores along the middle of the shaft.
- Remove the screws and gaskets from the side and upper oil bores
- Pour oil into one of the oil bores until it runs out of the opposite bore. See the oil selection table in Section 11 "Lubricants" for the appropriate grade of oil.
- Close the two oil bores with the gaskets and screws.
- Turn the freewheel-outer ring against to the freewheel-inner ring by hand in the freewheeling direction (freewheeling operation). If the freewheel turns roughly, apply a light hammer blow to the outer ring while turning the freewheel by hand in the freewheeling direction.



Caution!

A certain degree of friction is caused by the seals. This is reduced after a short operating time.

RINGSPANN	Installation and Operating Instruction for Complete Freewheels FK_h			E 08.602 e	
Issue: 08.07.2011	version : 04	drawn.: Su	checked.: Ei	pages: 10	page: 8

10. Maintenance



Caution!

The first oil change must be performed after 20 hours of operation!

During the first oil change, all particles accumulated during the “running in” procedure should be removed from the freewheel. That is why this oil change is required to ensure the service life of the freewheel.

Subsequent oil changes must be performed after every 2,000 operating hours, at a minimum



Information!

If oil is changed at longer intervals, we recommend using the synthetic lubricant MOBIL SHC 626.

If this lubricant is used, it must be changed after every 4,000 operating hours.

When the speed difference between the inner and outer ring will be less than 100 min^{-1} longer oil change intervals are allowed after consultation.

Oil change procedure:

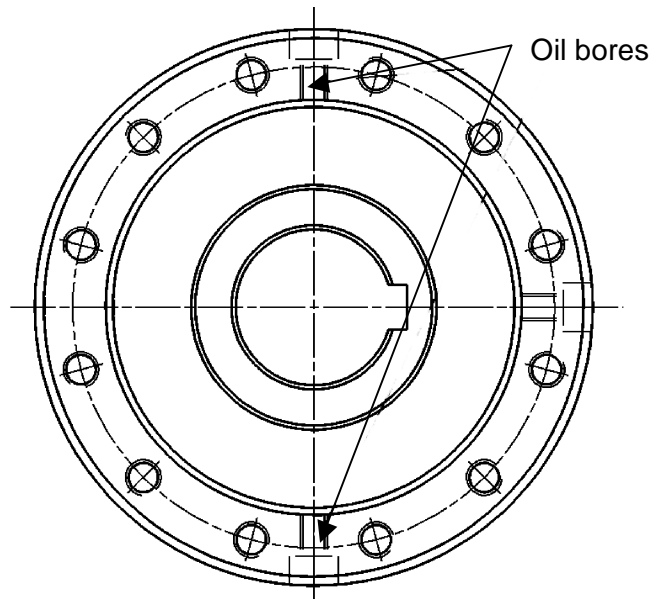

Fig. [3]

- Turn the freewheel until the two of the three oil bores are positioned one above the other (see Fig. [3]).
- Remove the screws and gaskets from all three oil bores.
- Collect and dispose of the old oil in accordance with applicable regulations.
- Clean the freewheel with cleaning oil and dispose of the cleaning oil in accordance with applicable regulations.
- Close the lower oil bore with a gasket and screw.
- Pour oil into one of the oil bores until it runs out of the opposite bore. See the oil selection table in Section 11 "Lubricants" for the appropriate grade of oil.
- Close the two oil bores with the gaskets and screws.



Caution!

If seal problems occur (leakage) during operation, the machine or system must be shut down immediately. Determine the cause of the leak and replace the freewheel if necessary!

11. Lubricants

The freewheels are delivered oil-filled. Please follow the instructions in Section 9 before commissioning. We recommend the following grades of oil for lubrication or oil changes:

Oil table			
Ambient temperature	For ambient temperatures from 0 °C to 50 °C	For ambient temperatures from –15 °C to +15 °C	For ambient temperatures from – 40 °C to 0 °C
Kinematic viscosity at 40 °C, ISO-VG	46/68 [mm²/s]	32 [mm²/s]	10 [mm²/s]
AGIP	OSO 46/68	OSO 32	OSO 10
ARAL	VITAM GF 46/68	VITAM GF 32	VITAM GF 10
BP	ENERGOL HLP 46/68	ENERGOL HLP 32	AERO HYDRAULIC 1
CASTROL	VARIO HDX	VARIO HDX	ALPHASYNTH 15
CHEVRON	EP HYDRAULIC OIL 46/68	EP HYDRAULIC OIL 32	HYJET IV
DEA	ASTRON HLP 46	ASTRON HLP 32	ASTRON HLP 10
ELF	ELFOLNA 46	ELFOLNA 32	ELF AVIATION HYDRAULIC OIL 20
ESSO	NUTO H 46/68	NUTO H 32	UNIVIS J 13
KLÜBER	LAMORA HLP 46/68	LAMORA HLP 32	Klüberoil 4 UH1-15
MOBIL	D.T.E. 25/26	D.T.E. 24	AERO HF A
SHELL	TELLUS OIL 46/68	TELLUS OIL 32	TELLUS OIL 10
Other manufacturers	Gearbox- or hydraulic oils without solid lubricants ISO-VG 46/68	Gearbox- or hydraulic oils without solid lubricants ISO-VG 32; Automatic transmission fluids [ATF]	Gearbox- or hydraulic oils without solid lubricants ISO-VG 10; Note setting point! Aviation hydraulic oils ISO-VG 10

Please contact us if temperatures exceed + 50 °C or fall below – 40 °C

	<p>Caution!</p> <p>Oils that contain friction-reducing additives like molybdenum disulfide or the like, may only be used with our authorisation.</p>
---	---