

APPLICATION APPLICAZIONE **K2,F5**

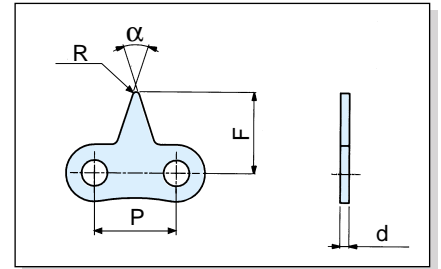

ISO N°	Regina Chain N° Codice Catena Regina	Pitch Passo		Roller Diameter Diametro Rullo	Inside Width Larghezza interna	Attachment N° Codice Attacco	Attachment on roller link Attacco sulla maglia interna	Attachment on pin link Attacco sulla maglia esterna	Materials Materiali	Attachment dimensions (mm) Dimensioni attacchi (mm)					Add. weight per attachment Peso aggiuntivo per attacco kg	Availability Disponibilità
		P	Dr							W	α	β	F	d		
		mm	" inches	mm	mm											
06B-1	C121	9,525	3/8	6,35	5,72	1023A	x	ss	30°	15°	9,90	1,030	-	0,0003	○	
083	54	12,70	1/2	7,75	4,88	155	x	cs,ss	36°	-	12,50	1,400	0,80	0,0005	○	
08B-1	126	12,70	1/2	8,51	7,75	150	x	cs	30°	10°	14,50	1,400	-	0,0003	●	
08B-1	126	12,70	1/2	8,51	7,75	1009	x	cs	36°	-	12,50	1,400	0,80	0,0002	●	
08B-1	126	12,70	1/2	8,51	7,75	1010	x	cs	30°	10°	21,50	1,400	-	0,001	●	
08A-1	A40	12,70	1/2	7,95	7,85	141	x	cs	30°	10°	14,50	1,530	-	0,0002	●	
12B-1	140	19,05	3/4	12,07	11,68	194	x	cs	60°	-	12,00	1,700	-	0,0005	●	

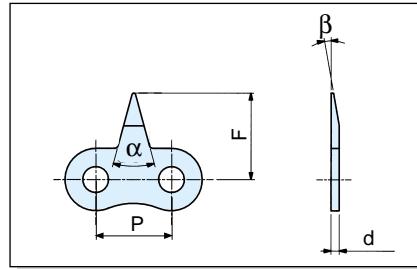
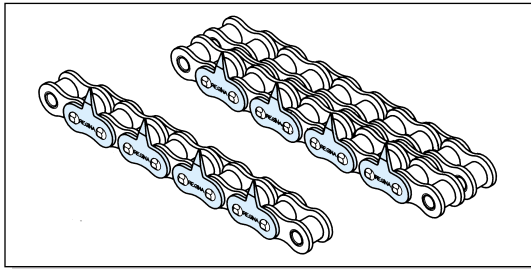
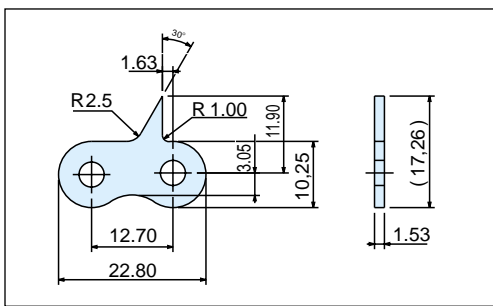

ISO N°	Regina Chain N° Codice Catena Regina	Pitch Passo		Attachment N° Codice Attacco	Attachment on roller link Attacco sulla maglia interna	Attachment on pin link Attacco sulla maglia esterna	Materials Materiali	Add. weight per attachment Peso aggiuntivo per attacco kg	Availability Disponibilità	Typical applications Applicazioni comuni
		P	Dr							
		mm	" inches							
08 A-1	A 40	12,70	1/2	167	x	cs	0,001	●	K2	

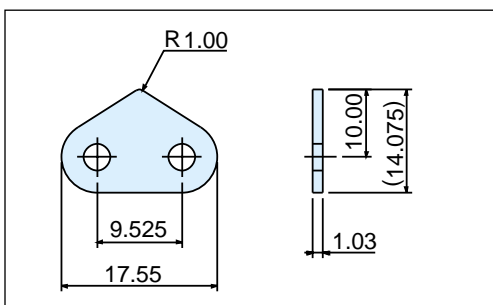

ISO N°	Regina Chain N° Codice Catena Regina	Pitch Passo		Attachment N° Codice Attacco	Attachment on roller link Attacco sulla maglia interna	Attachment on pin link Attacco sulla maglia esterna	Materials Materiali	Add. weight per attachment Peso aggiuntivo per attacco kg	Availability Disponibilità	Typical applications Applicazioni comuni
		P	Dr							
		mm	" inches							
06 B-1	C121	9,525	3/8	1020	x	cs	0,0003	○	H1	

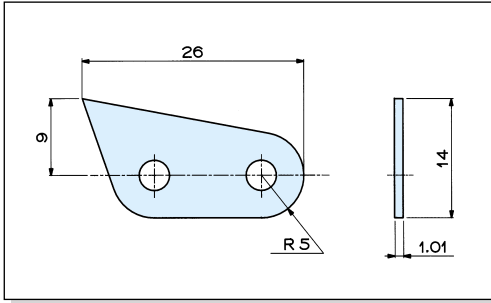

ISO N°	Regina Chain N° Codice Catena Regina	Pitch Passo		Attachment N° Codice Attacco	Attachment on roller link Attacco sulla maglia interna	Attachment on pin link Attacco sulla maglia esterna	Materials Materiali	Add. weight per attachment Peso aggiuntivo per attacco	Availability Disponibilità	
		mm	" inches							
082	50	12,70	1/2	144		x	cs	0,001	○	

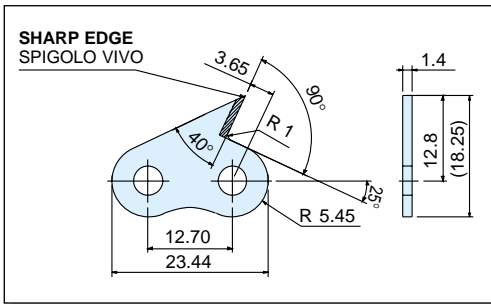

ISO N°	Regina Chain N° Codice Catena Regina	Pitch Passo		Attachment N° Codice Attacco	Attachment on roller link Attacco sulla maglia interna	Attachment on pin link Attacco sulla maglia esterna	Materials Materiali	Add. weight per attachment Peso aggiuntivo per attacco	Availability Disponibilità	Typical applications Applicazioni comuni
		mm	" inches							
08 B-1	126	12,70	1/2	1066		x	cs	0,001	○	C1

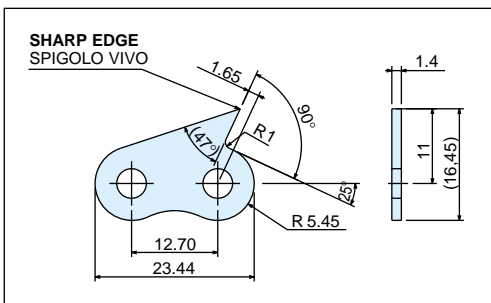

ISO N°	Regina Chain N° Codice Catena Regina	Pitch Passo		Attachment N° Codice Attacco	Attachment on roller link Attacco sulla maglia interna	Attachment on pin link Attacco sulla maglia esterna	Materials Materiali	Add. weight per attachment Peso aggiuntivo per attacco	Availability Disponibilità	Typical applications Applicazioni comuni
		mm	" inches							
08 B-1	126	12,70	1/2	1077		x	cs	0,0002	●	C1

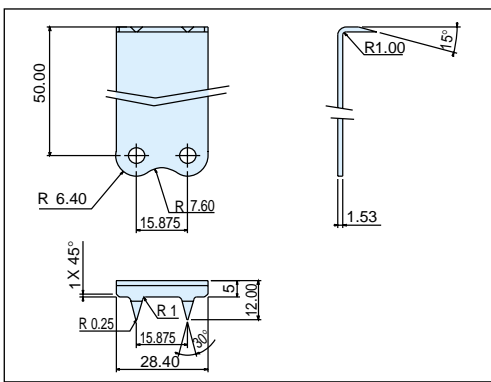

ISO N°	Regina Chain N° Codice Catena Regina	Pitch Passo		Attachment N° Codice Attacco	Attachment on roller link Attacco sulla maglia interna	Attachment on pin link Attacco sulla maglia esterna	Materials Materiali	Add. weight per attachment Peso aggiuntivo per attacco	Availability Disponibilità	Typical applications Applicazioni comuni
		mm	" inches							
10 B-1	136	15,875	5/8	154		§	cs	0,01	○	K2

§ Attachment on central plate
Attacco su piastra separatrice

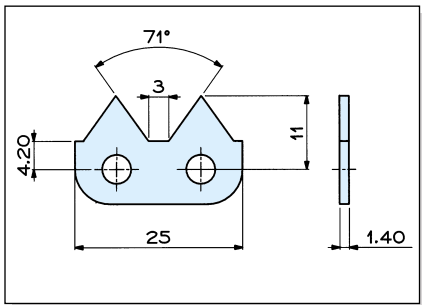
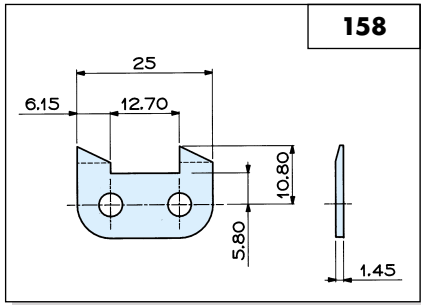
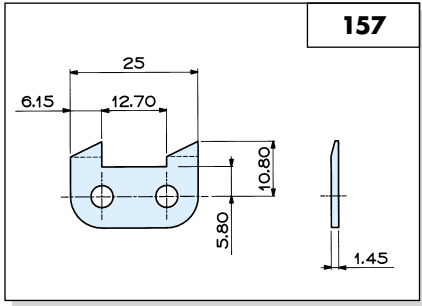
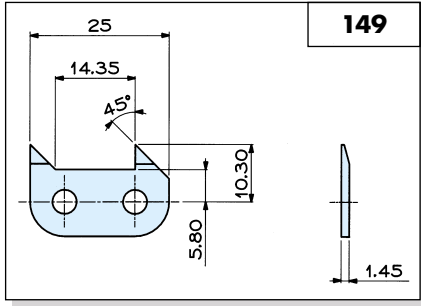
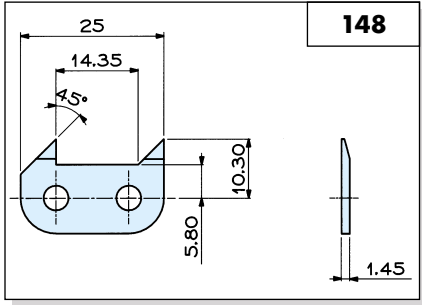

ISO N°	Regina Chain N° Codice Catena Regina	Pitch Passo		Attachment N° Codice Attacco	Attachment on roller link Attacco sulla maglia interna	Attachment on pin link Attacco sulla maglia esterna	Materials Materiali	Add. weight per attachment Peso aggiuntivo per attacco	Availability Disponibilità	Typical applications Applicazioni comuni
		mm	" inches							
08 B-1	126	12,70	1/2	148		x	cs	0,001	○	K2
08 B-1	126	12,70	1/2	149		x	cs	0,001	○	

ISO N°	Regina Chain N° Codice Catena Regina	Pitch Passo		Attachment N° Codice Attacco	Attachment on roller link Attacco sulla maglia interna	Attachment on pin link Attacco sulla maglia esterna	Materials Materiali	Add. weight per attachment Peso aggiuntivo per attacco	Availability Disponibilità	Typical applications Applicazioni comuni
		mm	" inches							
08 B-1	126	12,70	1/2	157		x	cs	0,002	○	K2
08 B-1	126	12,70	1/2	158		x	cs	0,002	○	

ISO N°	Regina Chain N° Codice Catena Regina	Pitch Passo		Attachment N° Codice Attacco	Attachment on roller link Attacco sulla maglia interna	Attachment on pin link Attacco sulla maglia esterna	Materials Materiali	Add. weight per attachment Peso aggiuntivo per attacco	Availability Disponibilità	Typical applications Applicazioni comuni
		mm	" inches							
08 B-1	126	12,70	1/2	182		x	cs,ss	0,001	●	C3

PUSHER ATTACHMENTS

ATTACCHI A SPINTORE

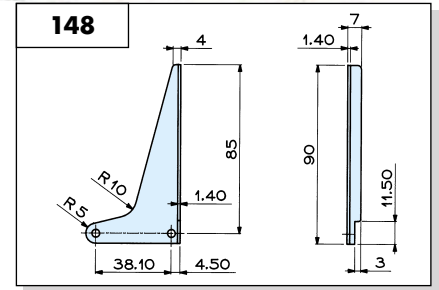
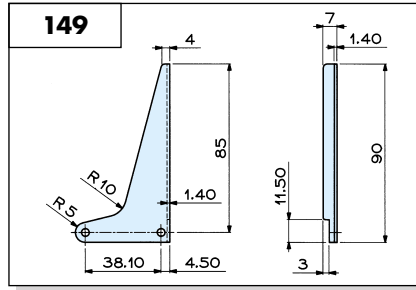
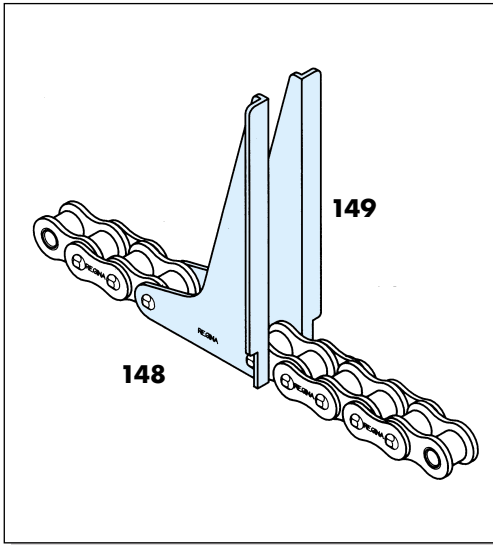

ISO N°	Regina Chain N° Codice Catena Regina	Pitch Passo		Attachment N° Codice Attacco	Attachment on roller link Attacco sulla maglia interna	Attachment on pin link Attacco sulla maglia esterna	Materials Materiali	Add. weight per attachment Peso aggiuntivo per attacco	Availability Disponibilità	Typical applications Applicazioni comuni
		P						kg		
		mm	" inches							
083	54	12,70	1/2	149		x	cs	0,016	○	K1
083	54	12,70	1/2	148		x	cs	0,016	○	

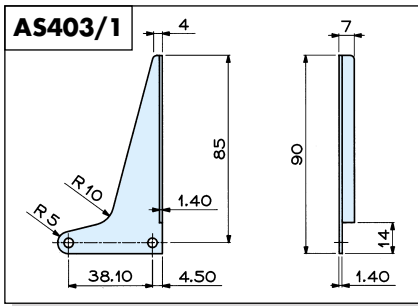
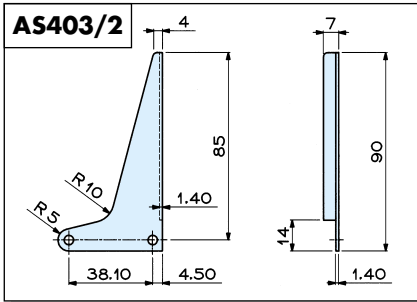

ISO N°	Regina Chain N° Codice Catena Regina	Pitch Passo		Attachment N° Codice Attacco	Attachment on roller link Attacco sulla maglia interna	Attachment on pin link Attacco sulla maglia esterna	Materials Materiali	Add. weight per attachment Peso aggiuntivo per attacco	Availability Disponibilità	Typical applications Applicazioni comuni
		P						kg		
		mm	" inches							
08 B-1	126	12,70	1/2	AS403/2		x	cs	0,03	○	K1
08 B-1	126	12,70	1/2	AS403/1		x	cs	0,03	○	

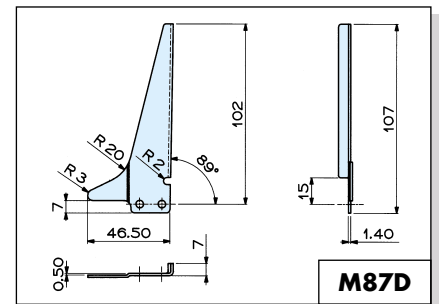
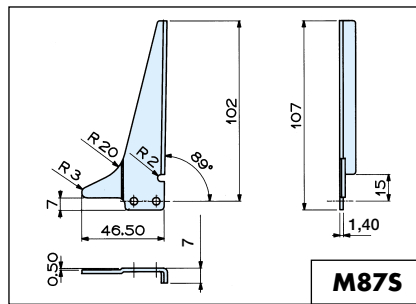
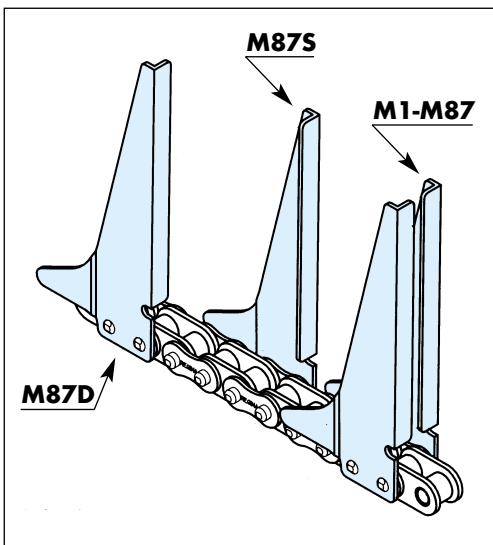

ISO N°	Regina Chain N° Codice Catena Regina	Pitch Passo		Attachment N° Codice Attacco	Attachment on roller link Attacco sulla maglia interna	Attachment on pin link Attacco sulla maglia esterna	Materials Materiali	Add. weight per attachment Peso aggiuntivo per attacco	Availability Disponibilità	Typical applications Applicazioni comuni
		P						kg		
		mm	" inches							
08 B-1	8126	12,70	1/2	M1-M87		x	cs	0,05	●	K1
08 B-1	8126	12,70	1/2	M87D		x	cs	0,034	●	

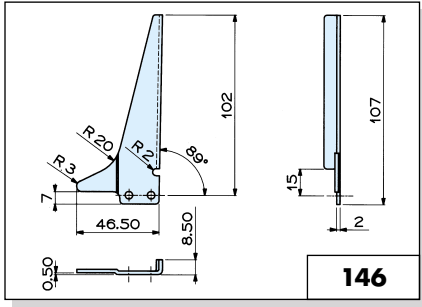

146

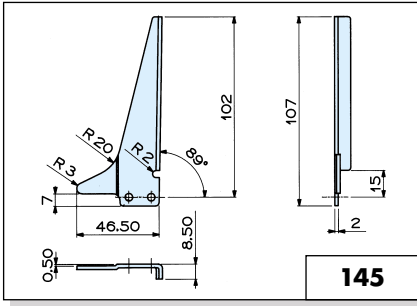

145

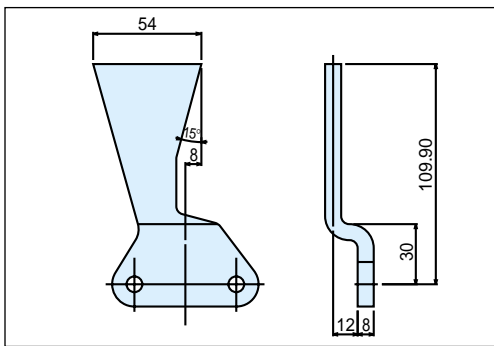
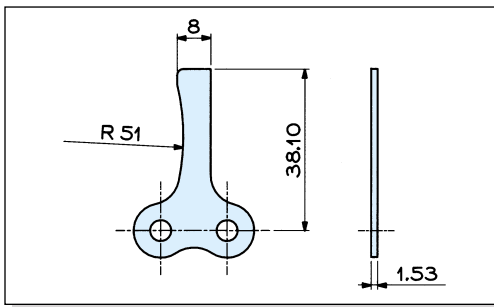
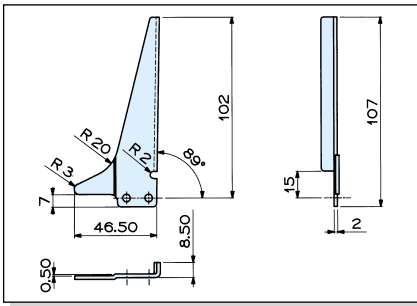

ISO N°	Regina Chain N° Codice Catena Regina	Pitch Passo		Attachment N° Codice Attacco	Attachment on roller link Attacco sulla maglia interna	Attachment on pin link Attacco sulla maglia esterna	Materials Materiali	Add. weight per attachment Peso aggiuntivo per attacco	Availability Disponibilità	Typical applications Applicazioni comuni
		mm	" inches							
08 B-1	8126	12,70	1/2	146		x	cs	0,038	●	K1
08 B-1	8126	12,70	1/2	145		x	cs	0,038	●	

ISO N°	Regina Chain N° Codice Catena Regina	Pitch Passo		Attachment N° Codice Attacco	Attachment on roller link Attacco sulla maglia interna	Attachment on pin link Attacco sulla maglia esterna	Materials Materiali	Add. weight per attachment Peso aggiuntivo per attacco	Availability Disponibilità	Typical applications Applicazioni comuni
		mm	" inches							
08 B-1	8126	12,70	1/2	151		x	cs	0,038	●	K1

ISO N°	Regina Chain N° Codice Catena Regina	Pitch Passo		Attachment N° Codice Attacco	Attachment on roller link Attacco sulla maglia interna	Attachment on pin link Attacco sulla maglia esterna	Materials Materiali	Add. weight per attachment Peso aggiuntivo per attacco	Availability Disponibilità	Typical applications Applicazioni comuni
		mm	" inches							
10 B-1	136	15,875	5/8	160		x	cs	0,003	●	

ISO N°	Regina Chain N° Codice Catena Regina	Pitch Passo		Attachment N° Codice Attacco	Attachment on roller link Attacco sulla maglia interna	Attachment on pin link Attacco sulla maglia esterna	Materials Materiali	Add. weight per attachment Peso aggiuntivo per attacco	Availability Disponibilità	Typical applications Applicazioni comuni
		mm	" inches							
C216A-H	C2080H	50,80	2	159		x	cs	0,3	○	

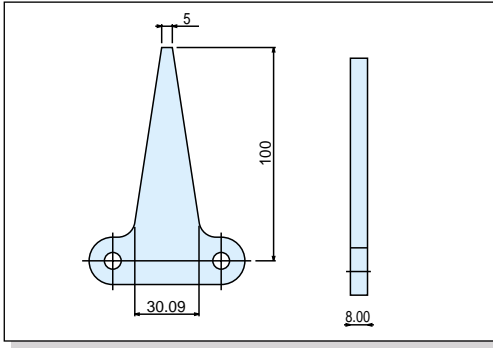

ISO N°	Regina Chain N° Codice Catena Regina	Pitch Passo		Attachment N° Codice Attacco	Attachment on roller link Attacco sulla maglia interna	Attachment on pin link Attacco sulla maglia esterna	Materials Materiali	Add. weight per attachment Peso aggiuntivo per attacco	Availability Disponibilità
		mm	" inches						
C216A-H	C2080H	50,80	2	158		x	cs	0,15	○

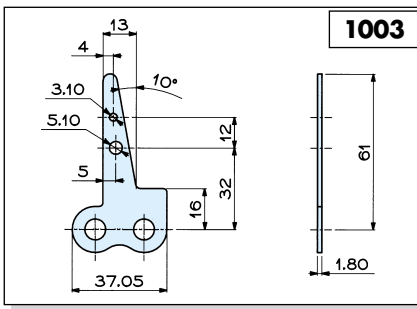

ISO N°	Regina Chain N° Codice Catena Regina	Pitch Passo		Attachment N° Codice Attacco	Attachment on roller link Attacco sulla maglia interna	Attachment on pin link Attacco sulla maglia esterna	Materials Materiali	Add. weight per attachment Peso aggiuntivo per attacco	Availability Disponibilità	Typical applications Applicazioni comuni
		mm	" inches							
12 B-1	140	19,05	3/4	1003		x	cs	0,01	●	G1
12 B-1	140	19,05	3/4	1004		x	cs	0,01	●	

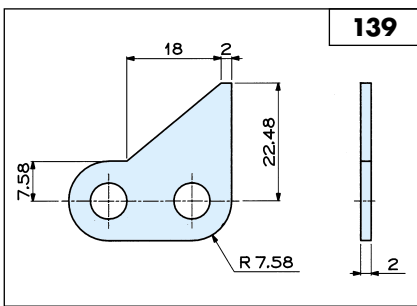
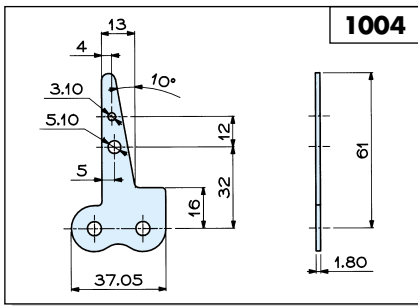

ISO N°	Regina Chain N° Codice Catena Regina	Pitch Passo		Attachment N° Codice Attacco	Attachment on roller link Attacco sulla maglia interna	Attachment on pin link Attacco sulla maglia esterna	Materials Materiali	Add. weight per attachment Peso aggiuntivo per attacco	Availability Disponibilità
		mm	" inches						
10 A-1	A 50	15,875	5/8	139		x	cs	0,004	●
10 A-1	A 50	15,875	5/8	140		x	cs	0,005	●

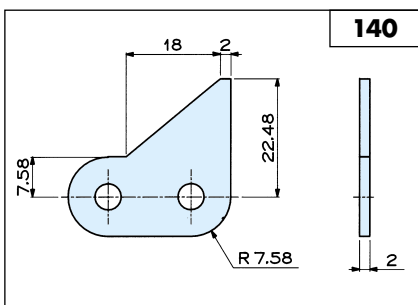

TRAPEZOID SHAPED ATTACHMENTS

ATTACCHI A TRAPEZIO

APPLICATION
APPLICAZIONE **G4,N1**

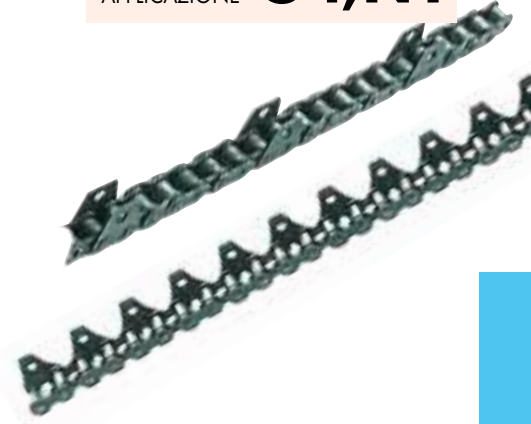
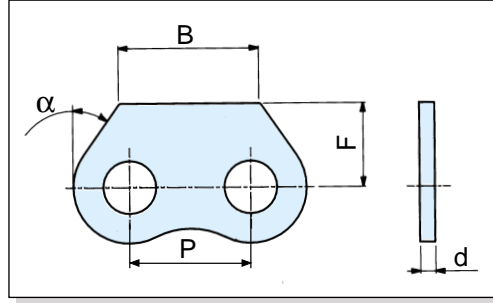
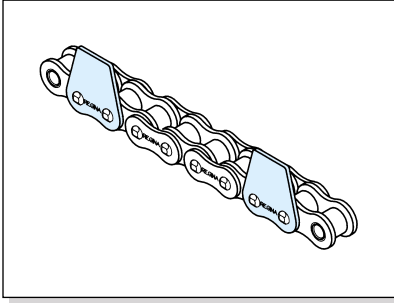

ISO N°	Regina Chain N° Codice Catena Regina	Pitch Passo		Roller Diameter Diametro Rullo	Inside Width Larghezza interna	Attachment N° Codice Attacco	Attachment on roller link Attacco sulla maglia interna	Attachment on pin link Attacco sulla maglia esterna	Materials Materiali	Attachment dimensions (mm) Dimensioni attacchi (mm)				Add. weight per attachment Peso aggiuntivo per attacco	Availability Disponibilità
		mm	" inches							α	B mm	d mm	F mm		
08 B-1	126	12,70	1/2	8,51	7,75	167	x		cs	60°	13,70	1,63	11,30	0,001	●
10 B-1	136	15,875	5/8	10,16	9,65	173A		x	ss		13,50	1,53	30,00	0,005	●
10 B-1	136	15,875	5/8	10,16	9,65	177A		x	ss		20,00	1,53	17,50	0,003	●
10 A-1	A 50	15,875	5/8	10,16	9,40	159	x		cs	70°	18,40	2,00	11,00	0,002	●
12 A-1	A 60	19,05	3/4	11,91	12,57	171	x		cs	90°	19,05	2,30	12,00	0,007	○
40 B-1	175	63,50	2 1/2	39,37	38,10	146	x		cs		60,00	8,00	50,00	0,19	○

Typical applications

Applicazioni comuni

N1

chain 175 with attachments

catena 175 con attacchi

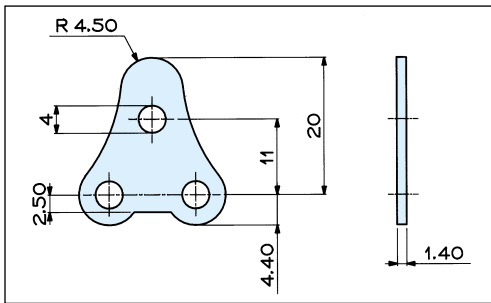

ISO N°	Regina Chain N° Codice Catena Regina	Pitch Passo		Attachment N° Codice Attacco	Attachment on roller link Attacco sulla maglia interna	Attachment on pin link Attacco sulla maglia esterna	Materials Materiali	Add. weight per attachment Peso aggiuntivo per attacco	Availability Disponibilità
		mm	" inches						
083	54	12,70	1/2	156		x	cs	0,002	●

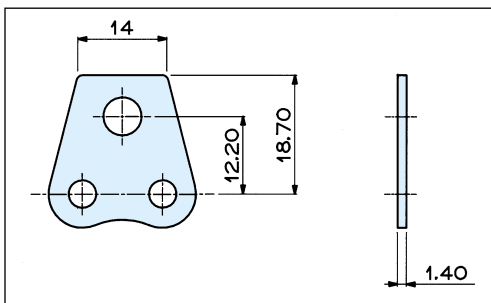

ISO N°	Regina Chain N° Codice Catena Regina	Pitch Passo		Attachment N° Codice Attacco	Attachment on roller link Attacco sulla maglia interna	Attachment on pin link Attacco sulla maglia esterna	Materials Materiali	Add. weight per attachment Peso aggiuntivo per attacco	Availability Disponibilità
		mm	" inches						
08 B-1	126	12,70	1/2	163		x	cs	0,002	●

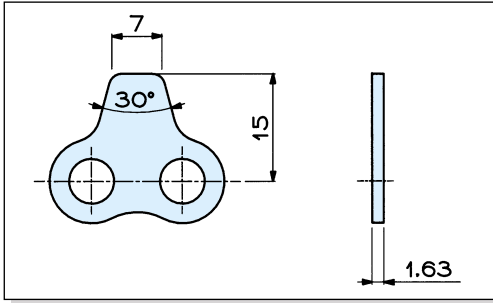

ISO N°	Regina Chain N° Codice Catena Regina	Pitch Passo		Attachment N° Codice Attacco	Attachment on roller link Attacco sulla maglia interna	Attachment on pin link Attacco sulla maglia esterna	Materials Materiali	Add. weight per attachment Peso aggiuntivo per attacco	Availability Disponibilità
		mm	" inches						
08 B-1	126	12,70	1/2	197	x		cs	0,001	●

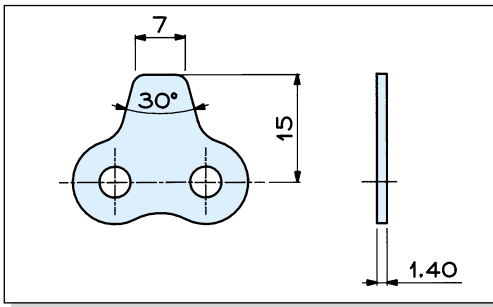

ISO N°	Regina Chain N° Codice Catena Regina	Pitch Passo		Attachment N° Codice Attacco	Attachment on roller link Attacco sulla maglia interna	Attachment on pin link Attacco sulla maglia esterna	Materials Materiali	Add. weight per attachment Peso aggiuntivo per attacco	Availability Disponibilità
		mm	" inches						
08 B-1	126	12,70	1/2	1006		x	cs	0,001	●

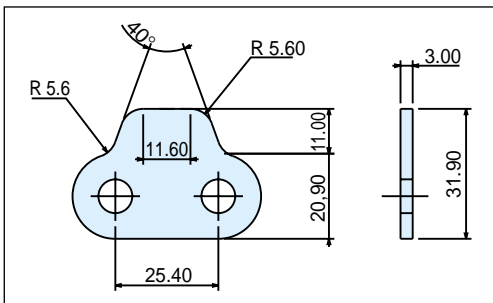

ISO N°	Regina Chain N° Codice Catena Regina	Pitch Passo		Attachment N° Codice Attacco	Attachment on roller link Attacco sulla maglia interna	Attachment on pin link Attacco sulla maglia esterna	Materials Materiali	Add. weight per attachment Peso aggiuntivo per attacco	Availability Disponibilità
		mm	" inches						
16 B-1	147	25,40	1	1000A		x	ss	0,006	○

TOWER SHAPED ATTACHMENTS

ATTACCHI A TORRE

APPLICATION
APPLICAZIONE **G,F1**

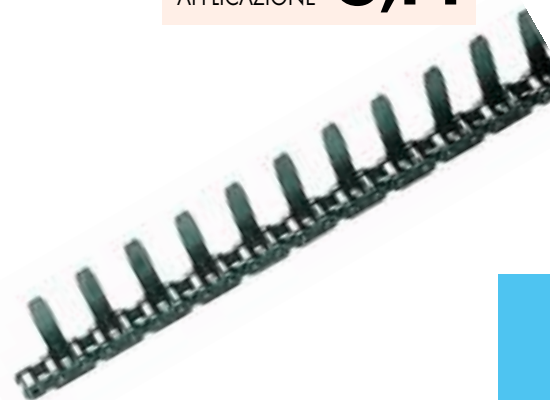
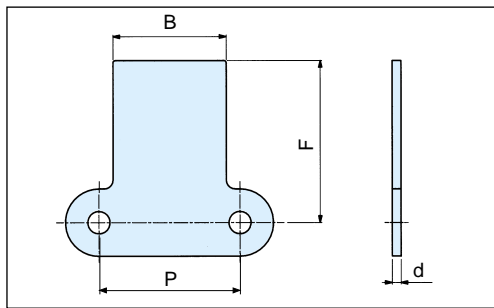
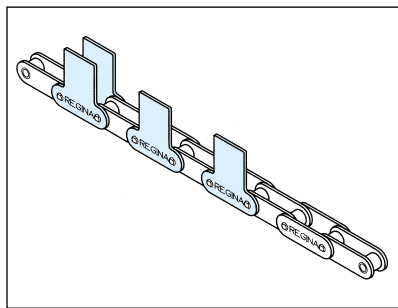

ISO N°	Regina Chain N° Codice Catena Regina	Pitch Passo		Roller Diameter Diametro Rullo	Inside Width Larghezza interna	Attachment N° Codice Attacco	Attachment on roller link Attacco sulla maglia interna	Attachment on pin link Attacco sulla maglia esterna	Materials Materiali	Attachment dimensions (mm) Dimensioni attacchi (mm)			Add. weight per attachment Peso aggiuntivo per attacco	Availability Disponibilità
		mm	P " inches							B mm	d mm	F mm		
083	54	12,70	1/2	7,75	4,88	147		x	cs	9,50	1,40	17,10	0,001	●
08 B-1	126	12,70	1/2	8,51	7,75	123		x	cs	9,50	1,40	19,20	0,001	●
08 B-1	126	12,70	1/2	8,51	7,75	189		x	cs	23,06	1,40	25,75	0,004	●
08 B-1	126	12,70	1/2	8,51	7,75	190A	x		ss	24,50	1,63	18,70	0,005	○
10 B-1	136	15,875	5/8	10,16	9,65	155		x	cs	29,80	1,53	17,00	0,004	●
10 B-1	136	15,875	5/8	10,16	9,65	157		x	cs	28,60	1,53	23,70	0,007	●
10 B-1	136	15,875	5/8	10,16	9,65	149A	x		ss	30,00	1,63	23,70	0,008	●
10 B-1	136	15,875	5/8	10,16	9,65	164A	x		ss	14,10	1,63	23,70	0,006	○
10 B-1	136	15,875	5/8	10,16	9,65	176A	x		ss	30,00	1,63	17,50	0,005	○
10 A-1	A 50	15,875	5/8	10,16	9,40	142		x	cs	14,10	2,00	23,70	0,004	●
10 A-1	A 50	15,875	5/8	10,16	9,40	155		x	cs	20,00	2,00	45,00	0,012	●
10 A-1	A 50	15,875	5/8	10,16	9,40	161		x	cs	20,00	2,00	80,00	0,023	●
12 A-1	A 60	19,05	3/4	11,91	12,57	150	x		cs	16,00	2,40	14,00	0,001	○
12 A-1	A 60	19,05	3/4	11,91	12,57	160		x	cs	16,00	2,40	26,20	0,006	●
12 A-1	A 60	19,05	3/4	11,91	12,57	164A		x	ss	15,86	2,30	32,50	0,008	●
208 B	2126	25,40	1	8,51	7,75	147		x	cs	19,05	1,40	49,75	0,009	○
C210AS	C2050	31,75	1 1/4	10,16	9,40	149		x	cs,ss	25,40	2,00	36,50	0,012	●
32 B-1	165	50,80	2	29,21	30,99	144	x		cs	60,00	7,00	57,50	0,16	○
32 B-1	165	50,80	2	29,21	30,99	145		x	cs	60,00	7,00	57,50	0,18	○

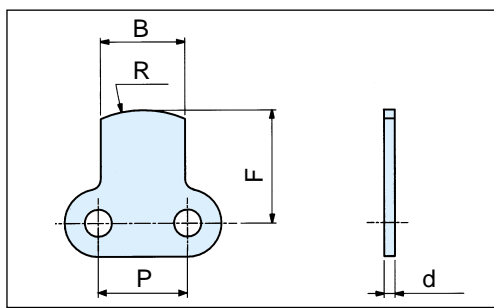
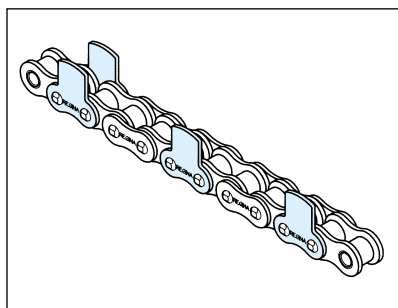

ISO N°	Regina Chain N° Codice Catena Regina	Pitch Passo		Roller Diameter Diametro Rullo	Inside Width Larghezza interna	Attachment N° Codice Attacco	Attachment on roller link Attacco sulla maglia interna	Attachment on pin link Attacco sulla maglia esterna	Materials Materiali	Attachment dimensions (mm) Dimensioni attacchi (mm)				Add. weight per attachment Peso aggiuntivo per attacco	Availability Disponibilità
		mm	P " inches							B mm	R mm	d mm	F mm		
083	54	12,70	1/2	7,75	4,88	154		x	cs,ss	12,00	15,00	1,40	16,00	0,002	○
08 B-1	126	12,70	1/2	8,51	7,75	183		x	cs,ss	9,50	4,00	1,40	43,00	0,004	●
08 A-1	A 40	12,70	1/2	7,92	7,85	160		x	cs	12,00	15,00	1,53	16,00	0,002	●

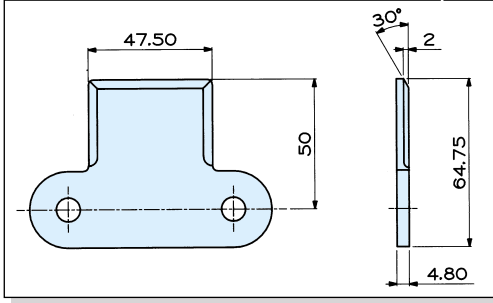

ISO N°	Regina Chain N° Codice Catena Regina	Pitch Passo		Attachment N° Codice Attacco	Attachment on roller link Attacco sulla maglia interna	Attachment on pin link Attacco sulla maglia esterna	Materials Materiali	Add. weight per attachment Peso aggiuntivo per attacco	Availability Disponibilità	
		mm	" inches							
C220A-H	C2100H	63,50	2 1/2	140		x	cs	0,063	○	

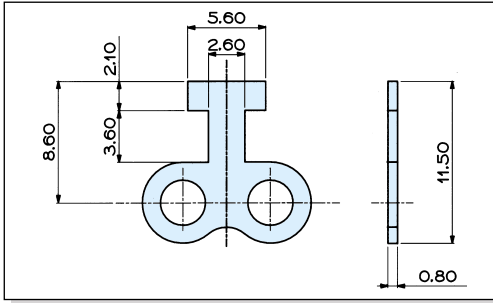

ISO N°	Regina Chain N° Codice Catena Regina	Pitch Passo		Attachment N° Codice Attacco	Attachment on roller link Attacco sulla maglia interna	Attachment on pin link Attacco sulla maglia esterna	Materials Materiali	Add. weight per attachment Peso aggiuntivo per attacco	Availability Disponibilità	Typical applications Applicazioni comuni
		mm	" inches							
04 C-1	A 25 [25L]	6,35	1/4	141	x		cs	0,0002	○	E1

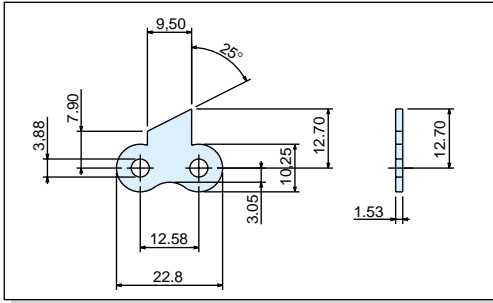

ISO N°	Regina Chain N° Codice Catena Regina	Pitch Passo		Attachment N° Codice Attacco	Attachment on roller link Attacco sulla maglia interna	Attachment on pin link Attacco sulla maglia esterna	Materials Materiali	Add. weight per attachment Peso aggiuntivo per attacco	Availability Disponibilità	Typical applications Applicazioni comuni
		mm	" inches							
08 A-1	A 40	12,70	1/2	163		x	cs	0,005	●	K4

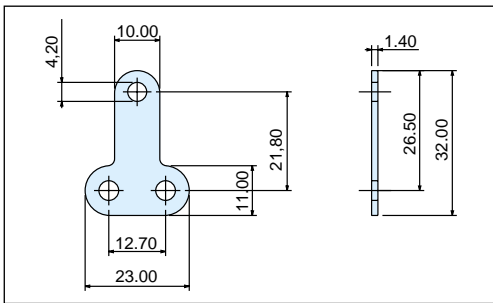

ISO N°	Regina Chain N° Codice Catena Regina	Pitch Passo		Attachment N° Codice Attacco	Attachment on roller link Attacco sulla maglia interna	Attachment on pin link Attacco sulla maglia esterna	Materials Materiali	Add. weight per attachment Peso aggiuntivo per attacco	Availability Disponibilità	Typical applications Applicazioni comuni
		mm	" inches							
08 B-1	126	12,70	1/2	145A		x	ss	0,003	○	K

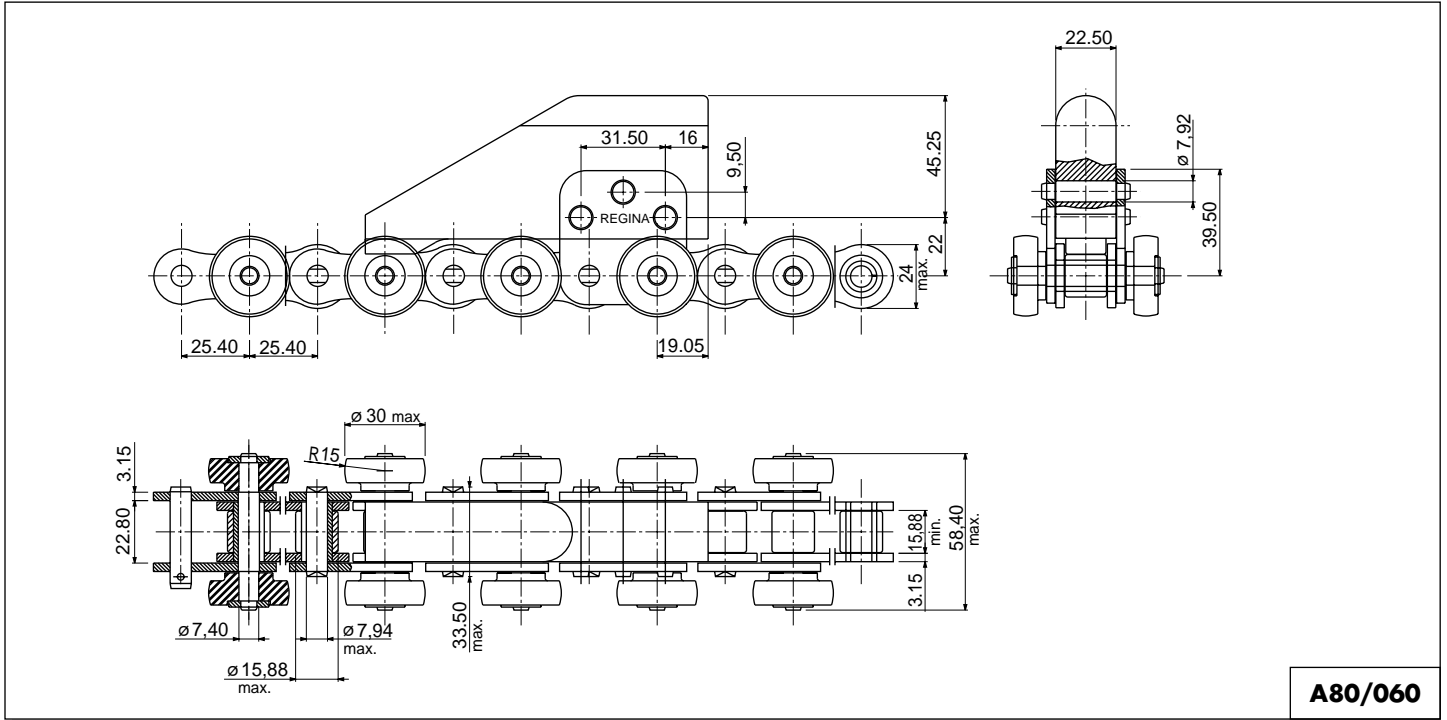

A80/060

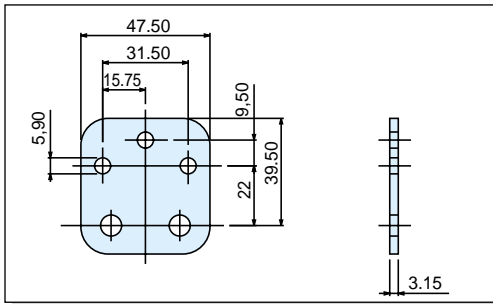

ISO N°	Regina Chain N° Codice Catena Regina	Pitch Passo		Attachment N° Codice Attacco	Attachment on roller link Attacco sulla maglia interna	Attachment on pin link Attacco sulla maglia esterna	Materials Materiali	Add. weight per attachment Peso aggiuntivo per attacco	Availability Disponibilità
		mm	" inches						
16 A-1	A 80	25,40	1	173		x	cs	0,036	○

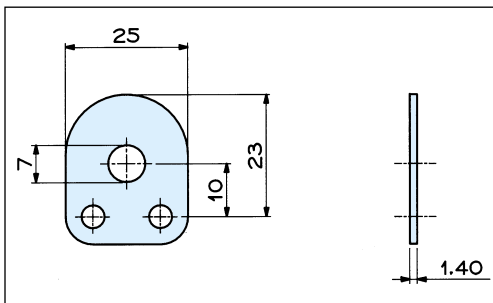

ISO N°	Regina Chain N° Codice Catena Regina	Pitch Passo		Attachment N° Codice Attacco	Attachment on roller link Attacco sulla maglia interna	Attachment on pin link Attacco sulla maglia esterna	Materials Materiali	Add. weight per attachment Peso aggiuntivo per attacco	Availability Disponibilità
		mm	" inches						
08 B-1	126	12,70	1/2	156		x	cs	0,004	○

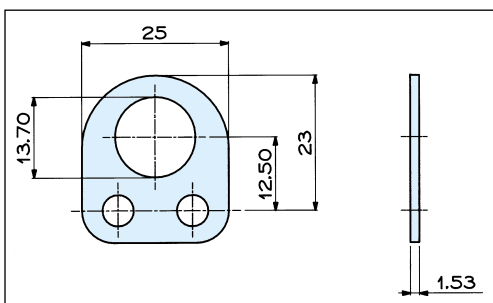

ISO N°	Regina Chain N° Codice Catena Regina	Pitch Passo		Attachment N° Codice Attacco	Attachment on roller link Attacco sulla maglia interna	Attachment on pin link Attacco sulla maglia esterna	Materials Materiali	Add. weight per attachment Peso aggiuntivo per attacco	Availability Disponibilità	Typical applications Applicazioni comuni
		mm	" inches							
08 A-1	A 40	12,70	1/2	136	x		cs	0,003	●	L4

"V" SHAPED ATTACHMENTS

ATTACCHI A "V"

APPLICATION
APPLICAZIONE **C3**

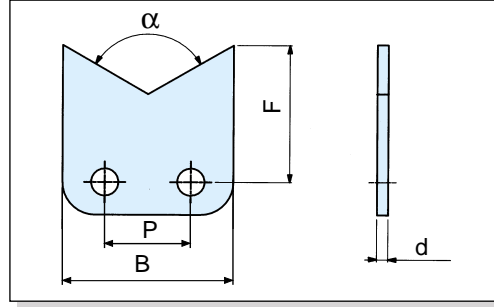
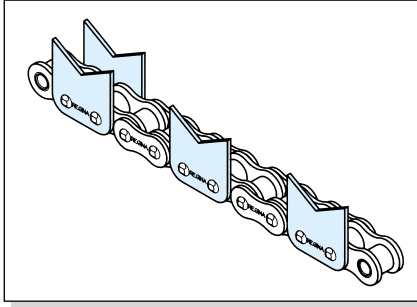

ISO N°	Regina Chain N° Codice Catena Regina	Pitch Passo		Roller Diameter Diametro Rullo	Inside Width Larghezza interna	Attachment N° Codice Attacco	Attachment on roller link Attacco sulla maglia interna	Attachment on pin link Attacco sulla maglia esterna	Materials Materiali	Attachment dimensions (mm) Dimensioni attacchi (mm)				Add. weight per attachment Peso aggiuntivo per attacco	Availability Disponibilità
		mm	" inches							alpha	B mm	d mm	F mm		
082	50	12,70	1/2	7,75	2,38	138		x	cs,ss	100°	24,90	1,01	15,00	0,002	●
082	50	12,70	1/2	7,75	2,38	139	x		cs	100°	24,90	1,01	15,00	0,002	●
082	50	12,70	1/2	7,75	2,38	141		x	cs	120°	24,90	1,01	20,00	0,003	●
083	54	12,70	1/2	7,75	4,88	139		x	cs,ss	100°	24,90	1,40	15,00	0,002	●
083	54	12,70	1/2	7,75	4,88	144		x	cs	90°	23,00	1,40	24,60	0,004	●
083	54	12,70	1/2	7,75	4,88	153		x	cs	120°	24,90	1,40	20,00	0,004	●
08 B-1	126	12,70	1/2	8,51	7,75	180		x	ss	100°	24,00	1,53	20,00	0,003	●
08 B-1	126	12,70	1/2	8,51	7,75	198		x	cs	100°	25,00	1,40	14,60	0,002	●
08 B-1	126	12,70	1/2	8,51	7,75	1027		x	cs	120°	25,00	1,40	20,00	0,003	●
084	90R	12,70	1/2	7,75	4,88	137		x	cs	120°	24,90	1,63	20,00	0,005	●
08 A-1	A 40	12,70	1/2	7,92	7,85	150		x	cs,ss	120°	24,90	1,53	20,00	0,004	●
08 A-1	A 40	12,70	1/2	7,92	7,85	157		x	cs	100°	25,00	1,53	14,60	0,002	●

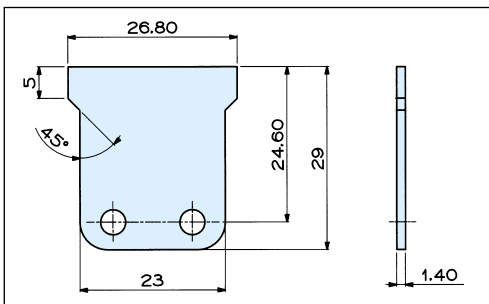

ISO N°	Regina Chain N° Codice Catena Regina	Pitch Passo		Attachment N° Codice Attacco	Attachment on roller link Attacco sulla maglia interna	Attachment on pin link Attacco sulla maglia esterna	Materials Materiali	Add. weight per attachment Peso aggiuntivo per attacco	Availability Disponibilità	Typical applications Applicazioni comuni
		mm	" inches							
083	54	12,70	1/2	143		x	cs	0,006	●	C3

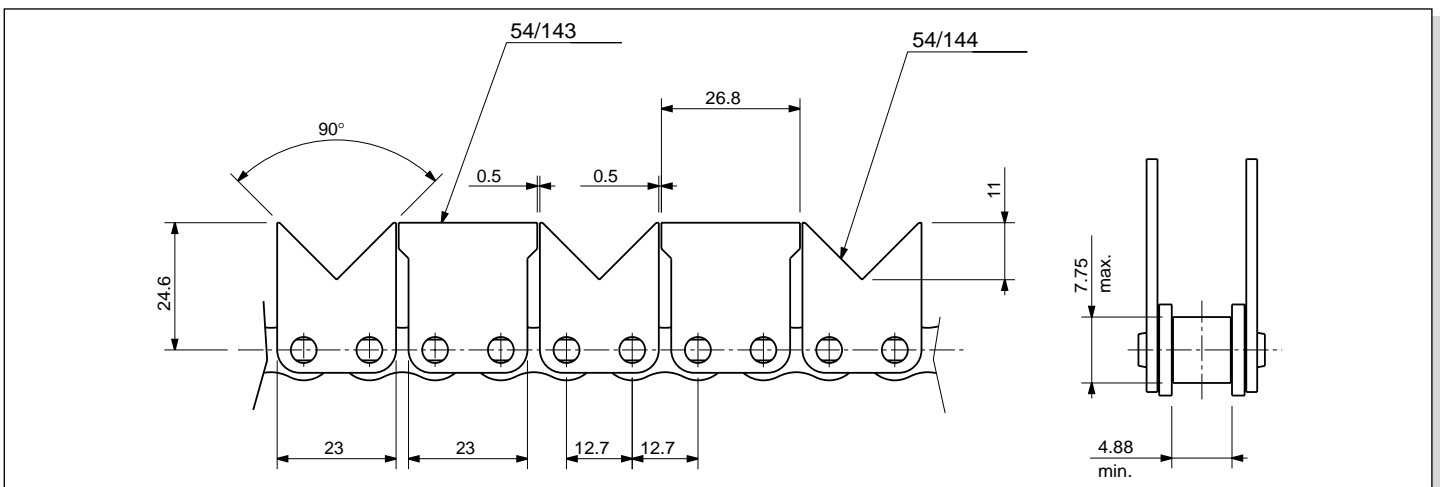

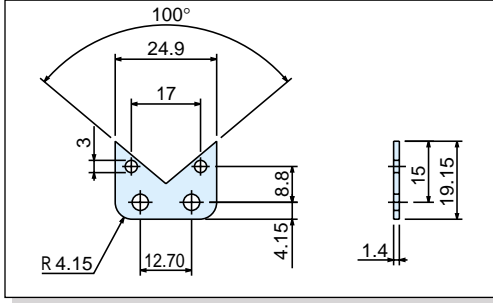

ISO N°	Regina Chain N° Codice Catena Regina	Pitch Passo		Attachment N° Codice Attacco	Attachment on roller link Attacco sulla maglia interna	Attachment on pin link Attacco sulla maglia esterna	Materials Materiali	Add. weight per attachment Peso aggiuntivo per attacco	Availability Disponibilità	Typical applications Applicazioni comuni
		mm	" inches							
083	54	12,70	1/2	163		x	cs,ss	0,002	●	L

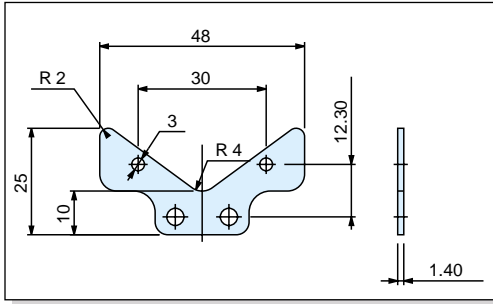

ISO N°	Regina Chain N° Codice Catena Regina	Pitch Passo		Attachment N° Codice Attacco	Attachment on roller link Attacco sulla maglia interna	Attachment on pin link Attacco sulla maglia esterna	Materials Materiali	Add. weight per attachment Peso aggiuntivo per attacco	Availability Disponibilità	Typical applications Applicazioni comuni
		mm	" inches							
083	54	12,70	1/2	161		x	cs	0,006	○	L

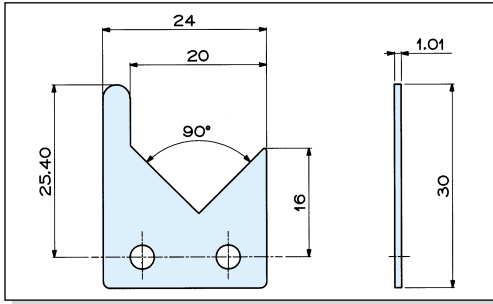

ISO N°	Regina Chain N° Codice Catena Regina	Pitch Passo		Attachment N° Codice Attacco	Attachment on roller link Attacco sulla maglia interna	Attachment on pin link Attacco sulla maglia esterna	Materials Materiali	Add. weight per attachment Peso aggiuntivo per attacco	Availability Disponibilità	Typical applications Applicazioni comuni
		mm	" inches							
082	50	12,70	1/2	140		x	cs	0,002	●	C3

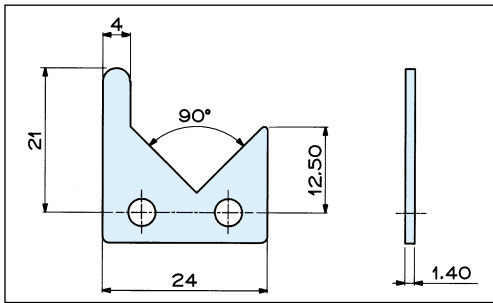

ISO N°	Regina Chain N° Codice Catena Regina	Pitch Passo		Attachment N° Codice Attacco	Attachment on roller link Attacco sulla maglia interna	Attachment on pin link Attacco sulla maglia esterna	Materials Materiali	Add. weight per attachment Peso aggiuntivo per attacco	Availability Disponibilità	Typical applications Applicazioni comuni
		mm	" inches							
083	54	12,70	1/2	158		x	cs	0,002	●	C3

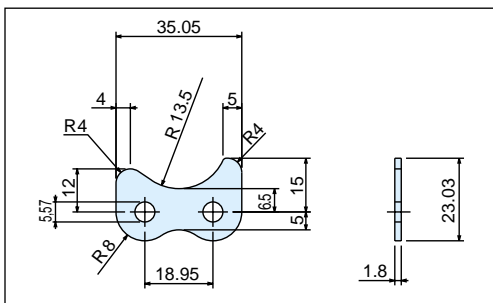

ISO N°	Regina Chain N° Codice Catena Regina	Pitch Passo		Attachment N° Codice Attacco	Attachment on roller link Attacco sulla maglia interna	Attachment on pin link Attacco sulla maglia esterna	Materials Materiali	Add. weight per attachment Peso aggiuntivo per attacco	Availability Disponibilità	Typical applications Applicazioni comuni
		mm	" inches							
12 B-1	140	19,05	3/4	180		x	cs	0,002	●	C3

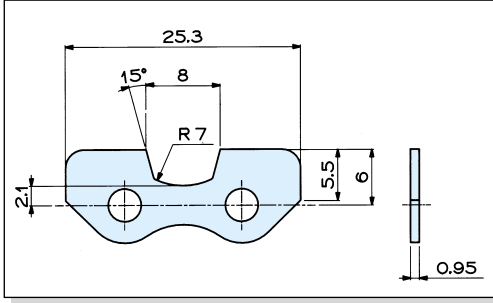

ISO N°	Regina Chain N° Codice Catena Regina	Pitch Passo		Attachment N° Codice Attacco	Attachment on roller link Attacco sulla maglia interna	Attachment on pin link Attacco sulla maglia esterna	Materials Materiali	Add. weight per attachment Peso aggiuntivo per attacco	Availability Disponibilità	Typical applications Applicazioni comuni
		mm	" inches							
082	50	12,70	1/2	136		x	cs	0,0005	●	J2

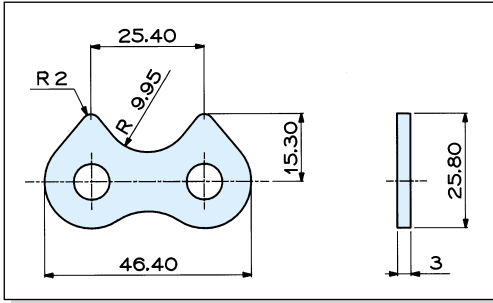

ISO N°	Regina Chain N° Codice Catena Regina	Pitch Passo		Attachment N° Codice Attacco	Attachment on roller link Attacco sulla maglia interna	Attachment on pin link Attacco sulla maglia esterna	Materials Materiali	Add. weight per attachment Peso aggiuntivo per attacco	Availability Disponibilità	Typical applications Applicazioni comuni
		mm	" inches							
16 B-1	147	25,40	1	137		x	cs,ss	0,004	●	F3

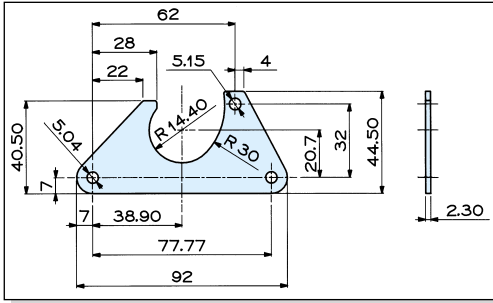

ISO N°	Regina Chain N° Codice Catena Regina	Pitch Passo		Attachment N° Codice Attacco	Attachment on roller link Attacco sulla maglia interna	Attachment on pin link Attacco sulla maglia esterna	Materials Materiali	Add. weight per attachment Peso aggiuntivo per attacco	Availability Disponibilità	Typical applications Applicazioni comuni
		mm	" inches							
C210AS	C2050	31,75	1 1/4	AS 450A		x	ss	0,016	○	F2

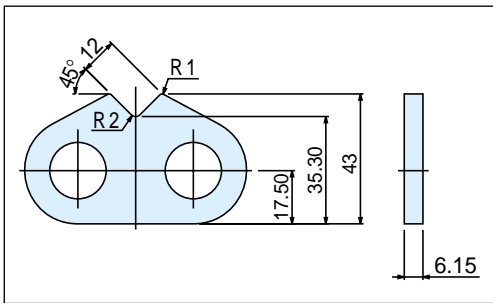

ISO N°	Regina Chain N° Codice Catena Regina	Pitch Passo		Attachment N° Codice Attacco	Attachment on roller link Attacco sulla maglia interna	Attachment on pin link Attacco sulla maglia esterna	Materials Materiali	Add. weight per attachment Peso aggiuntivo per attacco	Availability Disponibilità	Typical applications Applicazioni comuni
		mm	" inches							
24B-1	C157	38,10	1 1/2	136		x	cs	0,03	●	Q

SAW SHAPED ATTACHMENTS

ATTACCHI A SEGHETTO

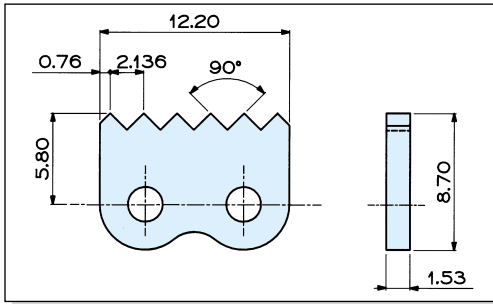

ISO N°	Regina Chain N° Codice Catena Regina	Pitch Passo		Attachment N° Codice Attacco	Attachment on roller link Attacco sulla maglia interna	Attachment on pin link Attacco sulla maglia esterna	Materials Materiali	Add. weight per attachment Peso aggiuntivo per attacco	Availability Disponibilità	Typical applications Applicazioni comuni
		mm	" inches							
04 C-1	A25 (25L)	6,35	1/4	142		x	cs	0,0008	●	P1

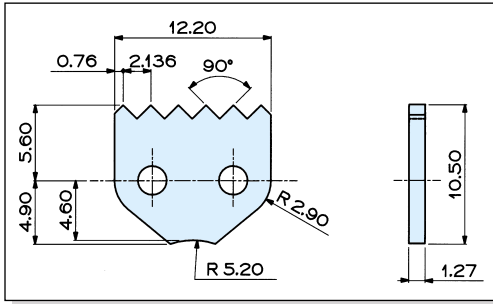

ISO N°	Regina Chain N° Codice Catena Regina	Pitch Passo		Attachment N° Codice Attacco	Attachment on roller link Attacco sulla maglia interna	Attachment on pin link Attacco sulla maglia esterna	Materials Materiali	Add. weight per attachment Peso aggiuntivo per attacco	Availability Disponibilità	Typical applications Applicazioni comuni
		mm	" inches							
04 C-1	A25 (25L)	6,35	1/4	143		x	cs	0,0007	●	P1

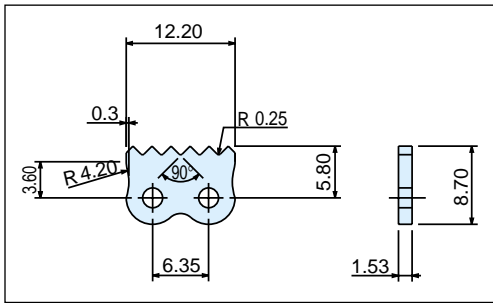

ISO N°	Regina Chain N° Codice Catena Regina	Pitch Passo		Attachment N° Codice Attacco	Attachment on roller link Attacco sulla maglia interna	Attachment on pin link Attacco sulla maglia esterna	Materials Materiali	Add. weight per attachment Peso aggiuntivo per attacco	Availability Disponibilità	Typical applications Applicazioni comuni
		mm	" inches							
04 C-1	A25 (25L)	6,35	1/4	144		x	cs	0,001	●	P1

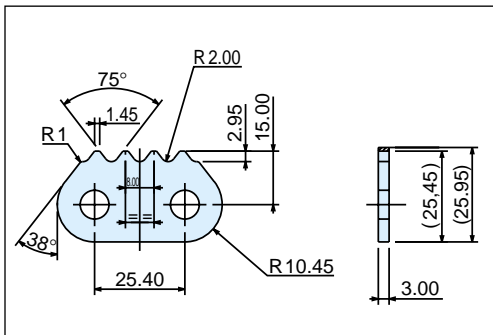

ISO N°	Regina Chain N° Codice Catena Regina	Pitch Passo		Attachment N° Codice Attacco	Attachment on roller link Attacco sulla maglia interna	Attachment on pin link Attacco sulla maglia esterna	Materials Materiali	Add. weight per attachment Peso aggiuntivo per attacco	Availability Disponibilità	Typical applications Applicazioni comuni
		mm	" inches							
16 B-1	147	25,40	1	1007		x	cs	0,004	○	Q2

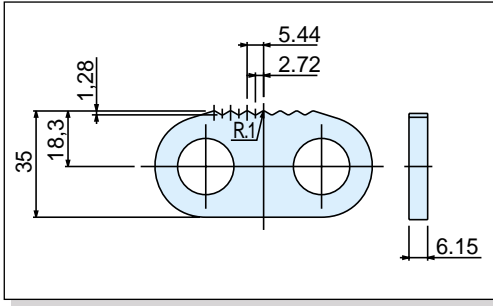

ISO N°	Regina Chain N° Codice Catena Regina	Pitch Passo		Attachment N° Codice Attacco	Attachment on roller link Attacco sulla maglia interna	Attachment on pin link Attacco sulla maglia esterna	Materials Materiali	Add. weight per attachment Peso aggiuntivo per attacco	Availability Disponibilità	Typical applications Applicazioni comuni
		mm	" inches							
24B-1	C157	38,10	1 1/2	148	x		cs	0,001	●	N1

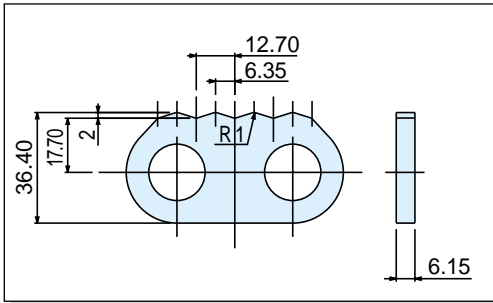

ISO N°	Regina Chain N° Codice Catena Regina	Pitch Passo		Attachment N° Codice Attacco	Attachment on roller link Attacco sulla maglia interna	Attachment on pin link Attacco sulla maglia esterna	Materials Materiali	Add. weight per attachment Peso aggiuntivo per attacco	Availability Disponibilità	Typical applications Applicazioni comuni
		mm	" inches							
24B-1	C157	38,10	1 1/2	145	x		cs	0,001	●	N1

WING SHAPED ATTACHMENTS

ATTACCHI AD ALA

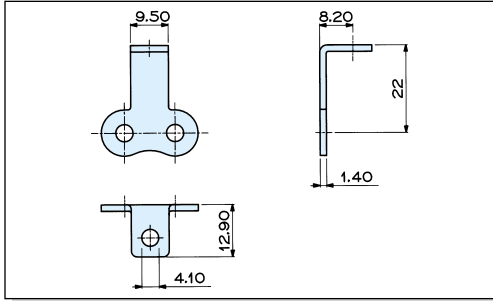

ISO N°	Regina Chain N° Codice Catena Regina	Pitch Passo		Attachment N° Codice Attacco	Attachment on roller link Attacco sulla maglia interna	Attachment on pin link Attacco sulla maglia esterna	Materials Materiali	Add. weight per attachment Peso aggiuntivo per attacco	Availability Disponibilità
		mm	" inches						
08 B-1	126	12,70	1/2	169		x	cs	0,003	○

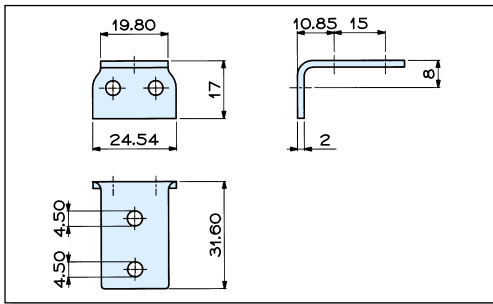

ISO N°	Regina Chain N° Codice Catena Regina	Pitch Passo		Attachment N° Codice Attacco	Attachment on roller link Attacco sulla maglia interna	Attachment on pin link Attacco sulla maglia esterna	Materials Materiali	Add. weight per attachment Peso aggiuntivo per attacco	Availability Disponibilità
		mm	" inches						
08 B-1	126	12,70	1/2	176		x	cs	0,012	●

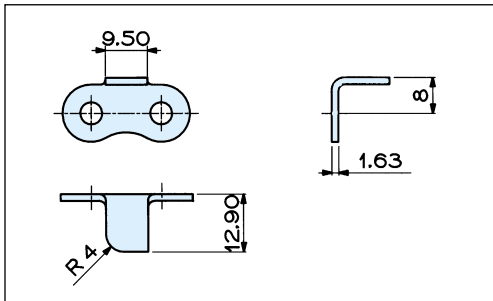

ISO N°	Regina Chain N° Codice Catena Regina	Pitch Passo		Attachment N° Codice Attacco	Attachment on roller link Attacco sulla maglia interna	Attachment on pin link Attacco sulla maglia esterna	Materials Materiali	Add. weight per attachment Peso aggiuntivo per attacco	Availability Disponibilità
		mm	" inches						
10 B-1	136	15,875	5/8	175		x	cs	0,002	○

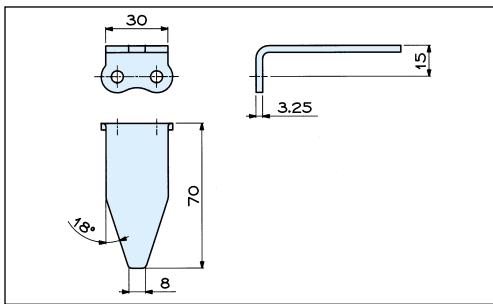

ISO N°	Regina Chain N° Codice Catena Regina	Pitch Passo		Attachment N° Codice Attacco	Attachment on roller link Attacco sulla maglia interna	Attachment on pin link Attacco sulla maglia esterna	Materials Materiali	Add. weight per attachment Peso aggiuntivo per attacco	Availability Disponibilità	Typical applications Applicazioni comuni
		mm	" inches							
12 A-1	A60	19,05	3/4	165		x	cs	0,051	○	K3

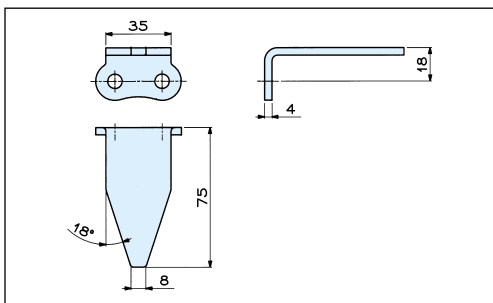

ISO N°	Regina Chain N° Codice Catena Regina	Pitch Passo		Attachment N° Codice Attacco	Attachment on roller link Attacco sulla maglia interna	Attachment on pin link Attacco sulla maglia esterna	Materials Materiali	Add. weight per attachment Peso aggiuntivo per attacco	Availability Disponibilità	Typical applications Applicazioni comuni
		mm	" inches							
16 A-1	A 80	25,40	1	148A		x	ss	0,072	○	K3

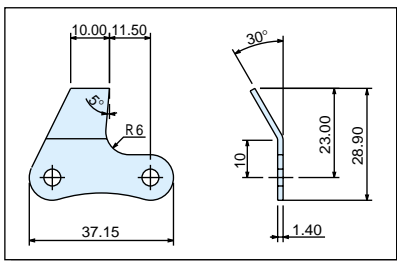
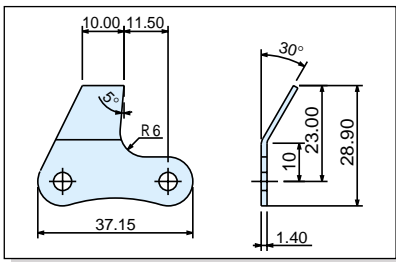
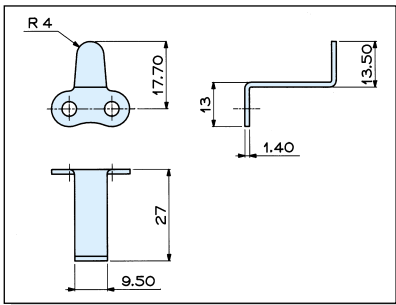
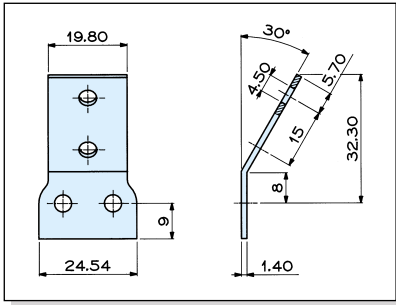
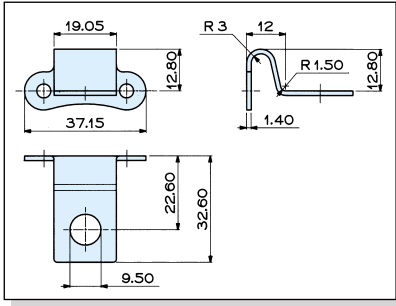
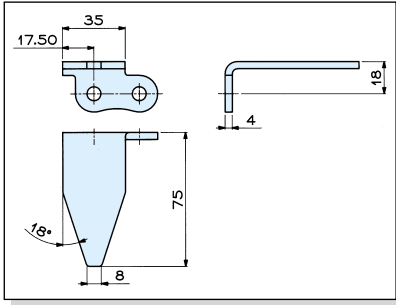

ISO N°	Regina Chain N° Codice Catena Regina	Pitch Passo		Attachment N° Codice Attacco	Attachment on roller link Attacco sulla maglia interna	Attachment on pin link Attacco sulla maglia esterna	Materials Materiali	Add. weight per attachment Peso aggiuntivo per attacco	Availability Disponibilità	Typical applications Applicazioni comuni
		mm	" inches							
16 A-1	A 80	25,40	1	149A		x	ss	0,072	○	K3

ISO N°	Regina Chain N° Codice Catena Regina	Pitch Passo		Attachment N° Codice Attacco	Attachment on roller link Attacco sulla maglia interna	Attachment on pin link Attacco sulla maglia esterna	Materials Materiali	Add. weight per attachment Peso aggiuntivo per attacco	Availability Disponibilità	Typical applications Applicazioni comuni
		mm	" inches							
208B	2126	25,40	1	142		x	cs	0,009	○	

ISO N°	Regina Chain N° Codice Catena Regina	Pitch Passo		Attachment N° Codice Attacco	Attachment on roller link Attacco sulla maglia interna	Attachment on pin link Attacco sulla maglia esterna	Materials Materiali	Add. weight per attachment Peso aggiuntivo per attacco	Availability Disponibilità	Typical applications Applicazioni comuni
		mm	" inches							
08 B-1	126	12,70	1/2	179A		x	ss	0,008	○	

ISO N°	Regina Chain N° Codice Catena Regina	Pitch Passo		Attachment N° Codice Attacco	Attachment on roller link Attacco sulla maglia interna	Attachment on pin link Attacco sulla maglia esterna	Materials Materiali	Add. weight per attachment Peso aggiuntivo per attacco	Availability Disponibilità	Typical applications Applicazioni comuni
		mm	" inches							
08 B-1	126	12,70	1/2	1020		x	cs	0,004	●	

ISO N°	Regina Chain N° Codice Catena Regina	Pitch Passo		Attachment N° Codice Attacco	Attachment on roller link Attacco sulla maglia interna	Attachment on pin link Attacco sulla maglia esterna	Materials Materiali	Add. weight per attachment Peso aggiuntivo per attacco	Availability Disponibilità	Typical applications Applicazioni comuni
		mm	" inches							
208B	2126	25,40	1	146		x	cs	0,003	○	F2
208B	2126	25,40	1	145		x	cs	0,003	○	

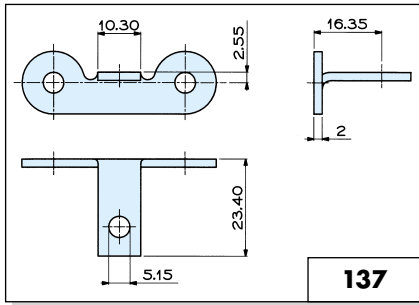
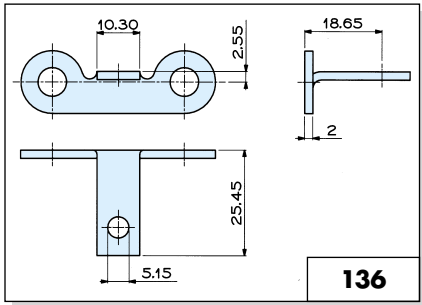

ISO N°	Regina Chain N° Codice Catena Regina	Pitch Passo		Attachment N° Codice Attacco	Attachment on roller link Attacco sulla maglia interna	Attachment on pin link Attacco sulla maglia esterna	Materials Materiali	Add. weight per attachment Peso aggiuntivo per attacco	Availability Disponibilità
		mm	" inches						
C210AS	C2050	31,75	1 1/4	136	x		cs	0,001	○
C210AS	C2050	31,75	1 1/4	137		x	cs	0,001	○

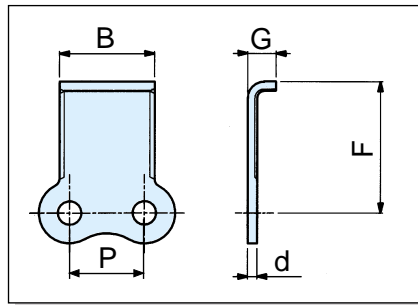
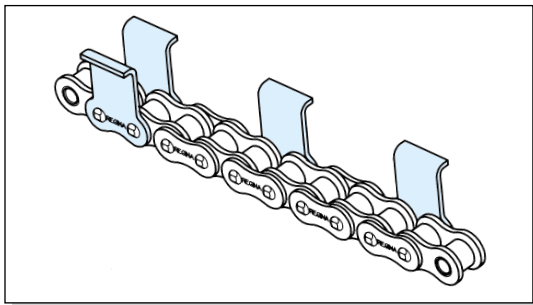

APPLICATION
APPLICAZIONE **G,L3**

ISO N°	Regina Chain N° Codice Catena Regina	Pitch Passo		Roller Diameter Diametro Rullo	Inside Width Larghezza interna	Attachment N° Codice Attacco	Attachment on roller link Attacco sulla maglia interna	Attachment on pin link Attacco sulla maglia esterna	Materials Materiali	Attachment dimensions Dimensioni attacchi				Add. weight per attachment Peso aggiuntivo per attacco	Availability Disponibilità
		mm	" inches							B mm	d mm	F mm	G mm		
08 B-1	126	12,70	1/2	8,51	7,75	1038		x	ss	23,05	1,53	10,00	13,00	0,006	●
08 B-1	126	12,70	1/2	8,51	7,75	1018		x	cs	23,05	1,40	8,40	13,15	0,004	○
10 B-1	136	15,875	5/8	10,16	9,65	156	x		cs	30,00	1,63	20,63	6,00	0,006	○
10 B-1	136	15,875	5/8	10,16	9,65	167		x	cs,ss	28,60	1,53	10,30	13,00	0,005	●
10 A-1	A 50	15,875	5/8	10,16	9,40	141		x	cs	20,00	2,00	27,60	6,00	0,008	●
12 A-1	A 60	19,05	3/4	11,91	12,57	193		x	cs	34,90	2,30	28,60	6,00	0,015	○

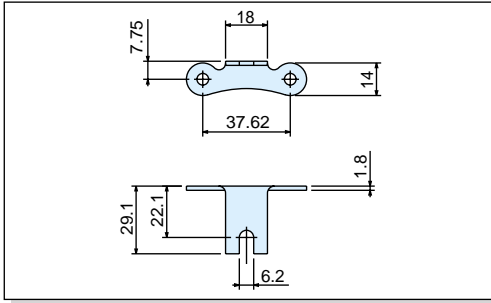

ISO N°	Regina Chain N° Codice Catena Regina	Pitch Passo		Attachment N° Codice Attacco	Attachment on roller link Attacco sulla maglia interna	Attachment on pin link Attacco sulla maglia esterna	Materials Materiali	Add. weight per attachment Peso aggiuntivo per attacco	Availability Disponibilità	
		mm	" inches							
210B	2136	31,75	1 1/4	148		x	cs		●	

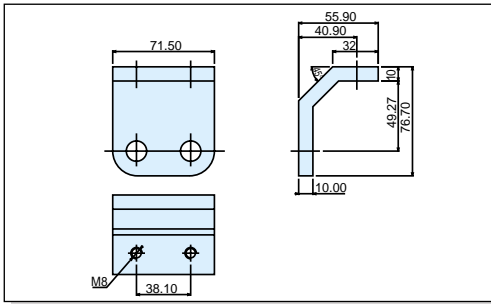

ISO N°	Regina Chain N° Codice Catena Regina	Pitch Passo		Attachment N° Codice Attacco	Attachment on roller link Attacco sulla maglia interna	Attachment on pin link Attacco sulla maglia esterna	Materials Materiali	Add. weight per attachment Peso aggiuntivo per attacco	Availability Disponibilità	Typical applications Applicazioni comuni
		mm	" inches							
24B-1	C157	38,10	1 1/2	144		x	cs		○	N1

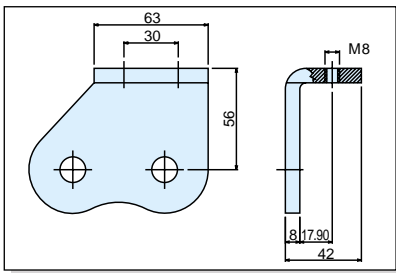

ISO N°	Regina Chain N° Codice Catena Regina	Pitch Passo		Attachment N° Codice Attacco	Attachment on roller link Attacco sulla maglia interna	Attachment on pin link Attacco sulla maglia esterna	Materials Materiali	Add. weight per attachment Peso aggiuntivo per attacco	Availability Disponibilità	Typical applications Applicazioni comuni
		mm	" inches							
32 A-1	A 160	50,80	2	138		x	cs		○	
32 A-1	A 160	50,80	2	137		x	cs		○	N1

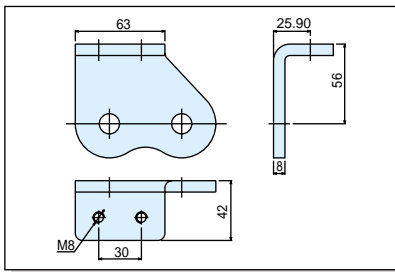

IRREGULAR SHAPES FORME IRREGOLARI

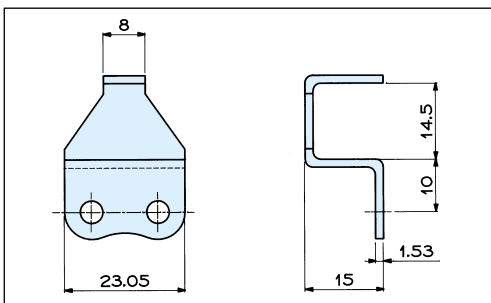

ISO N°	Regina Chain N° Codice Catena Regina	Pitch Passo		Attachment N° Codice Attacco	Attachment on roller link Attacco sulla maglia interna	Attachment on pin link Attacco sulla maglia esterna	Materials Materiali	Add. weight per attachment Peso aggiuntivo per attacco	Availability Disponibilità	Typical applications Applicazioni comuni
		mm	" inches							
08 B-1	126	12,70	1/2	1037		x	ss	0,0150	●	K

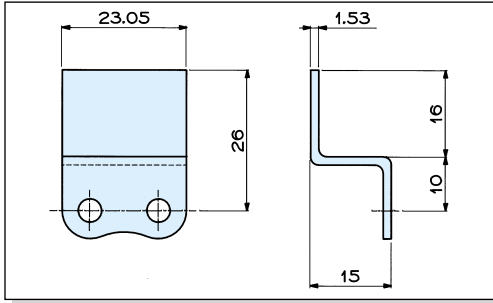

ISO N°	Regina Chain N° Codice Catena Regina	Pitch Passo		Attachment N° Codice Attacco	Attachment on roller link Attacco sulla maglia interna	Attachment on pin link Attacco sulla maglia esterna	Materials Materiali	Add. weight per attachment Peso aggiuntivo per attacco	Availability Disponibilità	
		mm	" inches							
08 B-1	126	12,70	1/2	1036 A		x	ss	0,011	●	K

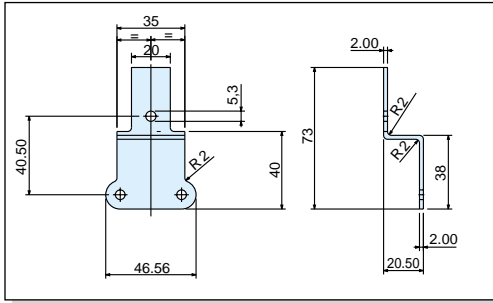

ISO N°	Regina Chain N° Codice Catena Regina	Pitch Passo		Attachment N° Codice Attacco	Attachment on roller link Attacco sulla maglia interna	Attachment on pin link Attacco sulla maglia esterna	Materials Materiali	Add. weight per attachment Peso aggiuntivo per attacco	Availability Disponibilità
		mm	" inches						
C210AS	C2050	31,75	1 1/4	163		x	cs	0,03	○

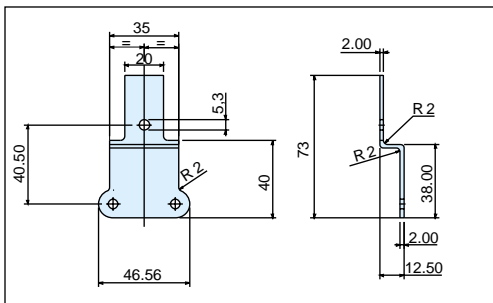

ISO N°	Regina Chain N° Codice Catena Regina	Pitch Passo		Attachment N° Codice Attacco	Attachment on roller link Attacco sulla maglia interna	Attachment on pin link Attacco sulla maglia esterna	Materials Materiali	Add. weight per attachment Peso aggiuntivo per attacco	Availability Disponibilità
		mm	" inches						
C210AS	C2050	31,75	1 1/4	162		x	cs	0,03	○

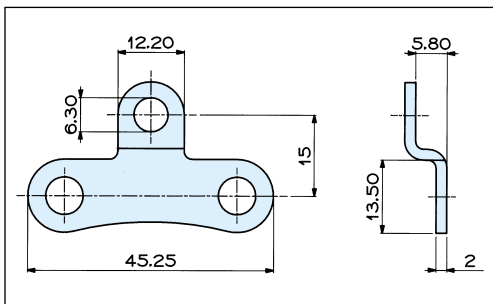

ISO N°	Regina Chain N° Codice Catena Regina	Pitch Passo		Attachment N° Codice Attacco	Attachment on roller link Attacco sulla maglia interna	Attachment on pin link Attacco sulla maglia esterna	Materials Materiali	Add. weight per attachment Peso aggiuntivo per attacco	Availability Disponibilità
		mm	" inches						
210A	2050	31,75	1 1/4	136		x	cs	0,0010	●

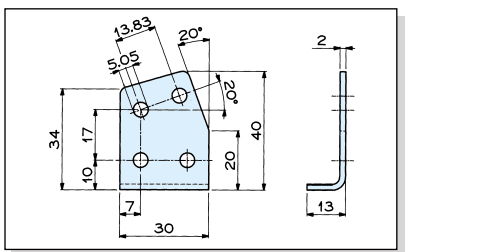

ISO N°	Regina Chain N° Codice Catena Regina	Pitch Passo		Attachment N° Codice Attacco	Attachment on roller link Attacco sulla maglia interna	Attachment on pin link Attacco sulla maglia esterna	Materials Materiali	Add. weight per attachment Peso aggiuntivo per attacco	Availability Disponibilità	Typical applications Applicazioni comuni
		mm	" inches							
10 A-1	A 50	15,875	5/8	145A		x	ss	0,0170	○	J1
10 A-1	A 50	15,875	5/8	146A		x	ss	0,0170	○	

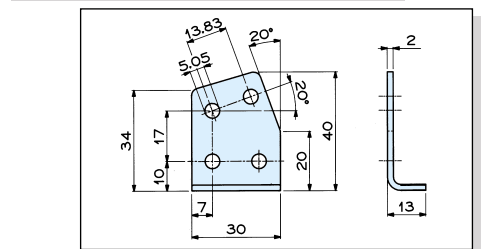

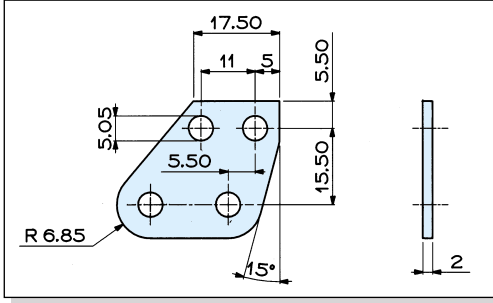

ISO N°	Regina Chain N° Codice Catena Regina	Pitch Passo		Attachment N° Codice Attacco	Attachment on roller link Attacco sulla maglia interna	Attachment on pin link Attacco sulla maglia esterna	Materials Materiali	Add. weight per attachment Peso aggiuntivo per attacco	Availability Disponibilità	Typical applications Applicazioni comuni
		mm	" inches							
10 A-1	A 50	15,875	5/8	148A		x	ss	0,0060	○	J1

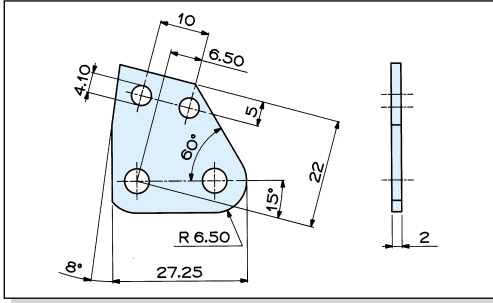

ISO N°	Regina Chain N° Codice Catena Regina	Pitch Passo		Attachment N° Codice Attacco	Attachment on roller link Attacco sulla maglia interna	Attachment on pin link Attacco sulla maglia esterna	Materials Materiali	Add. weight per attachment Peso aggiuntivo per attacco	Availability Disponibilità	Typical applications Applicazioni comuni
		mm	" inches							
10 A-1	A 50	15,875	5/8	150A		x	ss	0,0050	○	J1

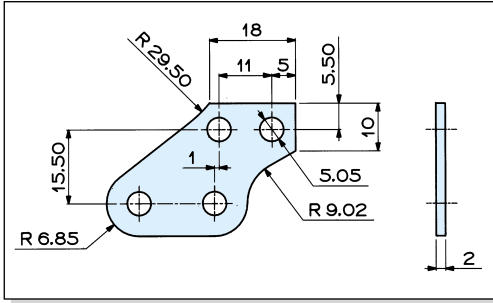

ISO N°	Regina Chain N° Codice Catena Regina	Pitch Passo		Attachment N° Codice Attacco	Attachment on roller link Attacco sulla maglia interna	Attachment on pin link Attacco sulla maglia esterna	Materials Materiali	Add. weight per attachment Peso aggiuntivo per attacco	Availability Disponibilità	Typical applications Applicazioni comuni
		mm	" inches							
10 A-1	A 50	15,875	5/8	151A		x	ss	0,0060	○	J1

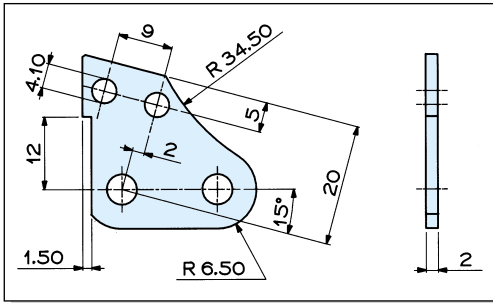

ISO N°	Regina Chain N° Codice Catena Regina	Pitch Passo		Attachment N° Codice Attacco	Attachment on roller link Attacco sulla maglia interna	Attachment on pin link Attacco sulla maglia esterna	Materials Materiali	Add. weight per attachment Peso aggiuntivo per attacco	Availability Disponibilità	Typical applications Applicazioni comuni
		mm	" inches							
10 A-1	A 50	15,875	5/8	149A		x	ss	0,0040	○	J1

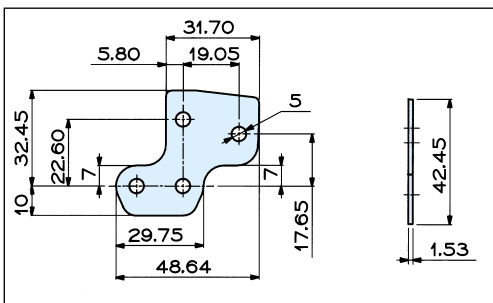

ISO N°	Regina Chain N° Codice Catena Regina	Pitch Passo		Attachment N° Codice Attacco	Attachment on roller link Attacco sulla maglia interna	Attachment on pin link Attacco sulla maglia esterna	Materials Materiali	Add. weight per attachment Peso aggiuntivo per attacco	Availability Disponibilità	Typical applications Applicazioni comuni
		mm	" inches							
10 B-1	136	15,875	5/8	178		x	cs	0,0110	○	

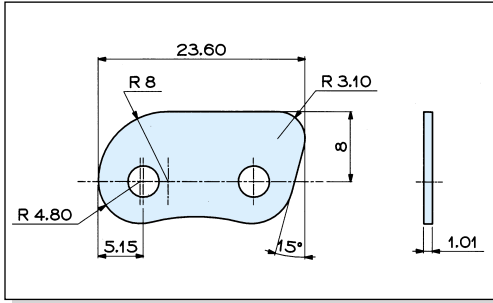

ISO N°	Regina Chain N° Codice Catena Regina	Pitch Passo		Attachment N° Codice Attacco	Attachment on roller link Attacco sulla maglia interna	Attachment on pin link Attacco sulla maglia esterna	Materials Materiali	Add. weight per attachment Peso aggiuntivo per attacco	Availability Disponibilità	
		mm	" inches							
10 A-1	A 50	15,875	5/8	137		x	cs	0,0010	●	

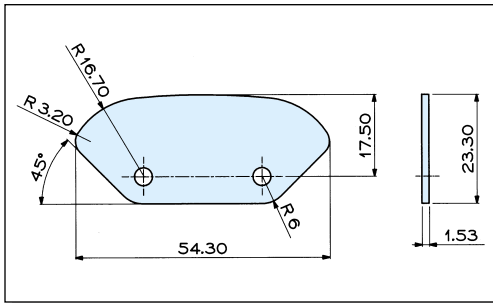

ISO N°	Regina Chain N° Codice Catena Regina	Pitch Passo		Attachment N° Codice Attacco	Attachment on roller link Attacco sulla maglia interna	Attachment on pin link Attacco sulla maglia esterna	Materials Materiali	Add. weight per attachment Peso aggiuntivo per attacco	Availability Disponibilità	Typical applications Applicazioni comuni
		mm	" inches							
C208AS	C2040	25,40	1	141A		x	ss	0,0070	●	F6

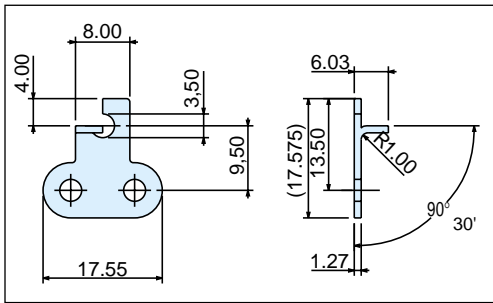

ISO N°	Regina Chain N° Codice Catena Regina	Pitch Passo		Attachment N° Codice Attacco	Attachment on roller link Attacco sulla maglia interna	Attachment on pin link Attacco sulla maglia esterna	Materials Materiali	Add. weight per attachment Peso aggiuntivo per attacco	Availability Disponibilità	Typical applications Applicazioni comuni
		mm	" inches							
06 B-1	C121	9,525	3/8	1022A		x	ss	0,0004	●	E1

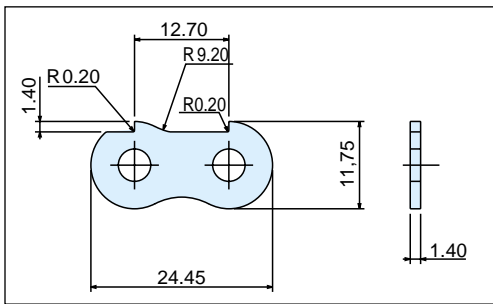

ISO N°	Regina Chain N° Codice Catena Regina	Pitch Passo		Attachment N° Codice Attacco	Attachment on roller link Attacco sulla maglia interna	Attachment on pin link Attacco sulla maglia esterna	Materials Materiali	Add. weight per attachment Peso aggiuntivo per attacco	Availability Disponibilità	Typical applications Applicazioni comuni
		mm	" inches							
08 B-1	126	12,70	1/2	1005	&	x	cs	0,002	○	L1

& Available also on roller link / Disponibile anche su maglia interna

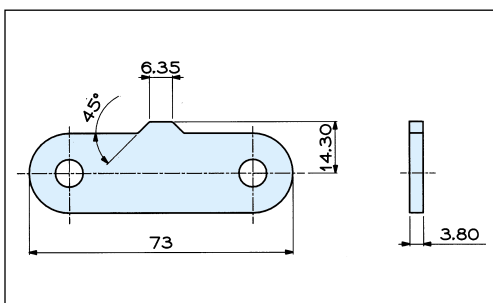

ISO N°	Regina Chain N° Codice Catena Regina	Pitch Passo		Attachment N° Codice Attacco	Attachment on roller link Attacco sulla maglia interna	Attachment on pin link Attacco sulla maglia esterna	Materials Materiali	Add. weight per attachment Peso aggiuntivo per attacco	Availability Disponibilità	Typical applications Applicazioni comuni
		mm	" inches							
C216A-H	C2080H	50,80	2	167		x	cs	0,0010	●	K5

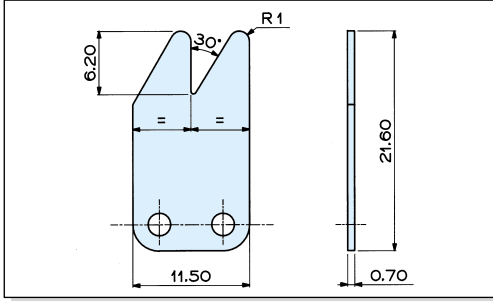

ISO N°	Regina Chain N° Codice Catena Regina	Pitch Passo		Attachment N° Codice Attacco	Attachment on roller link Attacco sulla maglia interna	Attachment on pin link Attacco sulla maglia esterna	Materials Materiali	Add. weight per attachment Peso aggiuntivo per attacco	Availability Disponibilità	Typical applications Applicazioni comuni
		mm	" inches							
04 C-1	A25 (25L)	6,35	1/4	136A		x	ss	0,0010	○	l2

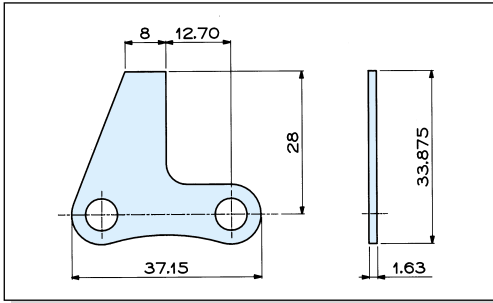

ISO N°	Regina Chain N° Codice Catena Regina	Pitch Passo		Attachment N° Codice Attacco	Attachment on roller link Attacco sulla maglia interna	Attachment on pin link Attacco sulla maglia esterna	Materials Materiali	Add. weight per attachment Peso aggiuntivo per attacco	Availability Disponibilità	Typical applications Applicazioni comuni
		mm	" inches							
208 B	2126	25,40	1	143	x		cs	0,0040	○	

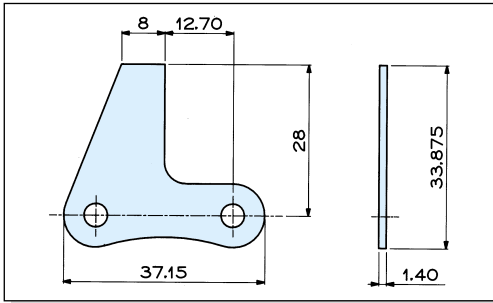

ISO N°	Regina Chain N° Codice Catena Regina	Pitch Passo		Attachment N° Codice Attacco	Attachment on roller link Attacco sulla maglia interna	Attachment on pin link Attacco sulla maglia esterna	Materials Materiali	Add. weight per attachment Peso aggiuntivo per attacco	Availability Disponibilità	Typical applications Applicazioni comuni
		mm	" inches							
208 B	2126	25,40	1	139		x	cs	0,0040	○	

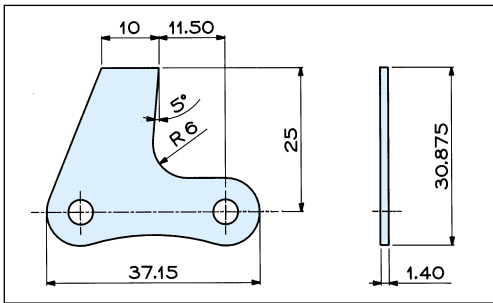

ISO N°	Regina Chain N° Codice Catena Regina	Pitch Passo		Attachment N° Codice Attacco	Attachment on roller link Attacco sulla maglia interna	Attachment on pin link Attacco sulla maglia esterna	Materials Materiali	Add. weight per attachment Peso aggiuntivo per attacco	Availability Disponibilità	Typical applications Applicazioni comuni
		mm	" inches							
208 B	2126	25,40	1	138		x	cs	0,0030	●	

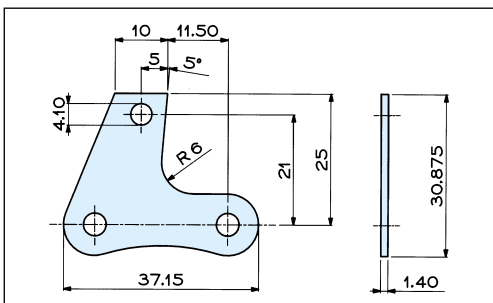

ISO N°	Regina Chain N° Codice Catena Regina	Pitch Passo		Attachment N° Codice Attacco	Attachment on roller link Attacco sulla maglia interna	Attachment on pin link Attacco sulla maglia esterna	Materials Materiali	Add. weight per attachment Peso aggiuntivo per attacco	Availability Disponibilità	Typical applications Applicazioni comuni
		mm	" inches							
208 B	2126	25,40	1	140		x	cs	0,0030	●	