

Standard types

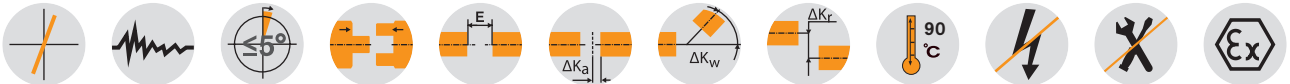

For legend of pictogram please refer to flapper on the cover



ROTEX® GS 5 - 38

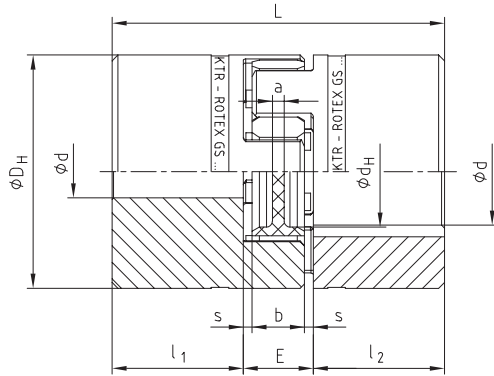

ROTEX® GS 42 - 90

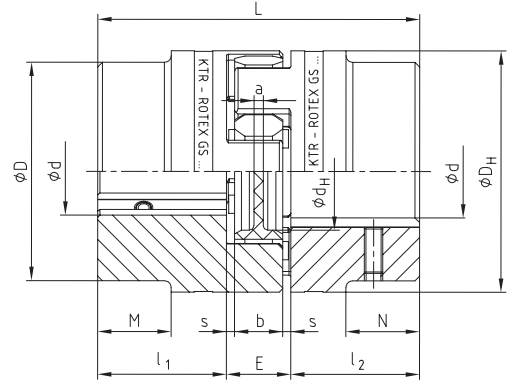

Types of hubs:

Type 1.0

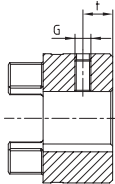

with feather keyway and setscrew

Type 1.1

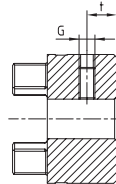

without feather keyway, with setscrew

Type 1.2

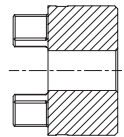

without feather keyway and without setscrew

ROTEX® GS standard types - For size 5 to 38 hub material aluminium/for size 42 to 90 hub material steel

Size	Spider GS ¹⁾ torque T _{KN} [Nm] for 98 ShA	d _{max.} for hub type			Dimensions [mm]											Setscrew DIN EN ISO 4029		
		1.0	1.1	1.2	D	D _H	d _H	L	l ₁ , l ₂	M, N	E	b	s	a	G	t	T _A [Nm]	
5	0.9	-	6	5	-	10	-	15	5	-	5	4	0.5	4.0	M2	2.5	0.35	
7	2.0	7	7	7	-	14	-	22	7	-	8	6	1.0	6.0	M3	3.5	0.6	
9	5.0	10	11	11	-	20	7.2	30	10	-	10	8	1.0	1.5	M4	5.0	1.5	
12	9.0	12	12	12	-	25	8.5	34	11	-	12	10	1.0	3.5	M4	5.0	1.5	
14	12.5	16	16	16	-	30	10.5	35	11	-	13	10	1.5	2.0	M4	5.0	1.5	
19	21	24	-	-	-	40	18	66	25	-	16	12	2.0	3.0	M5	10	2.0	
24	60	32	-	-	-	55	27	78	30	-	18	14	2.0	3.0	M5	10	2.0	
28	160	38	-	-	-	65	30	90	35	-	20	15	2.5	4.0	M8	15	10	
38	325	45	-	-	-	80	38	114	45	-	24	18	3.0	4.0	M8	15	10	
42	450	55	-	-	85	95	46	126	50	28	26	20	3.0	4.0	M8	20	10	
48	525	62	-	-	95	105	51	140	56	32	28	21	3.5	4.0	M8	20	10	
55	685	74	-	-	110	120	60	160	65	37	30	22	4.0	4.5	M10	20	17	
65	940	80	-	-	115	135	68	185	75	47	35	26	4.5	4.5	M10	20	17	
75	1920	95	-	-	135	160	80	210	85	53	40	30	5.0	5.0	M10	25	17	
90	3600	110	-	-	160	200	104	245	100	62	45	34	5.5	6.5	M12	30	40	

¹⁾ For selections see page 22 et seqq./other spiders see page 125 and following

Ordering example:	ROTEX® GS 24	98 ShA-GS	d 20	2.5 - Ø24		1.0 - Ø20	
	Coupling size	Spider hardness	Optional: Bore in spider	Hub type	Finish bore	Hub type	Finish bore

Types of hubs:

Type 2.0
Type 2.1

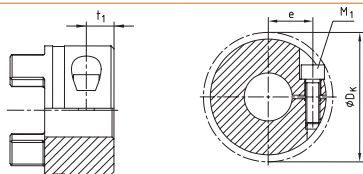

Size 5 to 14
Type 2.0: single slotted clamping hub **without** feather keyway (only for ATEX cat. 3), torque depending on bore Ø
Type 2.1: single slotted clamping hub **with** feather keyway

Type 2.5
Type 2.6

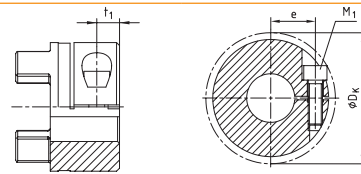

from size 19
Type 2.5: double slotted clamping hub **without** feather keyway (only for ATEX cat. 3), torque depending on bore Ø
Type 2.6: double slotted clamping hub **with** feather keyway

ROTEX® GS standard types - For size 5 to 38 hub material aluminium/for size 42 to 90 hub material steel

Size	Spider GS ¹⁾ torque T _{KN} [Nm] for 98 ShA	d _{max.} for hub type				Dimensions [mm]													Clamping screws DIN EN ISO 4762 (ROTEX® GS 5 - DIN EN ISO 1207)				
		2.0	2.1	2.5	2.6	D	D _H	d _H	L	l ₁ , l ₂	M, N	E	b	s	a	M ₁	t ₁	e	DK	T _A [Nm]			
5	0.9	5	-	-	-	-	10	-	15	5	-	5	4	0.5	4.0	M1.2	2.5	3.5	11.4	- ²⁾			
7	2.0	7	7	-	-	-	14	-	22	7	-	8	6	1.0	6.0	M2	3.5	5.0	16.5	0.37			
9	5.0	11	11	-	-	-	20	7.2	30	10	-	10	8	1.0	1.5	M2.5	5.0	7.5	23.4	0.76			
12	9.0	12	12	-	-	-	25	8.5	34	11	-	12	10	1.0	3.5	M3	5.0	9.0	27.5	1.34			
14	12.5	16	16	-	-	-	30	10.5	35	11	-	13	10	1.5	2.0	M3	5.0	11.5	32.2	1.34			
19	21	-	-	24	24	-	40	18	66	25	-	16	12	2.0	3.0	M6	11.0	14.5	46	10.5			
24	60	-	-	28	28	-	55	27	78	30	-	18	14	2.0	3.0	M6	10.5	20.0	57.5	10.5			
28	160	-	-	38	38	-	65	30	90	35	-	20	15	2.5	4.0	M8	11.5	25.0	73	25			
38	325	-	-	45	45	-	80	38	114	45	-	24	18	3.0	4.0	M8	15.5	30.0	83.5	25			
42	450	-	-	50	45	85	95	46	126	50	28	26	20	3.0	4.0	M10	18	32.0	93.5	69			
48	525	-	-	55	55	95	105	51	140	56	32	28	21	3.5	4.0	M12	21	36.0	105	120			
55	685	-	-	68	68 ³⁾	110	120	60	160	65	37	30	22	4.0	4.5	M12	26	42.5	119.5	120			
65	940	-	-	70	70 ³⁾	115	135	68	185	75	47	35	26	4.5	4.5	M12	33	45.0	124	120			
75	1920	-	-	80	80	135	160	80	210	85	53	40	30	5.0	5.0	M16	36	51.0	147.5	295			
90	3600	-	-	90	90	160	200	104	245	100	62	45	34	5.5	6.5	M20	40	60.0	176	580			

¹⁾ For selections see page 22 et seq./other spiders see page 125 and following
²⁾ No T_A defined (slotted screw)
³⁾ From Ø60 keyway opposite the clamping screw

Review of shaft-hub-connection: Friction torques T_R [Nm] for hub type 2.0

Size	Ø3	Ø4	Ø5	Ø6	Ø7	Ø8	Ø9	Ø10	Ø11	Ø12	Ø13	Ø14	Ø15	Ø16
7	0.7	0.9	1.1	1.2	1.4									
9		1.6	1.9	2.2	2.6	2.9	3.2	3.5	3.8					
12		2.4	2.9	3.4	3.9	4.4	4.9	5.4	5.8	6.3				
14			3.1	3.6	4.2	4.7	5.2	5.7	6.2	6.7	7.1	7.6	8.0	8.5

Review of shaft-hub-connection: Friction torques T_R [Nm] for hub type 2.5

Size	Ø8	Ø10	Ø11	Ø14	Ø15	Ø16	Ø18	Ø19	Ø20	Ø22	Ø24	Ø25	Ø28	Ø30	Ø32	Ø35	Ø38	Ø40	Ø42	Ø45	Ø48	Ø50	Ø55	Ø60	Ø65	Ø70	Ø75	Ø80	Ø85	Ø90	
19	19	23	25	31	33	35	39	41	42	46 ⁴⁾	49 ⁴⁾																				
24		24	26	33	35	37	41	43	45	48	52	54	59																		
28			63	67	71	79	82	86	94	101	105	115	122	129	139	148															
38				67	71	79	83	87	95	102	106	117	124	131	142	152	158	165	175												
42							188	197	214	231	240	264	281	297	320	343	358	373	395	417	431										
48											356	394	418	442	478	513	536	558	592	624	646	699									
55												456	493	529	553	577	611	646	668	724	778	830	882								
65															499	536	560	584	620	655	677	734	789	842	895	946					
75																			1107	1175	1242	1287	1396	1503	1607	1709	1810	1908	2005		
90																				1764	1876	1985	2057	2235	2409	2579	2746	2911	3072	3231	3387

⁴⁾ Clamping hub single slotted with 2-off clamping screws M4 and dimension e = 15, T_A = 2.9 Nm

ROTEX® GS Compact Backlash-free jaw couplings

Compact design



For legend of pictogram please refer to flapper on the cover

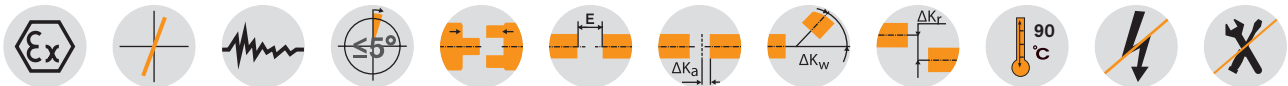

ROTEX® GS Compact - Hub material aluminium

Size	Spider GS ¹⁾ torque T _{KN} [Nm]				Dimensions [mm]										Clamping screws DIN EN ISO 4762			
	80 ShA	92 ShA	98 ShA	64 ShD	d _{max.}	D _H	DK	L	l ₁ , l ₂	E	b	s	d _H	t	e	M	T _A [Nm]	
Single slotted hub type 2.8/2.9																		
7	0.7	1.2	2.0	2.4	7	14	16.6	18	5	8	6	1	-	2.5	5	M2	0.37	
8	0.5	-	2.0	2.4	8	15	17.3	20	7	6	5	0.5	6.2	4	5.4	M2	0.52	
9	1.8	3.0	5.0	6	9	20	21.3	24	7	10	8	1	-	3.5	6.7	M2.5	0.76	
12	3.0	5.0	9.0	12	12	25	26.2	26	7	12	10	1	-	3.5	8.3	M3	1.34	
13	3.6	-	11	14.5	12.7	25	25.7	26	8	10	8	1	10	4	8	M3	1.9	
14	4.0	7.5	12.5	16	16 ²⁾	30	31.6	32	9.5	13	10	1.5	-	4.5	10	M4	2.9	
16	5.0	-	15	19	16	30	32.5	32	10.3	11.4	9.4	1	14	5.3	10.5	M4	4.1	
19	6.0	12.0	21.0	26.0	24 ²⁾	40	45.5	50	17	16	12	2	-	9	14.0	M6	10	
Axially slotted hub type 2.8/2.9																		
24	-	35	60	75	32	55	57.5	54	18	18	14	2	-	11	20.0	M6	10	
28	-	95	160	200	35	65	69.0	62	21	20	15	2.5	-	12	23.8	M8	25	
38	-	190	325	405	45	80	86.0	76	26	24	18	3	-	15	29.5	M10	49	

Review of shaft-hub-connection: Friction torques T_R [Nm] for hub type 2.8

Size	Ø3	Ø4	Ø5	Ø6	Ø7	Ø8	Ø9	Ø10	Ø11	Ø12	Ø14	Ø15	Ø16	Ø18	Ø19	Ø20	Ø24	Ø25	Ø28	Ø30	Ø32	Ø35	Ø38	Ø40	Ø42	Ø45	
Single slotted hub type 2.8																											
7	0.7	0.9	1.1	1.2	1.4																						
8	1.0	1.2	1.5	1.8	2.0	2.3																					
9		1.5	1.8	2.1	2.4	2.7	3.0																				
12		2.3	2.8	3.3	3.8	4.3	4.7	5.2	5.6	6.0																	
13		3.1	3.9	4.6	5.2	5.9	6.5	7.1	7.8	8.4																	
14			5.0	5.9	6.8	7.7	8.5	9.4	10.2	11.0	7.2 ²⁾	7.7 ²⁾	8.1 ²⁾														
16			7.2	8.5	9.8	11.0	12.2	13.4	14.6	15.7	17.9	19.0	20.0														
19						18.7	20.8	22.9	24.9	26.9	30.8	32.7	34.6	38.2	40.0	41.8	36.0 ²⁾										
Axially slotted hub type 2.8																											
24								34	37	41	48	51	54	61	64	68	81	85	95	102	109						
28											87	93	100	112	118	124	149	156	174	187	199	218					
38											148	158	178	188	198	237	247	277	296	316	346	375	395	415	444		

¹⁾ For selections see page 22 et seqq./other spiders see page 125 and following

²⁾ Size 14 with screw M3 and dimension e = 10.4/D_K = 30.5/T_A = 1.34 Nm; size 19 with screw M5 and dimension e = 15.5/D_K = 47mm/T_A = 6 Nm

Ordering example:

ROTEX® GS 38	Compact	98 ShA-GS	d 28	2.8 - Ø28	2.8 - Ø45		
Coupling size	Type	Spider hardness	Optional: Bore in spider	Hub type	Finish bore	Hub type	Finish bore

ROTEX® GS 8, 13, 16
Compact
single slotted type 2.8

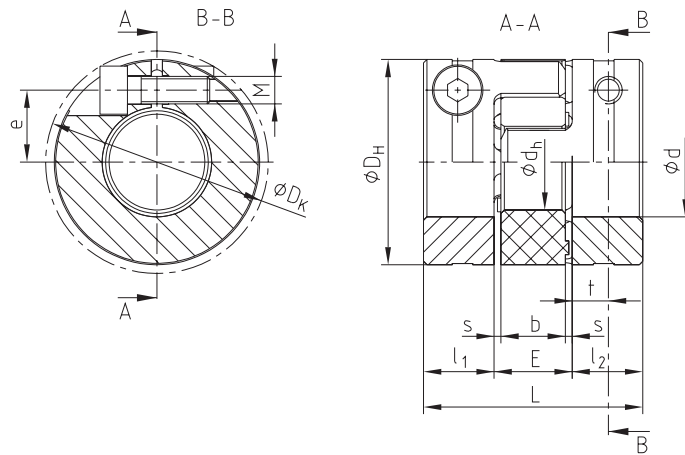

ROTEX® GS 7, 9, 12, 14, 19
Compact
single slotted type 2.8

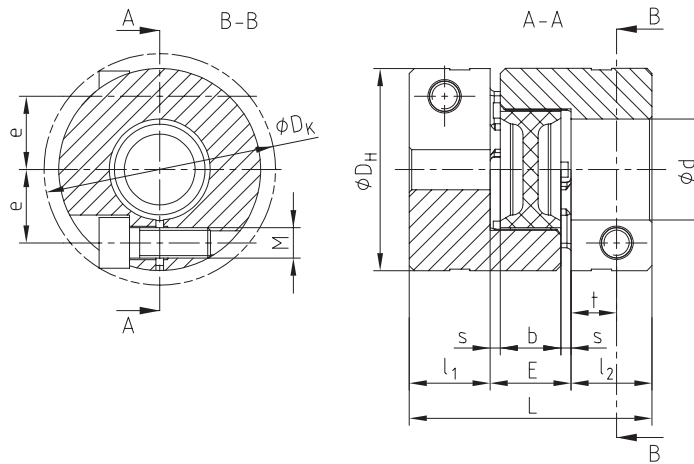

ROTEX® GS 24 - 38
Compact
axially slotted type 2.8

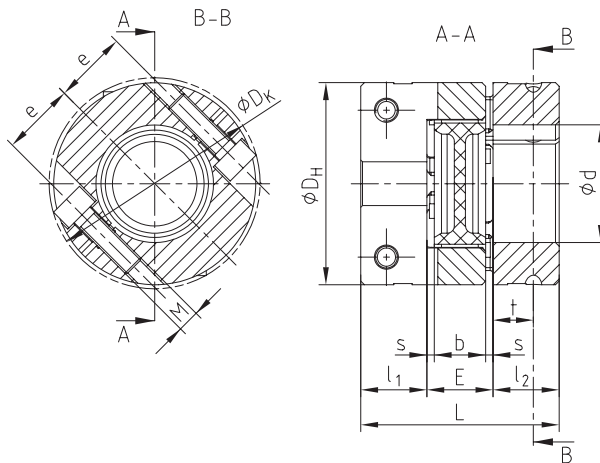

Types of hubs

Type 2.8

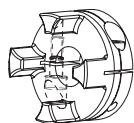

Short-type clamping hub C with axial slot, without feather keyway
Type 2.8 from size 24 as standard, size 7 - 19 type 2.8 single slotted

Type 2.9

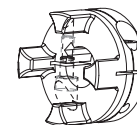

Short-type clamping hub C with axial slot, with feather keyway
Type 2.9 from size 24 as standard, size 7 - 19 type 2.9 single slotted

ROTEX® GS Clamping ring hubs light Backlash-free jaw couplings

Integrated clamping system made of aluminium

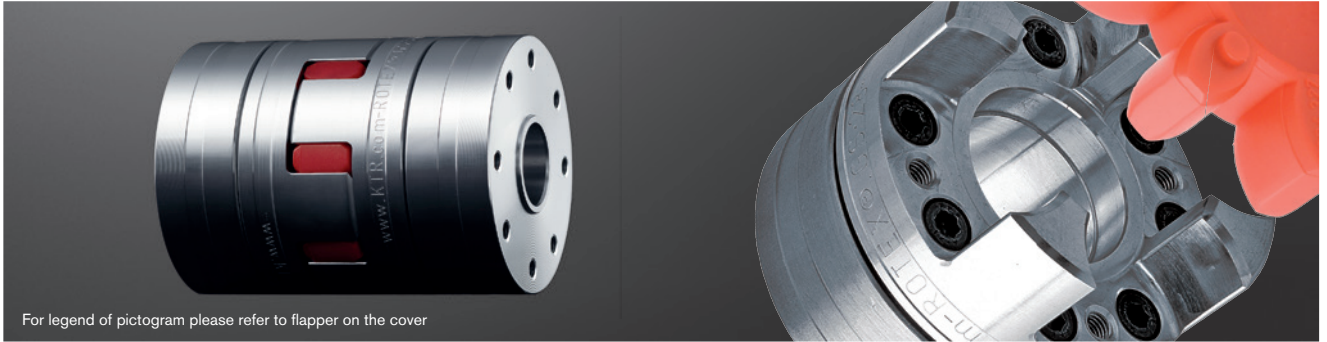

For legend of pictogram please refer to flapper on the cover



Extraction thread M₁ between clamping screws

Clamping ring hub light with block mounting (hub and clamping ring mounted as a block)

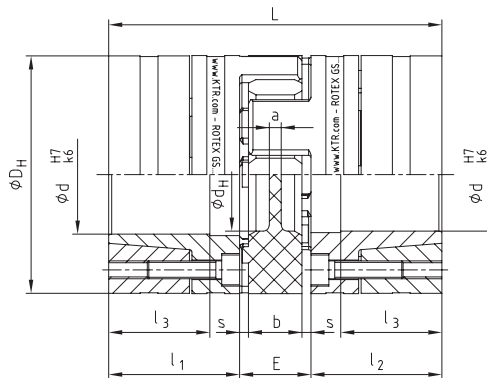

ROTEX® GS clamping ring hubs light

Size	Spider GS ¹⁾ torque T _{KN} [Nm]			Dimensions [mm]										Clamping screws DIN EN ISO 4762			Weight per hub with max. bore [kg]	Mass moment of inertia per hub with max. bore [kgm ²]	
	92 ShA	98 ShA	64 ShD	d _{max}	D _H ²⁾	d _H	L	l _{1,2}	l ₃	E	b	s	a	M	z = number	T _A [Nm]			M ₁
13	-	11	14.5	13	25	10	34	12	9	10	8	1	-	M2	6	0.37	M2	0.014	1.39 x 10 ⁻⁶
14	7.5	12.5	16.0	14	30	10.5	50	18.5	13.5	13	10	1.5	2.0	M3	4	1.34	M3	0.032	0.04 x 10 ⁻⁴
19	12	21	26	20	40	18	66	25	18	16	12	2.0	3.0	M4	6	3	M4	0.077	0.19 x 10 ⁻⁴
24	35	60	75	32	55	27	78	30	22	18	14	2.0	3.0	M5	4	6	M5	0.162	0.78 x 10 ⁻⁴
28	95	160	200	38	65	30	90	35	27	20	15	2.5	4.0	M5	8	6	M5	0.240	1.70 x 10 ⁻⁴
38	190	325	405	48	80	38	114	45	35	24	18	3.0	4.0	M6	8	10	M6	0.490	5.17 x 10 ⁻⁴
42	265	450	560	51	95	46	126	50	35	26	20	3.0	4.0	M8	4	25	M8	0.772	11.17 x 10 ⁻⁴
48	310	525	655	55	105	51	140	56	41	28	21	3.5	4.0	M10	4	49	M10	1.066	18.81 x 10 ⁻⁴

¹⁾ For selections see page 22 et seqq./other spiders see page 125 and following

²⁾ ØD_H + 2 mm with high speeds for expansion of spider

Review of shaft-hub-connection: Friction torques T_R [Nm] for hub type 6.0 light

Size		Ø3	Ø4	Ø5	Ø6	Ø8	Ø9	Ø10	Ø11	Ø14	Ø15	Ø16	Ø19	Ø20	Ø24	Ø25	Ø28	Ø30	Ø32	Ø35	Ø38	Ø40	Ø42	Ø45	Ø48	Ø50	Ø55 [*]	
13	H7/k6	1.3 ³⁾	2.3 ³⁾	4.3 ³⁾	5.4 ³⁾	10 ³⁾	6.3	8.9	10.6																			
	H7/h6						2.4	4.8	5.4																			
14	H7/k6				8.2	13.1	18.7	20.5	25.9	36.2																		
	H7/h6				5.8	9.5	15.7	16.6	21.6	24.7																		
19	H7/k6							33	41	59	71	51	80	92														
	H7/h6							27	35	52	65	39	68	81														
24	H7/k6									84	99	93	139	157	160	177	232	177 ⁴⁾										
	H7/h6									75	92	79	125	145	119	136	190	147 ⁴⁾										
28	H7/k6											140	207	188	289	316	355	414	324	404	422							
	H7/h6											121	187	157	263	293	318	381	245	324	343							
38	H7/k6													290	439	480	567	656	617	759	733	825	922	808	937			
	H7/h6													247	403	447	530	626	499	636	606	696	792	678	809			
42	H7/k6																	651	752	747	916	1001	1115	1044	1218	1404	1432	
	H7/h6																	574	681	613	774	881	1001	888	1058	1241	1295	
48	H7/k6																	765	822	927	1121	1220	1357	1318	1536	1768	1535	1823
	H7/h6																	678	760	837	1047	1085	1231	1128	1339	1566	1331	1475

* Standard bore tolerance H7, special tolerances on request * From Ø55 tolerance G7/m6

The friction torque is reduced with bigger fitting tolerances. Steel or nodular iron with a yield strength of approx. 250 N/mm² or more can be used as shaft material. For strength calculation of shaft/hollow shaft see KTR standard 45510 on our homepage www.ktr.com.

³⁾ Taper of hub with slot

⁴⁾ Clamping ring hub with screws M3, z = 8 and T_A = 2.9 Nm

Ordering example:	ROTEX® GS 24	98 ShA-GS	d 20	6.0 light - Ø24		6.0 light - Ø20	
	Coupling size	Spider hardness	Optional: Bore in spider	Hub type	Finish bore	Hub type	Finish bore

ROTEX® GS Clamping ring hubs made of steel

Backlash-free jaw couplings

Integrated clamping system made of steel

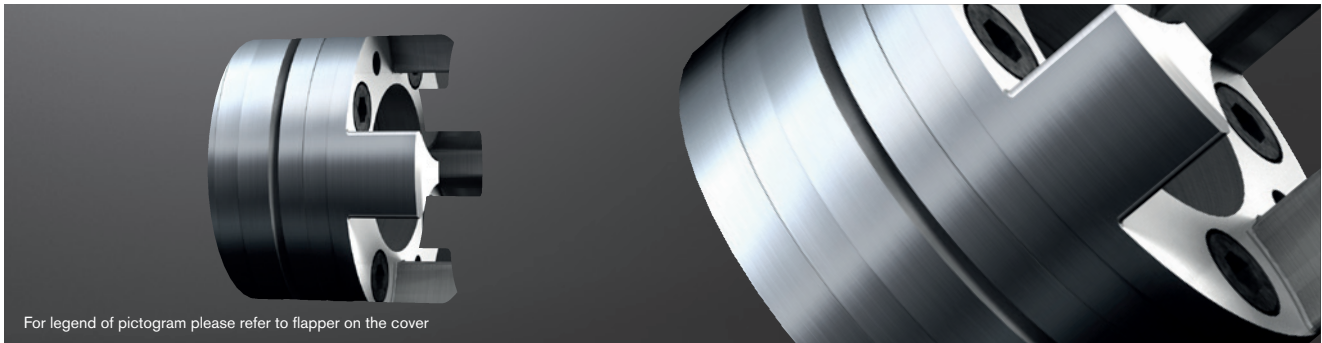

For legend of pictogram please refer to flapper on the cover

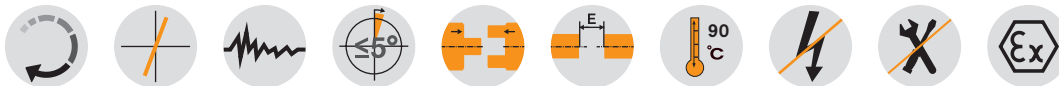

Extraction thread M₁ between clamping screws

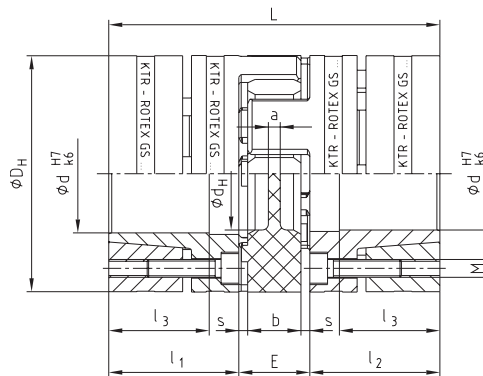

ROTEX® GS clamping ring hubs steel

Size	Spider GS ¹⁾ torque T _{KN} [Nm]			Dimensions [mm]										Clamping screws DIN EN ISO 4762			Weight per hub with max. bore [kg]	Mass moment of inertia per hub with max. bore [kgm ²]
	98 ShA	64 ShD	72 ShD	d _{max}	D _H ²⁾	d _H	L	l ₁ , l ₂	l ₃	E	b	s	a	M	z = number	T _A [Nm]		
19	21	26	—	20	40	18	66	25 18	16	12	2.0	3.0	M4	6	4.1	M4	0.179	0.44 x 10 ⁻⁴
24	60	75	97	28	55	27	78	30 22	18	14	2.0	3.0	M5	4	8.5	M5	0.399	1.91 x 10 ⁻⁴
28	160	200	260	38	65	30	90	35 27	20	15	2.5	4.0	M5	8	8.5	M5	0.592	4.18 x 10 ⁻⁴
38	325	405	525	48	80	38	114	45 35	24	18	3.0	4.0	M6	8	14	M6	1.225	12.9 x 10 ⁻⁴
42	450	560	728	51	95	46	126	50 35	26	20	3.0	4.0	M8	4	41	M8	2.30	31.7 x 10 ⁻⁴
48	525	655	852	55	105	51	140	56 41	28	21	3.5	4.0	M10	4	69	M10	3.08	52.0 x 10 ⁻⁴
55	685	825	1072	70	120	60	160	65 45	30	22	4.0	4.5	M10	4	69	M10	4.67	103.0 x 10 ⁻⁴
65	940	1175	1527	70	135	68	185	75 55	35	26	4.5	4.5	M12	4	120	M12	6.70	191.0 x 10 ⁻⁴
75	1920	2400	3120	80	160	80	210	85 63	40	30	5.0	5.0	M12	5	120	M12	9.90	396.8 x 10 ⁻⁴
90	3600	4500	5850	105	200	104	245	100 75	45	34	5.5	6.5	M16	5	295	M16	17.7	1136 x 10 ⁻⁴

¹⁾ For selections see page 22 et seqq./other spiders see page 125 and following

²⁾ ØD_H + 2 mm with high speeds for expansion of spider

Review of shaft-hub-connection: Friction torques T_R [Nm] for hub type 6.0 steel

Size		Ø10	Ø11	Ø14	Ø15	Ø16	Ø19	Ø20	Ø24	Ø25	Ø28	Ø30	Ø32	Ø35	Ø38	Ø40	Ø42	Ø45	Ø48	Ø50	Ø55*	Ø60*	Ø65*	Ø70*	Ø80*	Ø90*	Ø95*	Ø100*	Ø105*
19	H7/k6	27	32	69	84	57	94	110																					
	H7/h6	15	18	57	74	38	76	94																					
24	H7/k6			70	87	56	97	114	116	133	192																		
	H7/h6			55	74	32	72	93	84	103	173																		
28	H7/k6				108	131	207	148	253	285	315	382	330	433	503														
	H7/h6				74	97	172	94	207	242	267	343	260	377	453														
38	H7/k6							208	353	395	439	531	463	603	593	689	793	776											
	H7/h6							136	290	337	373	476	367	525	491	601	721	677											
42	H7/k6								445	495	595	526	677	671	775	718	872	1043	1061										
	H7/h6								387	429	540	429	600	569	687	599	773	970	978										
48	H7/k6									616	704	899	896	1030	962	1160	1379	1222	1543										
	H7/h6									513	590			806	775	924	822	1042	1290	1073									
55	H7/k6													863	856	991	918	1119	1110	1247	1277	1665	1605	2008					
	H7/h6													750	710	863	750	976	934	1089									
65	H7/k6															1446	1355	1637	1635	1827	1887	2429	2368	2930					
	H7/h6															1275	1135	1447	1404	1619									
75	H7/k6																1710	2053	2059	2294	2384	3040	2983	3664	4293				
	H7/h6																1460	1836	1797	2056									
90	H7/k6																			3845	4249	4795	5859	5906	7036	8047	9247	9575	10845
	H7/h6																			3445									

* From Ø55 tolerance G7/m6

The friction torque is reduced with bigger fitting tolerances. For the strength calculation of shaft/hollow shaft see KTR standard 45510 on our homepage www.ktr.com.

Ordering example:	ROTEX® GS 24	98 ShA-GS	d 20	6.0 steel - Ø24		6.0 steel - Ø20	
	Coupling size	Spider hardness	Optional: Bore in spider	Hub type	Finish bore	Hub type	Finish bore

ROTEX® GS P

Backlash-free jaw couplings

Highly accurate type P according to DIN 69002



For legend of pictogram please refer to flapper on the cover

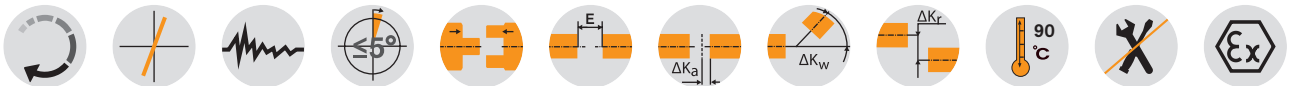

ROTEX® GS P - hubs/clamping ring material steel

Size	Spider GS ¹⁾ torque T _{KN} [Nm]		Dimensions [mm]											Clamping screws DIN EN ISO 4762				Weight per hub d _{standard} ³⁾ [kg]	Mass moment of inertia per hub with bore d _{standard} ³⁾ [kgm ²]
	98 ShA	64 ShD	d _{max}	D _H ²⁾	d _H	L	l ₁ , l ₂	l ₃	E	b	s	a	d ₃	M	z = number	T _A [Nm]	M1		
14 P	12.5	16	15	32	10.5	50	18.5	15.5	13	10	1.5	2	—	M3	4	1.89	M3	0.08	0.011 x 10 ⁻³
19 P	21	26	20	40	18	66	25	21	16	12	2	3	—	M4	6	3.05	M4	0.19	0.046 x 10 ⁻³
24 P	60	75	28	55	27	78	30	25	18	14	2	3	—	M5	4	8.5	M5	0.44	0.201 x 10 ⁻³
28 P	160	200	38	65	30	90	35	30	20	15	2.5	4	—	M5	8	8.5	M5	0.64	0.438 x 10 ⁻³
38 P	325	405	48	80	38	114	45	40	24	18	3	4	—	M6	8	14	M6	1.32	1.325 x 10 ⁻³
42 P	450	560	51	95	46	126	50	45	26	20	3	4	18.5	M8	4	35	M8	2.23	3.003 x 10 ⁻³
48 P	525	655	55	105	51	140	56	50	28	21	3.5	4	20.5	M10	4	69	M10	3.09	5.043 x 10 ⁻³
55 P	685	825	70	120	60	160	65	58	30	22	4	4.5	22.5	M10	4	69	M10	4.74	10.02 x 10 ⁻³
65 P	940	1175	70	135	68	185	75	55	35	26	4.5	4.5	30	M12	4	120	M12	6.70	191.0 x 10 ⁻⁴
75 P	1920	2400	80	160	80	210	85	63	40	30	5.0	5.0	40	M12	5	120	M12	9.90	396.8 x 10 ⁻⁴
90 P	3600	4500	105	200	104	245	100	75	45	34	5.5	6.5	50	M16	5	295	M16	17.7	1136 x 10 ⁻⁴

¹⁾ For selections see page 22 et seqq./other spiders see page 125 and following

²⁾ Ø D_H + 2 mm with high speeds for expansion of spider

For the strength calculation of shaft/hollow shaft see KTR standard 45610 on our homepage www.ktr.com.

Review of shaft-hub-connection: Friction torques T_R [Nm] for hub type 6.0 steel

Size		Ø10	Ø11	Ø14	Ø15	Ø19	Ø20	Ø24	Ø25	Ø28	Ø30	Ø32	Ø35	Ø38	Ø40	Ø42	Ø45	Ø48	Ø50	Ø55*	Ø60*	Ø65*	Ø70*	Ø80*	Ø90*	Ø95*	Ø100*	Ø105*	
14	H6/k6	11	13	29																									
	H6/h6	3	4	23																									
19	H6/k6	34	41	75	90	68	104	119																					
	H6/h6	22	26	64	80	49	85	103																					
24	H6/k6			79	95	70	110	126	134	149	201																		
	H6/h6			64	82	46	85	104	101	119	183																		
28	H6/k6				128	150	225	177	278	307	341	403	366	461	528														
	H6/h6				94	117	191	123	232	265	293	364	295	405	478														
38	H6/k6								247	386	426	475	560	511	641	644	733	828	825	970									
	H6/h6								174	323	368	408	505	415	564	542	645	757	726	897									
42	H6/k6																												
	H6/h6																												
48	H6/k6																												
	H6/h6																												
55	H6/k6																												
	H6/h6																												
65	H6/k6																												
	H6/h6																												
75	H6/k6																												
	H6/h6																												
90	H6/k6																												
	H6/h6																												

* From Ø55 tolerance G6/m6.

The friction torque is reduced with bigger fitting tolerances. For the strength calculation of shaft/hollow shaft see KTR standard 45610 on our homepage www.ktr.com.

Assignment for stub spindles according to DIN 69002

Spindle drive	ROTEX® GS P size	Dimensions according to DIN 69002														Transmittable torque T _R with d [Nm] ³⁾	Weight per hub with bore d _{standard} ³⁾ [kg]	Mass moment of inertia with bore d _{standard} ³⁾ [kgm ²]	
		Standard spindle shaft diameter d	d ₁	d ₂	d ₃	D _H	l ₁ , l ₂	L	E										
25 x 20	14 P	14	17	17	8.5	32	18.5	50	13								25	0.08	0.011 x 10 ⁻³
32k x 25	19 P37.5	16	20	19	9.5	37.5	25	66	16								60	0.16	0.037 x 10 ⁻³
32g x 30	19 P	19	23	22	9.5	40	25	66	16								71	0.19	0.046 x 10 ⁻³
40 x 35	24 P50	24	28	29	12.5	50	30	78	18								108	0.331	0.136 x 10 ⁻³
50 x 45	24 P	25	30	30	12.5	55	30	78	18								170	0.44	0.201 x 10 ⁻³
63 x 55	28 P	35	40	40	14.5	65	35	90	20								506	0.64	0.438 x 10 ⁻³
80 x 75	38 P	40	46	46	16.5	80	45	114	24								821	1.32	1.325 x 10 ⁻³

³⁾ Standard spindle shaft diameter

Ordering example:	ROTEX® GS P 24	98 ShA-GS	6.0 - Ø25				6.0 - Ø25	
	Coupling size	Spider hardness	Hub type	Finish bore	Hub type	Finish bore		

ROTEX® GS A-H

Backlash-free jaw couplings

Drop-out center design coupling

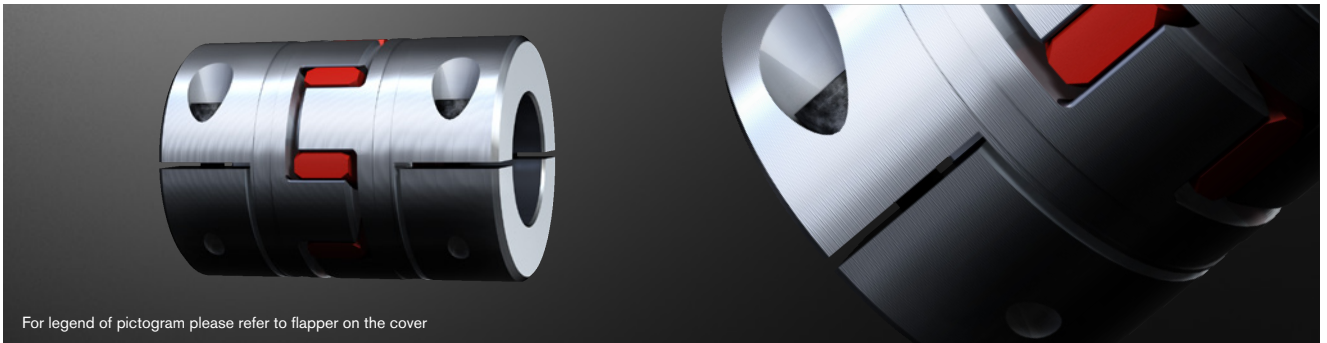

For legend of pictogram please refer to flapper on the cover

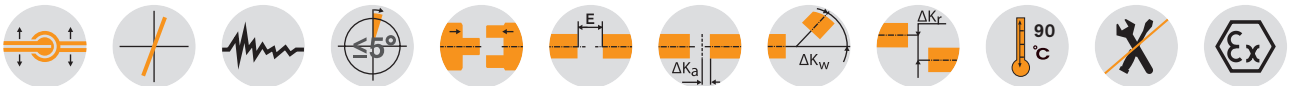

ROTEX® GS type A-H - Hub material aluminium

Size	Dimensions [mm]										Cap screws DIN EN ISO 4762	
	d _{max.}	L	l ₁ , l ₂	E	b	s	D _H	DK	x ₁ , x ₂	E ₁	M	T _A [Nm]
19	20	66	25	16	12	2.0	40	46	17.5	31	M6	10
24	28	78	30	18	14	2.0	55	57.5	22.0	34	M6	10
28	38	90	35	20	15	2.5	65	73	25.0	40	M8	25
38	45	114	45	24	18	3.0	80	83.5	33.0	48	M8	25
42	50	126	50	26	20	3.0	95	93.5	39	48	M10	49

Technical data

Size	Spider Shore-GS ¹⁾	Shore scale	Max. speed [rpm]	Torque [Nm]		Static torsion spring stiffness [Nm/rad]	Weight per hub with max. bore [kg]	Mass moment of inertia J per hub with max. bore [kgm ²]
				T _{KN}	T _{K,max}			
19	80	A	9550	6.0	12.0	618	77 x 10 ⁻³	19.6 x 10 ⁻⁶
	92	A		12.0	24.0	1090		
	98	A		21.0	42.0	1512		
	64	D		26.0	52.0	2560		
24	92	A	6950	35	70	2280	161 x 10 ⁻³	77.3 x 10 ⁻⁶
	98	A		60	120	3640		
	64	D		75	150	5030		
28	92	A	5850	95	190	4080	240 x 10 ⁻³	173 x 10 ⁻⁶
	98	A		160	320	6410		
	64	D		200	400	10260		
38	92	A	4750	190	380	6525	470 x 10 ⁻³	496 x 10 ⁻⁶
	98	A		325	650	11800		
	64	D		405	810	26300		
42	92	A	4000	265	530	10870	1770 x 10 ⁻³	2409 x 10 ⁻⁶
	98	A		450	900	21594		
	64	D		560	1120	36860		

¹⁾ For selections see page 22 et seqq./other spiders see page 125 and following

²⁾ Static torsion spring stiffness with 0.5 x T_{KN}

To make sure that the coupling can be assembled/disassembled radially, please observe the insertion dimension x1/x2 of the shafts.

Review of shaft-hub-connection: Friction torques T_R [Nm] for hub type 7.8

Size	Ø8	Ø10	Ø11	Ø14	Ø15	Ø16	Ø18	Ø19	Ø20	Ø22	Ø24	Ø25	Ø28	Ø30	Ø32	Ø35	Ø38	Ø40	Ø42	Ø45	Ø46	Ø48	Ø50
19	17	21	23	30	32	34	38	40	42														
24		21	23	30	32	34	38	40	42	47	51	53	59										
28				54	58	62	70	74	78	86	93	97	109	117	124	136	148						
38							70	74	78	86	93	97	109	117	124	136	148	156	163	175			
42										136	149	155	174	186	198	217	235	248	260	279	285	297	310

Ordering example:

ROTEX® GS 38	A-H	98 ShA-GS	7.8 - Ø38		7.9 - Ø30	
Coupling size	Type	Spider hardness	Hub type	Finish bore	Hub type	Finish bore

Type A-H

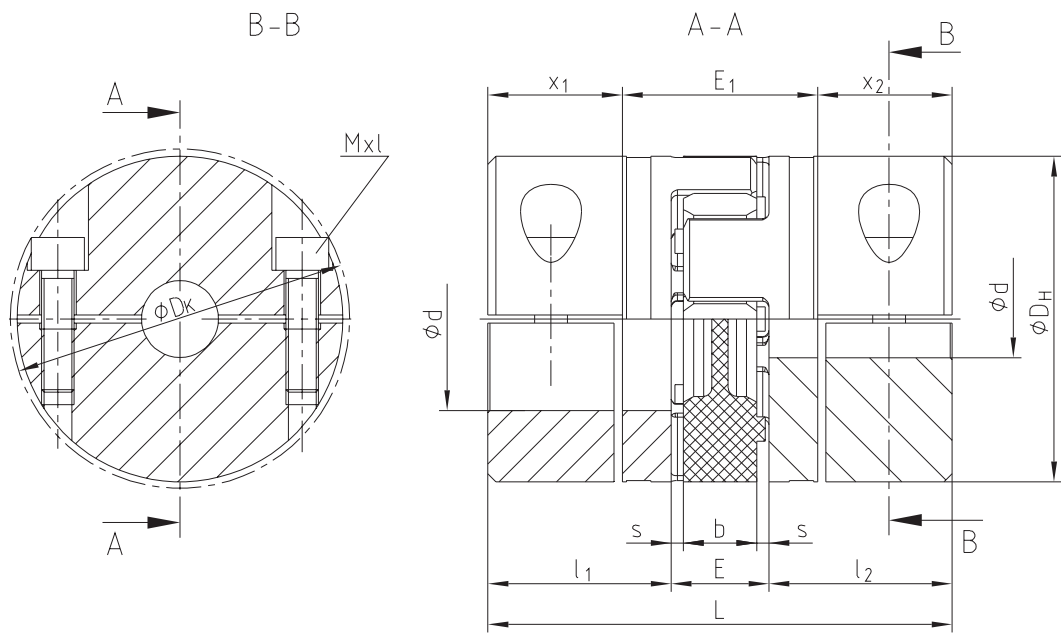

Caution:
Feather keyways are offset to each other by approx. 5°!
Hub material: Al-H

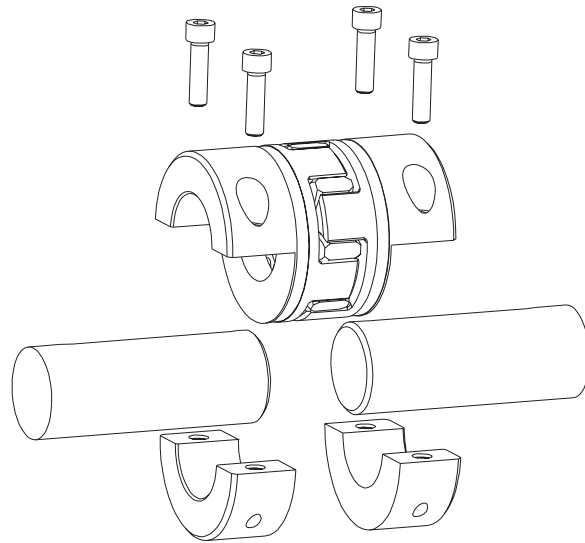

Types of hubs

Type 7.8

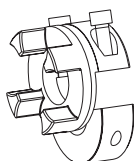

clamping hub type H without feather keyway for single-cardanic connection

Type 7.9

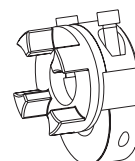

clamping hub type H with feather keyway for single-cardanic connection

ROTEX® GS ZR3

Backlash-free intermediate shaft couplings

Intermediate shaft coupling with aluminium pipe bonded

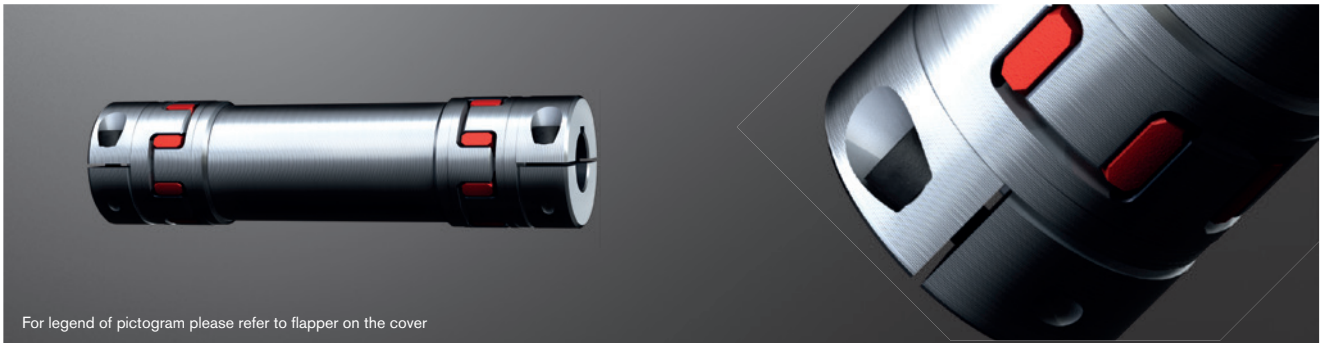

For legend of pictogram please refer to flapper on the cover



ROTEX® GS Type ZR3 - Hub material aluminium/intermediate pipe material aluminium

Size	Dimensions [mm]														Cap screws DIN EN ISO 4762	
	d _{max.}	D _H	l ₁	L	l ₃	E	L _R		L _{ZR} = L _R + 2 · l ₃		d _R	DK	t ₁	e	M	T _A [Nm]
							Min.	Max.	Min.	Max.						
14	15	30	18.5	36.0	14.5	13	72	2971	101	3000	28	33.3	7.5	10.5	M4	2.9
19	20	40	25	49.0	17.5	16	98	2965	133	3000	40	46	8.0	14.5	M6	10
24	28	55	30	59.0	22.0	18	121	3456	165	3500	50	57.5	10.5	20	M6	10
28	38	65	35	67.0	25.0	20	137	3950	187	4000	60	73	11.5	25	M8	25
38	45	80	45	83.5	33.0	24	169	3934	235	4000	70	83.5	15.5	30	M8	25
42	50	95	50	93.0	36.5	26	180	3927	253	4000	80	93.5	18.0	32	M10	49
48	55	105	56	100.0	39.5	28	202	3921	281	4000	100	105	18.5	36	M12	86

Technical data of type ZR3

Size	Spider GS ¹⁾ torque T _{KN} [Nm]		Moment of inertia [10 ⁻³ kgm ²]			Static torsion spring stiffness [Nm/rad]
	98 ShA	64 ShD	Hub ²⁾		Pipe/meter	
14	12.5	16.0	0.00362	0.00238	0.088	858
19	21.0	26.0	0.02002	0.01304	0.329	3243.6
24	60.0	75.0	0.07625	0.04481	0.673	6631.8
28	160	200	0.17629	0.10950	1.199	11814.1
38	325	405	0.50385	0.2572	2.972	29290.4
42	450	560	1.12166	0.5523	4.560	44929.7
48	525	655	1.87044	1.1834	9.251	91158.2

¹⁾ For selections see page 22 et seqq./other spiders see page 125 and following

²⁾ With d_{max.}

³⁾ Torsion spring stiffness with a length of 1 m of intermediate pipe with L_{pipe} = L_{ZR} - 2 · L

For inquiries and orders please specify the shaft distance dimension L_R along with the maximum speed to review the critical bending speed. See diagramme on page 129.

The intermediate pipe can be combined with other hub types, but in that case it can no longer be disassembled radially. Please specify the shaft distance dimension required in your order.

With vertical application a support washer has to be used (please specify in your order).

Insertion dimension of shaft l₃, to make sure that the coupling can be assembled/disassembled radially.

Straightness/concentricity of pipes according to DIN EN 755-1.

Review of shaft-hub-connection: Friction torques T_R [Nm] for hub type 7.5

Size	Ø6	Ø8	Ø10	Ø11	Ø14	Ø15	Ø16	Ø18	Ø19	Ø20	Ø22	Ø24	Ø25	Ø28	Ø30	Ø32	Ø35	Ø38	Ø40	Ø42	Ø45	Ø46	Ø48	Ø50	Ø55
14	5.5	7.4	9.2	10.1	12.9	13.8																			
19		17	21	23	30	32	34	38	40	42															
24			21	23	30	32	34	38	40	42	47	51	53	59											
28					54	58	62	70	74	78	86	93	97	109	117	124	136	148							
38								70	74	78	86	93	97	109	117	124	136	148	156	163	175				
42											136	149	155	174	186	198	217	235	248	260	279	285	297	310	
48											199	217	226	253	271	290	317	344	362	380	407	416	434	452	498

Ordering
example:

ROTEX® GS 24	ZR3	1200 mm	98 ShA-GS	7.5 - Ø24	7.5 - Ø24
Coupling size	Type	Shaft distance dimension (L _R)	Spider hardness	Hub type	Finish bore

Morskate®



Any questions? Please contact us.

Morskate Aandrijvingen BV

Oosterveldsingel 47A
7558 PJ Hengelo (Ov)
The Netherlands

NL
T +31 (0)74 - 760 11 11
info@morskateaandrijvingen.nl
www.morskateaandrijvingen.nl

DE
T +49 692 - 222 34 95
info@morskateantriebstechnik.de
www.morskateantriebstechnik.de

EN
T +31 (0)74 - 760 11 11
info@morskatedrivetechnology.com
www.morskatedrivetechnology.com