

Slat Top Plastic Chain

Series **uni 255 FT** Type **Magnetic**

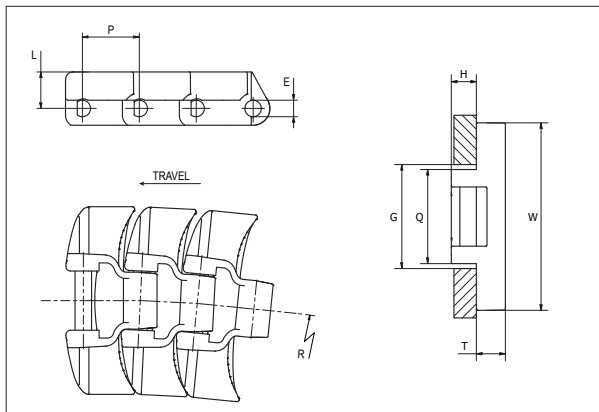
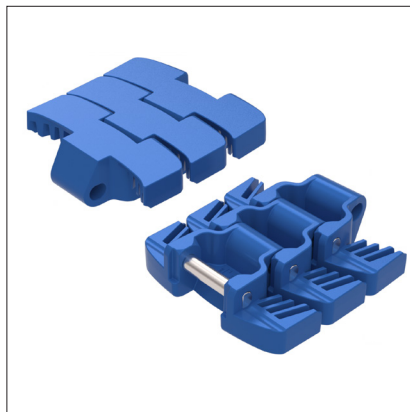

Slat Top Plastic Chain
 Side flexing chain
 Pitch: 25.4 mm (1.00 in)
 Backflex radius:
 200 mm (7.87 in)
 Permissible tensile strength:
 All POM materials: 1800 N
 (405 lbf)
 Standard shipping lengths:
 boxes of 120 links
 = 3.048 m (10.0 ft)

E		G		H		L		P		Q		T	
mm	in	mm	in	mm	in	mm	in	mm	in	mm	in	mm	in
7.1	0.28	44.0	1.73	11.0	0.43	16.2	0.64	25.4	1.00	42.0	1.65	12.7	0.5

All dimensions are for chains in POM material.

	Width (W)		Material & color	Pin material	Weight		Min. radius (R)	
	mm	in			kg/m	lb/ft	mm	in
K330	83.8	3.30	POM-D B G POM-DK DG	SS431	1.76	1.18	500	19.69
K450	114.3	4.50	POM-D B G	SS431	2.10	1.41	500	19.69

Non standard material and color: See uni Material and Color Overview.
 Non standard pin material: See uni Material and Color Overview.

STANDARD

SIDE FLEXING

PITCH 25.4 MM/1.00 IN

Sprocket

No. of teeth	Metric bore				Imperial bore		Overall diameter		Pitch diameter		Hub diameter		Dimension A		Dimension B		Machined solid sprocket PA6	Machined solid Idler PA6	
	in	0.32	0.98	1.18	1.57	1.00													1.50
	mm	Pilot-Bore	25.0	30.0	40.0	25.4	38.1	mm	in	mm	in	mm	in	mm	in				
Z16								132.1	5.20	130.2	5.13	110.0	4.33	67.5	2.66	81.9	3.22		
Z18								148.5	5.85	146.3	5.76	126.0	4.96	75.7	2.98	89.9	3.54		
Z21								179.9	7.08	170.4	6.71	150.0	5.91	88.0	3.46	101.9	4.01		
Z31								254.2	10.01	251.1	9.89	230.0	9.06	128.6	5.06	142.1	5.59		

Machined solid sprocket Machined square bore

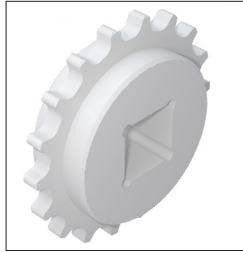
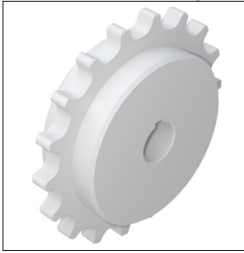

Non standard material and color:
See uni Material and Color Overview.
Width of tooth: 11.0 mm (0.43 in)
Width of sprocket: 30.0 mm (1.18 in)

Two-part sprocket

No. of teeth					Overall diameter		Pitch diameter		Hub diameter		Dimension A		Dimension B		Machined split sprocket PA6	Machined split Idler PA6
	in	0.32	0.98	1.57												
	mm	Pilot-Bore	25.0	40.0	mm	in	mm	in	mm	in	mm	in				
Z16					132.1	5.20	130.2	5.13	110.0	4.33	67.5	2.66	81.9	3.22		
Z18					148.5	5.85	146.3	5.76	126.0	4.96	75.7	2.98	89.9	3.54		
Z21					179.9	7.08	170.4	6.71	150.0	5.91	88.0	3.46	101.9	4.01		
Z31					254.2	10.01	251.1	9.89	230.0	9.06	128.6	5.06	142.1	5.59		

Machined two-part sprocket

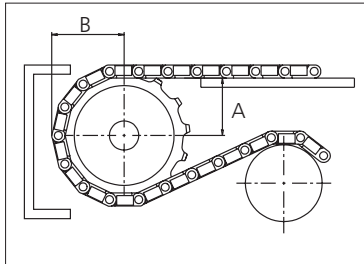
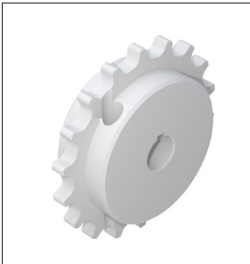

Please ensure that sufficient size shaft and keyway are chosen for corresponding load.

Non standard material and color:
See uni Material and Color Overview.

Other sprocket sizes are available upon request
Width of tooth: 11.0 mm (0.43 in)
Width of sprocket: 30.0 mm (1.18)
uni Retainer Rings: See uni Retainer Ring data sheet
uni Idler: See uni Idler data sheet